

LIQUID

LC

CONTROLS®



DEF

Diesel Exhaust Fluid Flowmeter Systems



Архангельск (8182)63-90-72
Астана (7172)727-132
Астрахань (8512)99-46-04
Барнаул (3852)73-04-60
Белгород (4722)40-23-64
Брянск (4832)59-03-52
Владивосток (423)249-28-31
Волгоград (844)278-03-48
Вологда (8172)26-41-59
Воронеж (473)204-51-73
Екатеринбург (343)384-55-89
Иваново (4932)77-34-06
Ижевск (3412)26-03-58
Казань (843)206-01-48

Калининград (4012)72-03-81
Калуга (4842)92-23-67
Кемерово (3842)65-04-62
Киров (8332)68-02-04
Краснодар (861)203-40-90
Красноярск (391)204-63-61
Курск (4712)77-13-04
Липецк (4742)52-20-81
Магнитогорск (3519)55-03-13
Москва (495)268-04-70
Мурманск (8152)59-64-93
Набережные Челны (8552)20-53-41
Нижний Новгород (831)429-08-12
Новокузнецк (3843)20-46-81

Новосибирск (383)227-86-73
Омск (3812)21-46-40
Орел (4862)44-53-42
Оренбург (3532)37-68-04
Пенза (8412)22-31-16
Пермь (342)205-81-47
Ростов-на-Дону (863)308-18-15
Рязань (4912)46-61-64
Самара (846)206-03-16
Санкт-Петербург (812)309-46-40
Саратов (845)249-38-78
Севастополь (8692)22-31-93
Симферополь (3652)67-13-56
Смоленск (4812)29-41-54

Сочи (862)225-72-31
Ставрополь (8652)20-65-13
Сургут (3462)77-98-35
Тверь (4822)63-31-35
Томск (3822)98-41-53
Тула (4872)74-02-29
Тюмень (3452)66-21-18
Ульяновск (8422)24-23-59
Уфа (347)229-48-12
Хабаровск (4212)92-98-04
Челябинск (351)202-03-61
Череповец (8202)49-02-64
Ярославль (4852)69-52-93

Единый адрес для всех регионов: crm@nt-rt.ru || www.lcmeter.nt-rt.ru

DEF Technology Engineered for Results

DEF Custody Transfer Done Right

Understanding that Diesel Exhaust Fluid (DEF) is a sensitive liquid and tricky to handle, Liquid Controls (LC) Engineers designed and developed a line of DEF Flowmeter Systems that can accommodate this unique solution of deionized water and urea, all while delivering the accuracy and durability during custody transfers LC is recognized for.



In 2010 the United States Environment Protection Agency (EPA) set an initiative that required engine manufacturers to adhere stringent Diesel Emission standards. These regulations were set forth to radically decrease the emission particulate matter (PM) that was produced from diesel engine systems such as soot, ash and nitrogen oxide emissions.



Crystallized urea: the result of DEF being exposed to air, causing "salt out."



With a turndown ratio of 20:1, the LC DEF PD Meter is engineered for consistent accuracy through routine starts and stops.

Designed for Success

Although DEF is non-toxic, it can quickly corrode many common materials and metals such as aluminum, iron, steel, and brass. LC DEF Positive Displacement Flowmeter Systems are specifically built with a 316 stainless steel housing (33% lighter than similar DEF systems in the marketplace today), advanced (patent pending) polymer components within, and EPDM seals that resist breakdown from DEF.

Turbine DEF Flowmeter Systems, ideal for high flow rate applications, are also manufactured with 316 stainless steel housings, duplex stainless steel rotors, and engineered polymer sleeve bearings.

Air Entry Prevention

Another major issue LC engineers considered when designing the DEF Flowmeter System is the reality that with prolonged exposure to air, the deionized water evaporates and the urea solution is left behind to 'salt out' and crystallize. Salted-out urea crystals can block the flow of product through a delivery system and therefore the system must remain completely full of DEF to avoid this threat. LC DEF Flowmeter Systems are recommended with slip-on weld flanges and Run-Dry Sensor protection. Slip-on weld flanges produce a hydro-fit seal that prevents air exposure compared to threaded connections, which are susceptible to DEF weeping. The Air Entry Prevention System recognizes the hazard of air well before it is introduced into the system, and will stop the flow of product if air is detected.



Cross slice of the internal rotor components of a DEF PD Meter. Never install meter with an inlet and outlet mounted vertically.

Selecting the Right DEF Flowmeter System

Positive Displacement or Turbine Flowmeter System

Typically, positive displacement systems are the right choice for applications where vibrations and frequent start-stops are common. Because they do not require a straight run of pipe on the outlet and inlet side of the flowmeter, positive displacement systems have a small footprint.

Turbine systems carry a low initial investment, and are ideal for high flow-rate applications. They are available

in 1/2" to 4" sizes, providing flow rates up to 1,200 GPM. Turbine systems are a good choice where vibrations and frequent start-stops aren't a concern. The initial investment of turbine systems is low, but since a straight run of pipe upstream and downstream of the meter is required on the outlet and inlet side of the flowmeter, the footprint of turbine systems is larger than positive displacement systems.



DEF Custody Transfer Application Photo Courtesy of Tecalemit Inc.

Preconfigured or Custom Flowmeter Systems

Liquid Controls offers three preconfigured PD and Turbine flowmeter systems. These six systems are ideal for most DEF metering applications. If the preconfigured systems do not suit your specific needs, custom DEF flowmeter systems can be constructed per request. Your local LC distributor can help you specify a custom system that fits perfectly into your application.

	Positive Displacement Flowmeter Systems	Turbine Flowmeter Systems
DEF-Compatible Components	✓	✓
Electronic Register Available	✓	✓
Mechanical Registration	✓	
Air Eliminator Available	✓	✓
Weld Flanges Available	✓	✓
U.S. Weights & Measures Approved	✓	✓
Complete Metering Solution	✓	✓
Low Lifetime Cost of Ownership	✓	✓
Low Initial Investment		✓
Small Footprint	✓	
Flexible Mounting Configurations	✓	
Low Flow Rate Accuracy	✓	✓
1,200 GPM Flow Rate Available		✓
Low Pressure Drop	✓	✓
Start/Stop Applications	✓	

Unstoppable by Design

To simulate three years of continuous use and accuracy, our engineers tested the DEF Positive Displacement Flowmeter System at full-rated speed in our calibrated test labs to push it to its limit.

Production DEF meters are rigorously evaluated on an automated fluid flow test line to ensure they exceed the standards established for accuracy and repeatability.

The LC DEF PD Meter was stopped and started over 10,000 times, driving over 800,000 gallons through a 316 Stainless Steel housing and patent-pending engineered polymer rotor assembly.

After this extensive quality testing, the LC DEF PD Flowmeter remained within regulatory U.S. Weights & Measures (NTEP) standards and continued to deliver legendary Liquid Controls accuracy and repeatability.

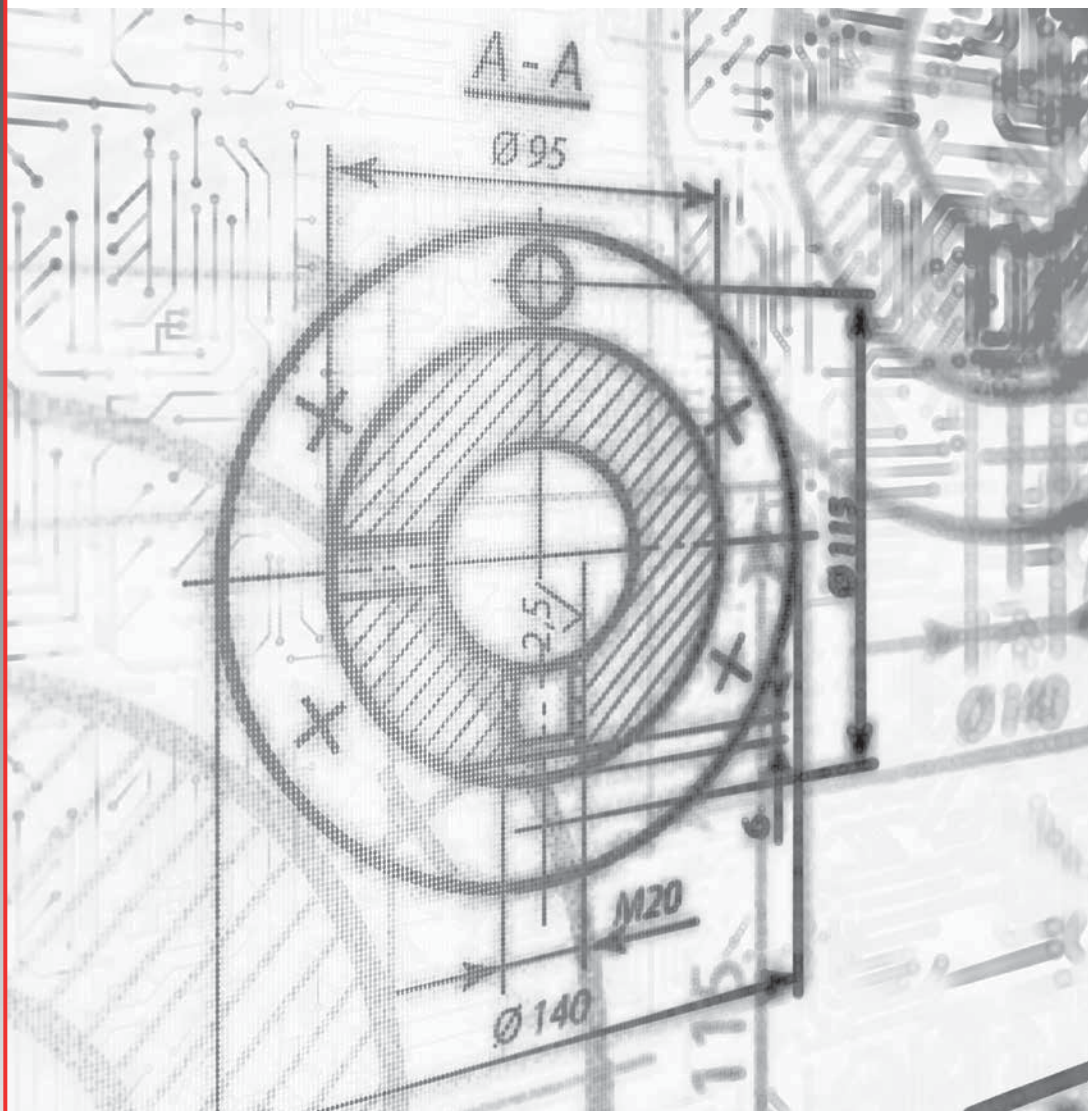

Positive Displacement DEF Flowmeter Systems

Select Specifications

Repeatability

Capable of 0.02% or better at any flow rate over entire range

Temperature Range

12 to 100° F (-11 to 37° C)

DEF freezes at 12° F; recommended DEF storage is below 86° F

Flow Range

5 to 100 GPM

Maximum Working Pressure

150 PSI (10.5 bar)

Regulatory

United States Weights & Measures

Materials of Construction

316 Stainless Steel, DEF-compatible engineered polymer,* 420 Stainless Steel, EPDM Seals

Liquid Controls' M-7 Class 18 Flowmeters are Specifically Engineered to Meter DEF

Their patent-pending design features rotors made out of an advanced polymer that is chemically resistant to DEF's caustic properties and machined to meter DEF's distinct physical properties with high accuracy. The new design allows the M-7 Class 18 to meet U.S. Weights & Measures (NTEP) accuracy approvals across an impressive flow range, and it is approved at a minimum of 5 GPM up to a maximum of 100 GPM (a 20:1 turndown ratio). The M-7 Class 18 Flowmeter can be mounted in a variety of different configurations, and it is built to meter with high accuracy in stationary applications such as DEF carts, bulk plants, and terminals, as well as high-vibration mobile applications such as delivery trucks.

Features

- Wide Flow Range (5 to 100 GPM)
- U.S. Weights & Measures Approved (NTEP)
- No Rotating Contact Inside the Measuring Chamber
- Lightweight Design Constructed with DEF-Compatible 316 Stainless Steel and Advanced Polymer Materials
- Low Pressure Drop
- No Axial Thrust on Bearings
- Sustained Accuracy
- Low Lifetime Cost of Ownership
- Low Maintenance
- Flexible Mounting Configurations



DEF Positive Displacement Flowmeter System



DEF Reservoir

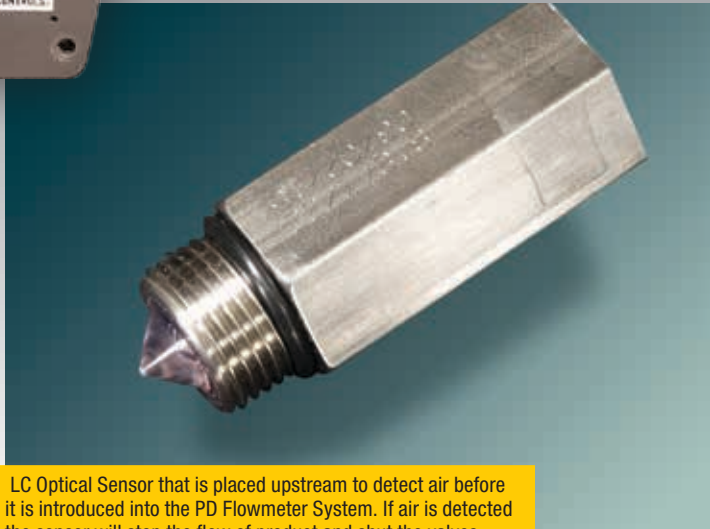

LC Optical Sensor that is placed upstream to detect air before it is introduced into the PD Flowmeter System. If air is detected the sensor will stop the flow of product and shut the valves.

Preconfigured DEF PD Flowmeter Systems

The Superior DEF Custody Transfer Experience Recommended by LC Engineers Specifically for DEF

Electronic Air Entry Prevention System

An electronic system best prevents exposing DEF to air and risking damage incurred by salting out. This system includes an optical sensor positioned near the bottom of the DEF tank that detects air exposure and will force the valve shut prior to the air entering the system.

- M-7 Class 18 Positive Displacement Flowmeter
- LectroCount LCR-II Electronic Register
- Banjo® Motorized Ball Valve with EPDM Seals
- Mesh Basket Strainer
- Electronic Optical Air Sensor

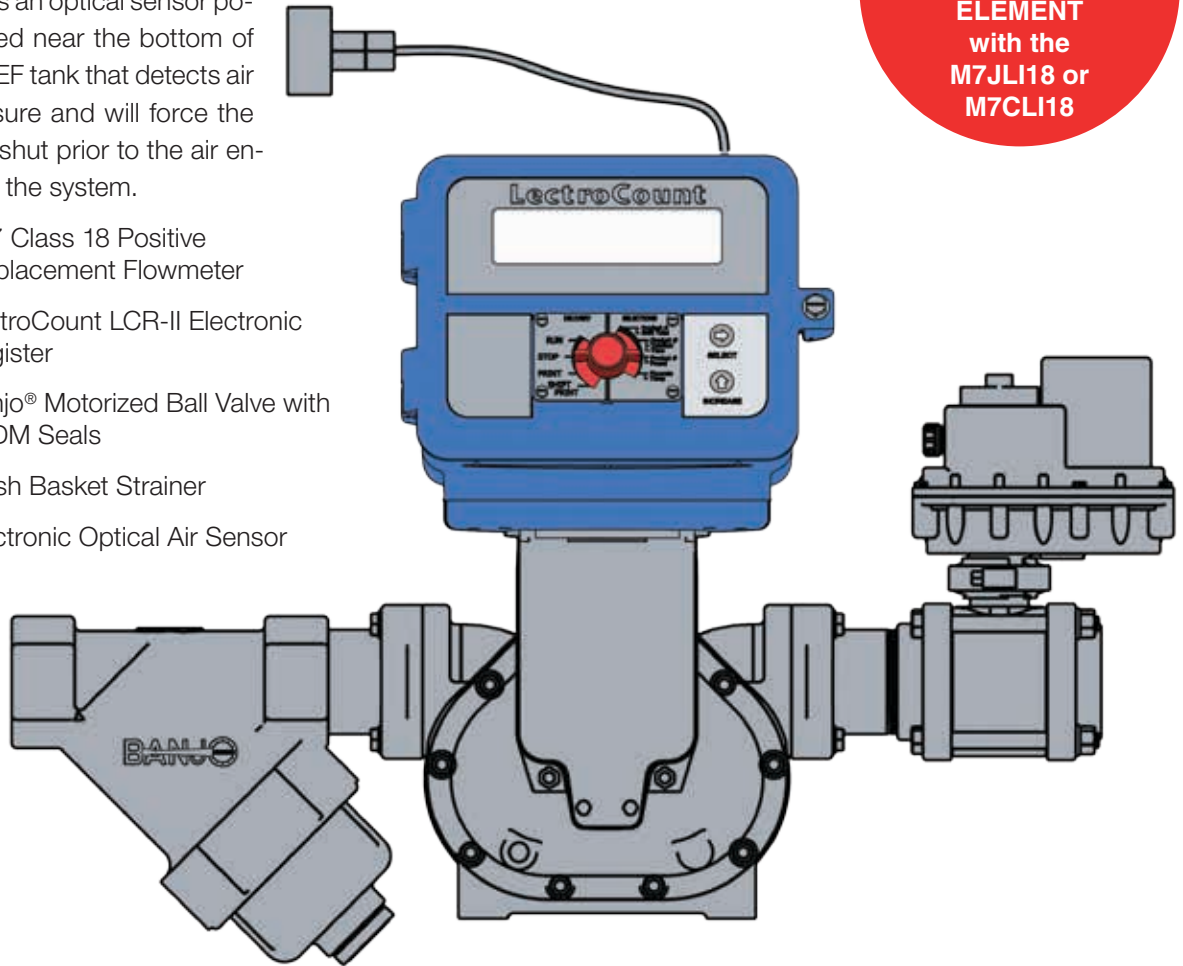

**THREE YEAR
EXTENDED
WARRANTY
ON METER
ELEMENT
with the
M7JLI18 or
M7CLI18**

	Standard Registration	Electronic Air Entry Prevention	Basket Strainer**	Mechanical Air Elimination	Downstream Ball Valve***	Printer
M7JLI18	LCR-II	YES	YES	NO	YES	NO
M7MLI18	LCR-II	YES	YES	NO	YES	YES
M7CLI18	LCR-II	NO	YES	YES	NO	NO
M7C18	MECHANICAL	NO	YES	YES	NO	NO
M7A18	MECHANICAL	NO	NO	NO	NO	NO

** Electronic registration available.

*** Electronic air entry prevention and equipped with banjo polypropylene "Y" strainer.

*** In most installations, the ball valve will be controlled by a relay that is controlled by the register. That relay will be powered independently of the register.

Mechanical Air Elimination System with Electronic Registration

This mechanical-pneumatic system with a LCR-II electronic register eliminates air using a mechanical air eliminator downstream valve activated by register and powered by air.

- M-7 Class 18 Positive Displacement Flowmeter
- LectroCount LCR-II Electronic Register
- Mechanical Air Eliminator
- Mesh Basket Strainer
- Stainless Pneumatically Actuated V7 Valve

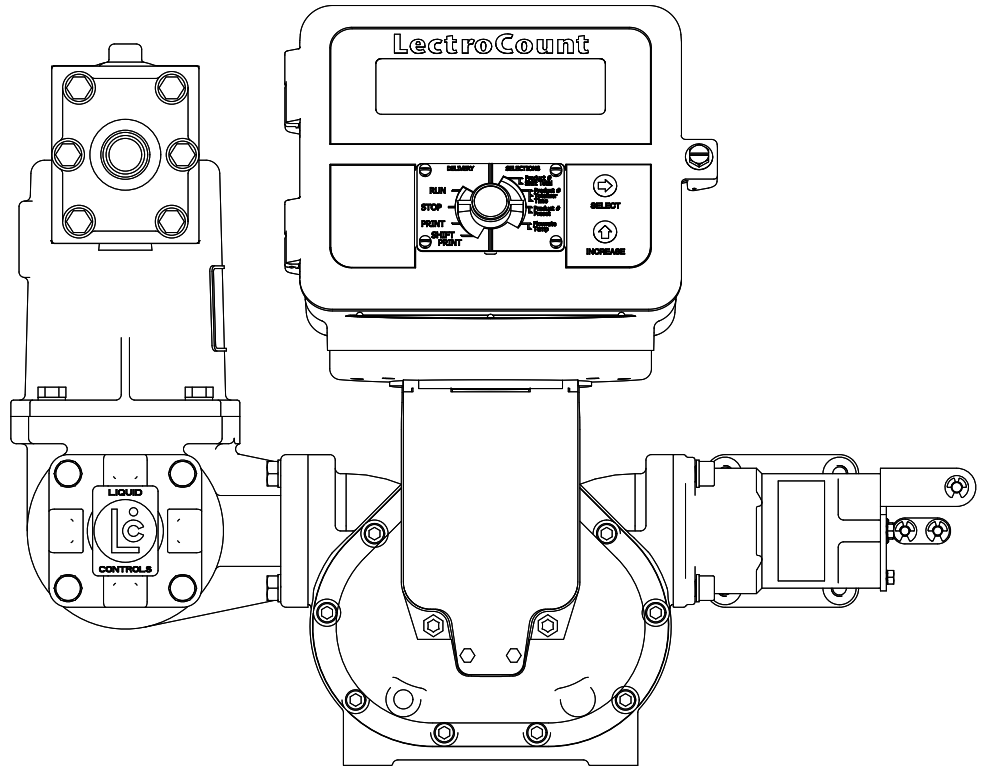

Basic Electronic System

A basic DEF system with a LCR-II electronic register.

- M-7 Class 18 Positive Displacement Flowmeter
- LectroCount LCR-II Electronic Register

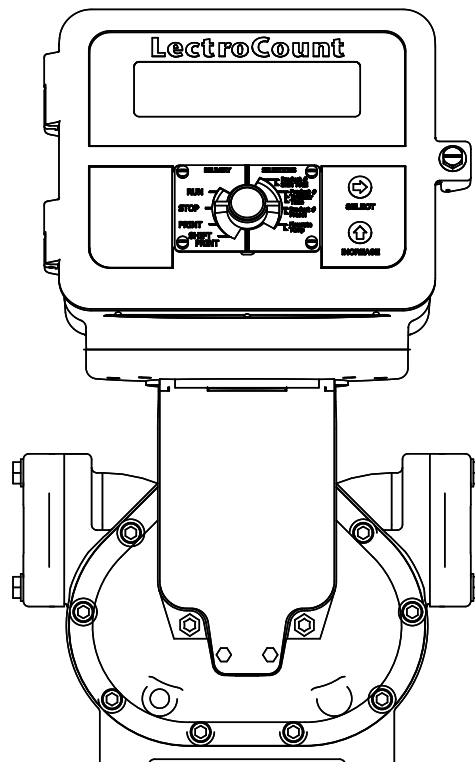



Mastering DEF Metering for a Growing Market

Liquid Controls DEF Flowmeter Systems are poised to become the standard mode of DEF measurement as the market demand increases across the globe. In light of new regulatory EPA laws regarding diesel emissions, LC engineers studied the complex chemistry of DEF and developed a line of Flowmeter Systems specifically engineered to meet the challenges of DEF custody transfers that are both cost-effective and deliver the accuracy Liquid Controls is recognized for.

With ever-changing regulatory and compliance statutes, and customer challenges, LC has driven for excellence by focusing on continuous ingenuity. By improving the reliability of LC Flow Meter Technology Systems, as well as designing new systems, LC has been able to meet customers' needs and expectations for controlling and measuring high-value liquids and gases.

Setting The Standard

For over 60 years Liquid Controls has been the leader in pioneering meter and register technology across the globe. LC has engineered, designed, and produced world-class Flowmeter Systems with minimal moving parts and no rotating contact inside the measuring chamber. That means sustained accuracy in the measurement of everything from acetate to asphalt and petroleum to peanut butter.

По вопросам продажи и поддержки обращайтесь:

Архангельск (8182)63-90-72
Астана (7172)727-132
Астрахань (8512)99-46-04
Барнаул (3852)73-04-60
Белгород (4722)40-23-64
Брянск (4832)59-03-52
Владивосток (423)249-28-31
Волгоград (844)278-03-48
Вологда (8172)26-41-59
Воронеж (473)204-51-73
Екатеринбург (343)384-55-89
Иваново (4932)77-34-06
Ижевск (3412)26-03-58
Казань (843)206-01-48

Калининград (4012)72-03-81
Калуга (4842)92-23-67
Кемерово (3842)65-04-62
Киров (8332)68-02-04
Краснодар (861)203-40-90
Красноярск (391)204-63-61
Курск (4712)77-13-04
Липецк (4742)52-20-81
Магнитогорск (3519)55-03-13
Москва (495)268-04-70
Мурманск (8152)59-64-93
Набережные Челны (8552)20-53-41
Нижний Новгород (831)429-08-12
Новокузнецк (3843)20-46-81

Новосибирск (383)227-86-73
Омск (3812)21-46-40
Орел (4862)44-53-42
Оренбург (3532)37-68-04
Пенза (8412)22-31-16
Пермь (342)205-81-47
Ростов-на-Дону (863)308-18-15
Рязань (4912)46-61-64
Самара (846)206-03-16
Санкт-Петербург (812)309-46-40
Саратов (845)249-38-78
Севастополь (8692)22-31-93
Симферополь (3652)67-13-56
Смоленск (4812)29-41-54

Сочи (862)225-72-31
Ставрополь (8652)20-65-13
Сургут (3462)77-98-35
Тверь (4822)63-31-35
Томск (3822)98-41-53
Тула (4872)74-02-29
Тюмень (3452)66-21-18
Ульяновск (8422)24-23-59
Уфа (347)229-48-12
Хабаровск (4212)92-98-04
Челябинск (351)202-03-61
Череповец (8202)49-02-64
Ярославль (4852)69-52-93