

# LCMASS 100

CORIOLIS MASS FLOW METER SYSTEMS



Архангельск (8182)63-90-72  
Астана (7172)727-132  
Астрахань (8512)99-46-04  
Барнаул (3852)73-04-60  
Белгород (4722)40-23-64  
Брянск (4832)59-03-52  
Владивосток (423)249-28-31  
Волгоград (844)278-03-48  
Вологда (8172)26-41-59  
Воронеж (473)204-51-73  
Екатеринбург (343)384-55-89  
Иваново (4932)77-34-06  
Ижевск (3412)26-03-58  
Казань (843)206-01-48

Калининград (4012)72-03-81  
Калуга (4842)92-23-67  
Кемерово (3842)65-04-62  
Киров (8332)68-02-04  
Краснодар (861)203-40-90  
Красноярск (391)204-63-61  
Курск (4712)77-13-04  
Липецк (4742)52-20-81  
Магнитогорск (3519)55-03-13  
Москва (495)268-04-70  
Мурманск (8152)59-64-93  
Набережные Челны (8552)20-53-41  
Нижний Новгород (831)429-08-12  
Новокузнецк (3843)20-46-81

Новосибирск (383)227-86-73  
Омск (3812)21-46-40  
Орел (4862)44-53-42  
Оренбург (3532)37-68-04  
Пенза (8412)22-31-16  
Пермь (342)205-81-47  
Ростов-на-Дону (863)308-18-15  
Рязань (4912)46-61-64  
Самара (846)206-03-16  
Санкт-Петербург (812)309-46-40  
Саратов (845)249-38-78  
Севастополь (8692)22-31-93  
Симферополь (3652)67-13-56  
Смоленск (4812)29-41-54

Сочи (862)225-72-31  
Ставрополь (8652)20-65-13  
Сургут (3462)77-98-35  
Тверь (4822)63-31-35  
Томск (3822)98-41-53  
Тула (4872)74-02-29  
Тюмень (3452)66-21-18  
Ульяновск (8422)24-23-59  
Уфа (347)229-48-12  
Хабаровск (4212)92-98-04  
Челябинск (351)202-03-61  
Череповец (8202)49-02-64  
Ярославль (4852)69-52-93

Единый адрес для всех регионов: [crn@nt-rt.ru](mailto:crn@nt-rt.ru) || [www.lcmeter.nt-rt.ru](http://www.lcmeter.nt-rt.ru)

# **LCMass<sup>®</sup> 100-140 Series**

## **Mass Flow Sensor**

## Technical Data Sheet

- **HIGH ACCURACY**  
The LCMass 100 achieves a  $\pm 0.15\%$  accuracy on liquids.
- **COMPACT ECONOMIC DESIGN**  
Straight twin-tube design allows for an overall smaller installation envelope, is lighter weight, and offers a more economic device.
- **LOW PRESSURE DROP**  
Innovative flow splitter and straight tube design assure minimal pressure drop and high flow rates.
- **RIGID OUTER HOUSING**  
Secondary containment ensures protection against leaks and helps isolate the measuring tubes from external vibration.
- **ENTRAINED GAS MANAGEMENT**  
State-of-the-art software monitors and manages entrained gas. This means the meter can send a alert when there is entrained gas present, all while measuring the liquid but not the gas.



**LIQUID CONTROLS<sup>®</sup>**

*An IDEX Energy & Fuels Business*

## **PUBLICATION UPDATES AND TRANSLATIONS**

---

The most current English versions of all Liquid. It is the responsibility of the local distributor to provide the most current version of LC manuals, instructions, and specification sheets in the required language of the country, or the language of the end user to which the products are shipping. If there are questions about the language of any LC manuals, instructions, or specification sheets, please contact your local distributor.

The documentation is only complete when used in combination with the relevant documentation for the signal converter.

All rights reserved. It is prohibited to reproduce this documentation, or any part thereof, without the prior written authorization of Liquid Controls, LLC.

Content is subject to change without notice.

The documentation is only complete when used in combination with the relevant documentation for the signal converter.

# TABLE OF CONTENTS

---

---

## 1. PRODUCT FEATURES

---

1.1 Overview.....4  
1.2 Features and Options.....5  
1.3 Meter / Converter Combinations.....6  
1.4 Measuring Principle (Twin Tube).....7

---

## 2. TECHNICAL DATA

---

2.1 Technical Data .....8  
2.3 Maximum Pipework Forces  
    (End Loadings) .....11  
2.4 Measuring Accuracy .....12  
2.5 Guidelines for Maximum  
    Operating Pressure .....13  
2.6 Dimensions and Weights .....15

---

## 3. INSTALLATION

---

3.1 Intended Use .....22

# 1. PRODUCT FEATURES

## 1.1 Overview

The LCMass 140 is the cost effective solution for accurate measurement for a variety of applications. The LCMass 140 reliably measures massflow, density,

volume, temperature, volume concentration, or solid content.



1. Modular electronics with a range of output options (see separate documentation for details).
2. The power of the MFC 400 gives comprehensive diagnostics together with Entrained Gas Management (EGM).
3. Available with a range of flange and hygienic connections.

1. Remote terminal box

### Highlights

- Innovative twin measuring tubes.
- Easily drained and easy to clean
- Resistant to installation and process effects. Long working life.
- Optimized flow divider for minimum pressure loss.
- High levels of accuracy mean an excellent price / performance ratio.
- Modular electronics with data redundancy - easy replacement of electronics.

### Industries

- Water and Wastewater
- Chemical
- Food and Beverage
- Paper and Pulp
- Petrochemical industry
- Pharmaceutical industry

### Applications

- Suitable for all standard applications up to 266°F / 130°C.
- Hygienic connections make it ideal for food / beverage applications.

# 1. PRODUCT FEATURES

## 1.2 Features and Options

### Features

- Available as compact or remote.
- Low pressure loss guarantees a low pressure drop across the meter.
- Self draining.
- Easy to clean.



### Connection Options

- A range of flanges up to ASME Class 600.
- Supports a wide range of industry-standard hygienic connections.
- Adaptable to suit customer's hygienic connections.

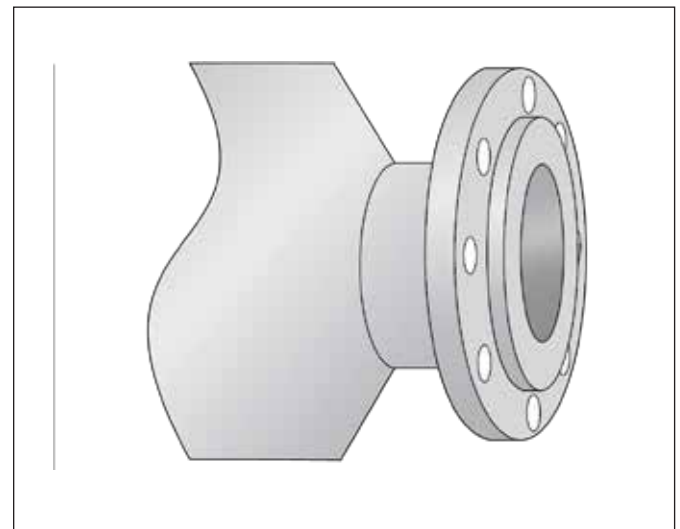

### Heating Jacket and Purge Port

- Heating jacket option for use with temperature dependent products.
- Prevents solidification of process product.
- Purge port option for protection in the event of measuring tube failure.
- Allows hazardous chemicals to be drained away safely.
- Can also be used for the early detection of measuring tube failure where highly toxic chemicals are being measured.

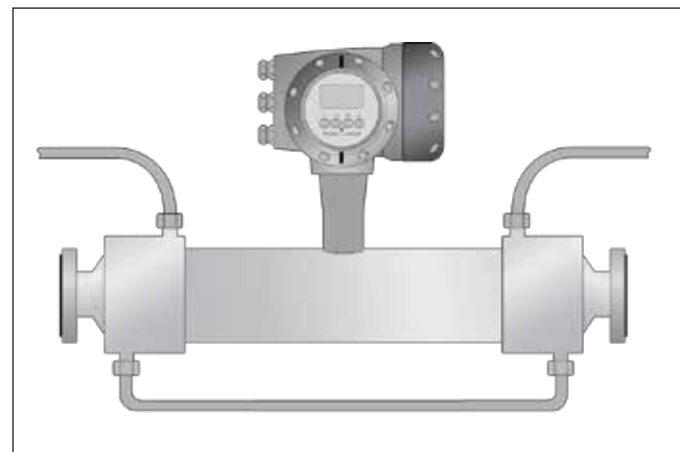

# 1. PRODUCT FEATURES

## 1.3 Meter / Converter Combinations

Converter	LC140	
Configuration	Compact	Remote field
LCMass 100	140C	140F

## 1.4 Measuring Principle (Twin Tube)

### Static Meter Not Energized and With No Flow

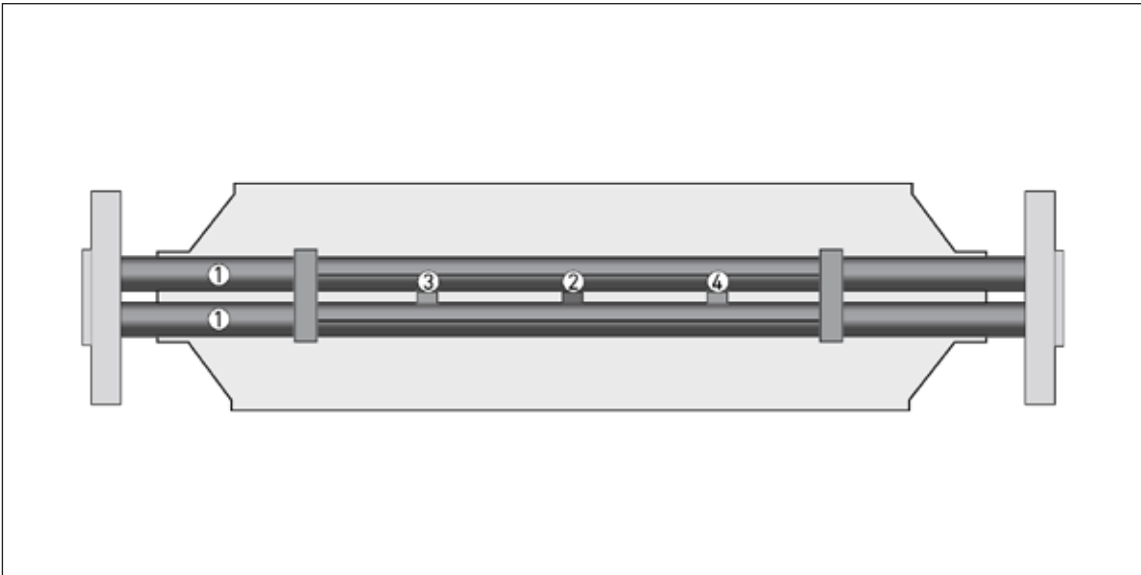

1. Measuring tubes
2. Drive coil
3. Sensor 1
4. Sensor 2

A Coriolis twin tube mass flowmeter consists of two measuring tubes 1, a drive coil 2, and two sensors 3 - 4) that are positioned on either side of the drive coil.

# 1. PRODUCT FEATURES

## 1.4 Measuring Principle (Twin Tube)

### Energized Meter

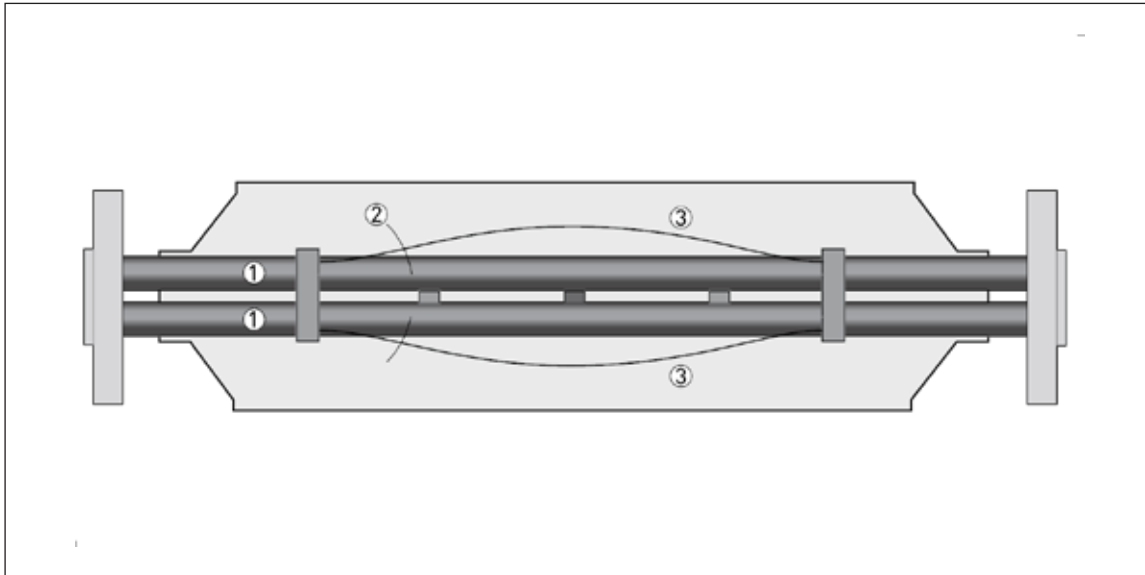

1. Measuring tubes
2. Direction of oscillation
3. Sine wave

When the meter is energized, the drive coil vibrates the measuring tubes causing them to oscillate and produce a sine wave, 3. The sine wave is monitored by the two sensors.

### Energized Meter with Process Flow

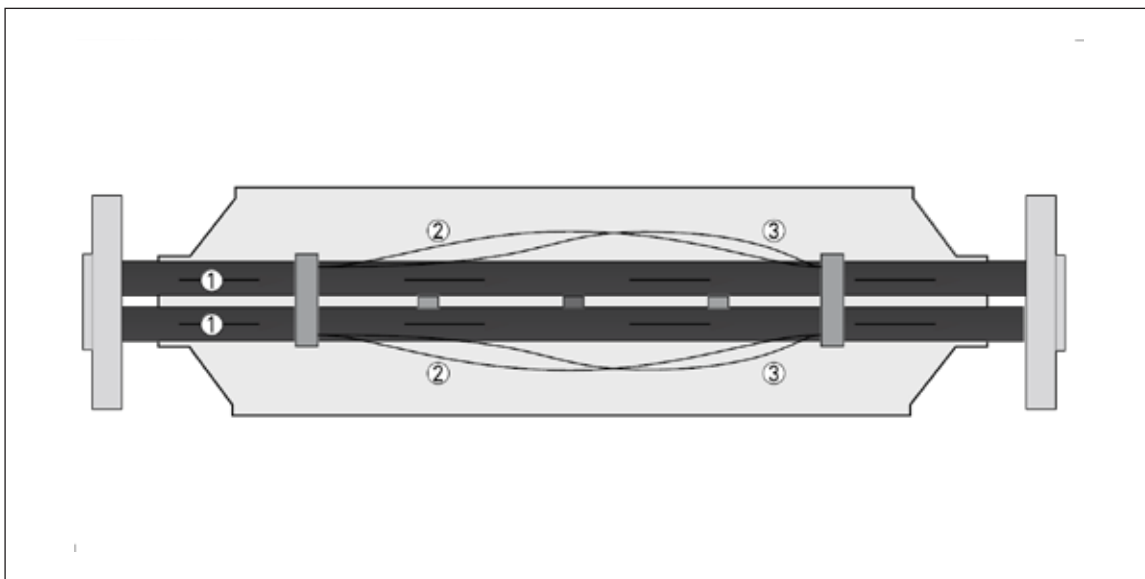

1. Process flow
2. Sine wave
3. Phase shift

When a fluid or gas passes through the tubes, the Coriolis effect causes a phase shift in the sine wave that is detected by the two sensors. This phase shift is directly proportional to the mass flow.

Density measurement is made by evaluation of the frequency of vibration, and temperature measurement is made using a Pt500 sensor.



## 2. TECHNICAL DATA

### 2.1 Technical Data

- The following data is provided for general applications. If you require data that is more relevant to your specific application, please contact us or your local sales office.
- Additional information and complete product documentation can be downloaded free of charge from the website.

<b>Measuring System</b>	
Measuring principle	Coriolis mass flow
Application range	Mass flow and density measurement of fluids, gases, and solids
Measured values	Mass, density, and temperature
Calculated values	Volume, referred density, concentration, and velocity
<b>Design</b>	
Basic	System consists of a measuring sensor and a converter to process the output signal
Features	Fully welded maintenance-free sensor with twin straight measuring tubes
<b>Variants</b>	
Compact version	Integral converter
Remote version	Available with field version of the converter
<b>Measuring accuracy</b>	
<b>Mass</b>	
Liquid	±0.15% of actual measured flow rate + zero stability
Gas	±0.35% of actual measured flow rate + zero stability
Repeatability	Better than 0.05% plus zero stability (includes the combined effects of repeatability, linearity and hysteresis)
<b>Zero Stability</b>	
Stainless Steel	±0.01% of maximum flow rate with respective sensor size
<b>Reference Conditions</b>	
Product	Water
Temperature	68°F / 20°C
Operating pressure	14.5 psig / 1 barg
Effect on sensor zero point caused by a shift in process temperature	
Stainless Steel	0.00055% per 1°F / 0.001% per 1°C
Effect on sensor zero point caused by a shift in process pressure	
Stainless Steel	0.0000083% of the max flow rate per 1 psig / 0.00012% of the max flow rate per 1 barrel
<b>Density</b>	
Measuring range	25 to 155 lbs/ft <sup>3</sup> 400 to 2500 kg/m <sup>3</sup>
Accuracy	±0.13 lbs/ft <sup>3</sup> / ±2 kg/m <sup>3</sup> / (S15: ±0.33 lbs/ft <sup>3</sup> / ±5 kg/m <sup>3</sup> )
On site calibration	±0.033 lbs/ft <sup>3</sup> / ±0.5 kg/m <sup>3</sup>
<b>Temperature</b>	
Accuracy	1.8°F ±1°C /

## 2. TECHNICAL DATA

### 2.1 Technical Data

<b>Operating Conditions</b>	
<b>Maximum Flow Rates</b>	
S15	240 lbs/min / 6500 kg/h
S25	990 lbs/min / 27000 kg/h
S40	2935 lbs/min / 80000 kg/h
S50	6235 lbs/min / 170000 kg/h
<b>Ambient Temperature</b>	
Compact version with Aluminum converter	-40 to +140°F
	Extended temperature range: +149°F / +65°C for some I/O options. For more information contact manufacturer.
Compact version with Stainless Steel converter	-40 to +130°F / -40 to +55°C
Remote versions	-40 to +149°F / -40 to +65°C
<b>Process temperature</b>	
Flanged connection	-40 to +266°F / -40 to +130°C
Hygienic connection	-40 to +266°F / -40 to +130°C
Nominal pressure at 20°C / 68°F	
<b>Measuring Tube</b>	
Stainless Steel	-14.5 to 1450 psig / -1 to 100 barg
Outer cylinder	
CRN approved	Typical burst pressure > 1450 psig at 68°F / 100 barg at 20°C
CRN approved secondary containment	-14.5 to 910 psig / -1 to 63 barg
<b>Fluid Properties</b>	
Permissible physical condition	Liquids, gases, slurries
Permissible gas content (volume)	Contact manufacturer for information
Permissible solid content (volume)	Contact manufacturer for information
Protection category (acc. to EN 60529)	IP 67, NEMA 4X
<b>Installation Conditions</b>	
Inlet runs	None required
Outlet runs	None required

## 2. TECHNICAL DATA

### 2.1 Technical Data

<b>Materials</b>	
Measuring tube	Stainless Steel UNS S31803 (1.4462)
Spigot	Stainless Steel 316 / 316L (CF3M / 1.4409) dual certified
Flanges	Stainless Steel 316 / 316L (1.4401 / 1.4404) dual certified
Outer cylinder	Stainless Steel 304 / 304L (1.4301 / 1.4307) dual certified
	Optional Stainless Steel 316 / 316L (1.4401 / 1.4404) dual certified
<b>Heating Jacket version</b>	
Heating jacket	Stainless Steel 316L (1.4404)
	The outer cylinder is in contact with the heating medium
<b>All Versions</b>	
Sensor electronics housing	Stainless Steel 316L (1.4409)
Junction box (remote version)	Die cast Aluminum (polyurethane coating)
	Optional Stainless Steel 316 (1.4401)
<b>Process Connections</b>	
<b>Flange</b>	
ASME	½ to 3" / ASME 150 to 600
DIN	DN15 to 80 / PN40 to 100
JIS	15 to 80A / 10 to 20K
<b>Hygienic</b>	
Tri-clover	1 to 3"
<b>Electrical Connections</b>	
Electrical connections	For full details, including: power supply, power consumption etc., see technical data for the relevant converter
I/O	For full details of I/O options, including data streams and protocols, see technical data for the relevant converter
<b>Approvals and Certifications</b>	
<b>Mechanical</b>	
Electromagnetic compatibility (EMC) acc. to CE	2004/108/EC (EMC)
	2006/95/EC (Low Voltage Directive)
Factory Mutual	Class I, Div 1 groups A, B, C, D
	Class II, Div 1 groups E, F, G
	Class III, Div 1 hazardous areas
	Class I, Div 2 groups A, B, C, D
	Class II, Div 2 groups F, G
	Class III, Div 2 hazardous areas
ANSI	12.27.901-2003

## 2. TECHNICAL DATA

### 2.3 Maximum Pipework Forces (End Loadings)

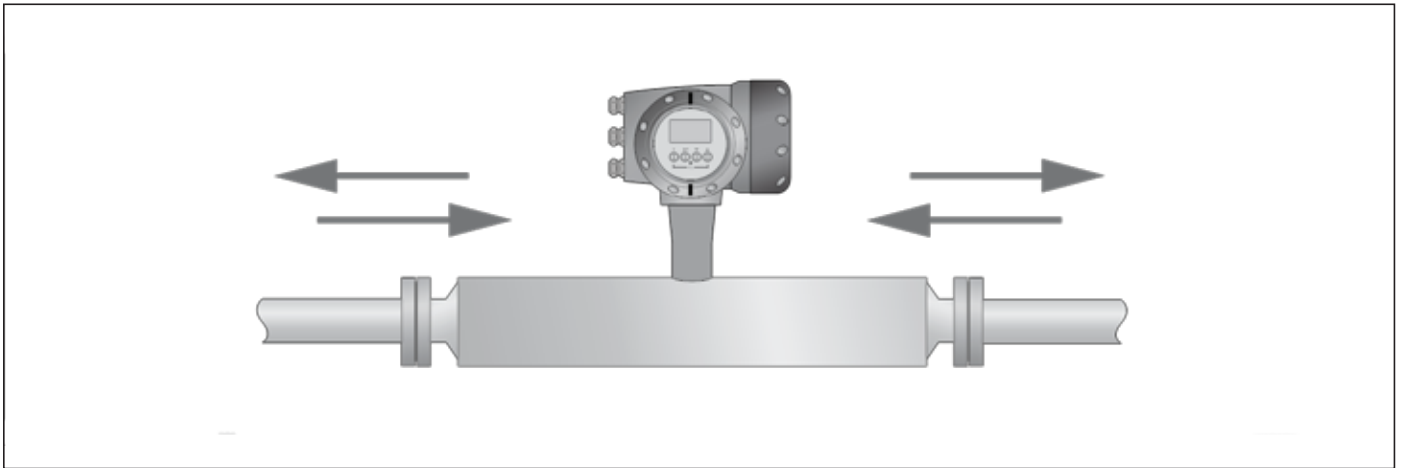

Mass flowmeters have a maximum level of force (negative or positive) that can be applied to the ends of the meter. Refer to the table below for permitted forces.

#### Maximum End Loadings

		S15	S25	S40	S50
<b>Flanges</b>					
68°F / 20°C	580 psig / 40 barg	5620lbs / 25kN	8542lbs / 38kN	10790lbs / 48kN	22256lbs / 99kN
	1450 psig / 100 barg	3821lbs / 17kN	4271lbs / 19kN	3372lbs / 15kN	4496lbs / 20kN
266°F / 130°C	464 psig / 32 barg	14046lbs / 8kN	6294lbs / 28kN	7868lbs / 35kN	16186lbs / 72kN
	1160 psig / 80 barg	2697lbs / 12kN	2697lbs / 12kN	1573lbs / 7kN	1798lbs / 8kN
<b>Hygienic (all connections)</b>					
266°F / 130°C	145 psig / 10 barg	1124lbs / 5kN	2032lbs / 9kN	2697lbs / 12kN	2697lbs / 12kN

- These (axial) loads have been calculated, based on 316L schedule 40 process pipework, where un-radiographed butt welds have been used in pipe joints.
- The loads shown are the maximum permitted static load. If loads are cycling (between tension and compression) these loads should be reduced. For advice, consult the manufacturer.

## 2. TECHNICAL DATA

### 2.4 Measuring Accuracy

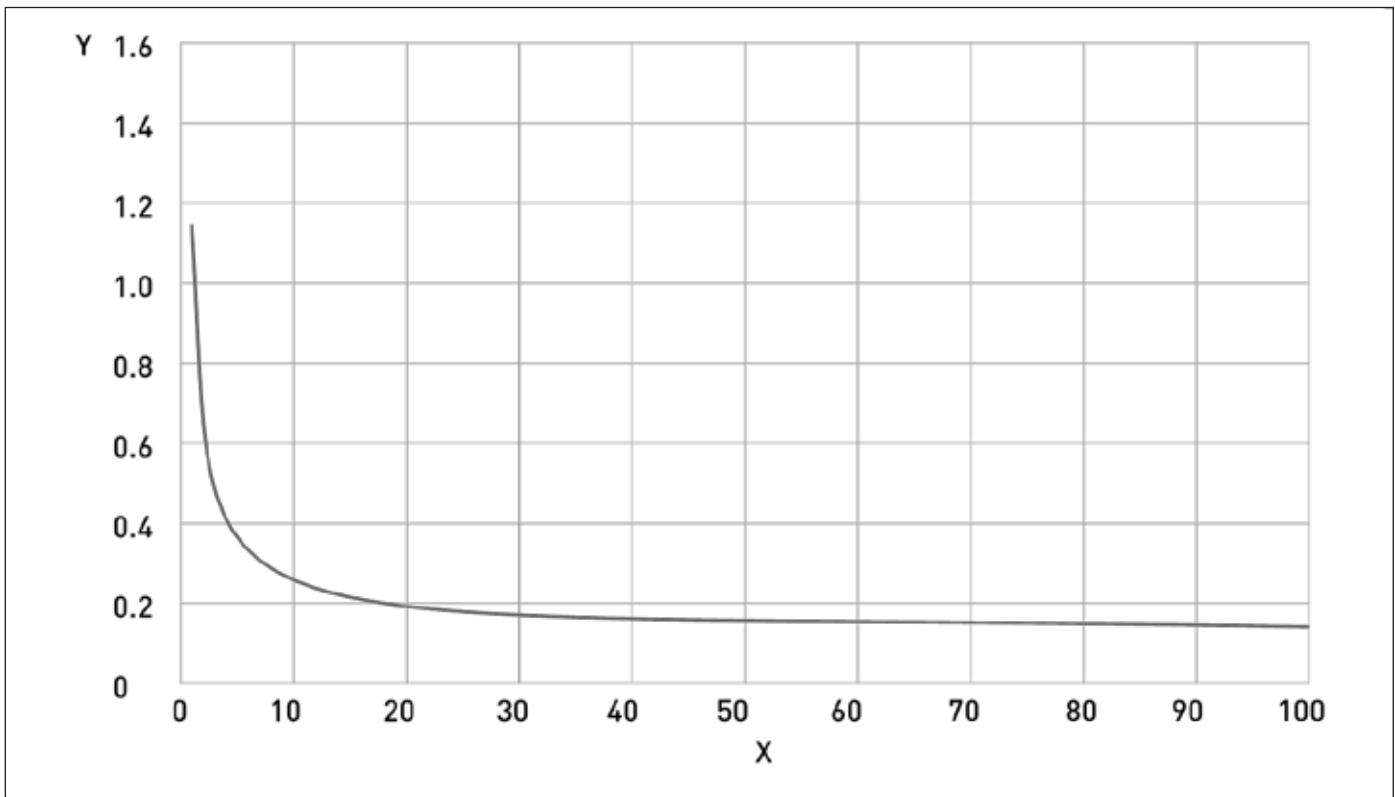

X flow rate [%]

Y measuring error [%]

#### Measuring Error

The measuring error is obtained from the combined effects of accuracy and zero stability.

Reference Conditions	
Product	Water
Temperature	+68°F / +20°C
Operating pressure	14.5 psig / 1 barg

## 2. TECHNICAL DATA

### 2.5 Guidelines for Maximum Operating Pressure

**Pressure / Temperature De-rating, All Meter Sizes, in Imperial  
(Flanged Connections as per ASME B16.5)**

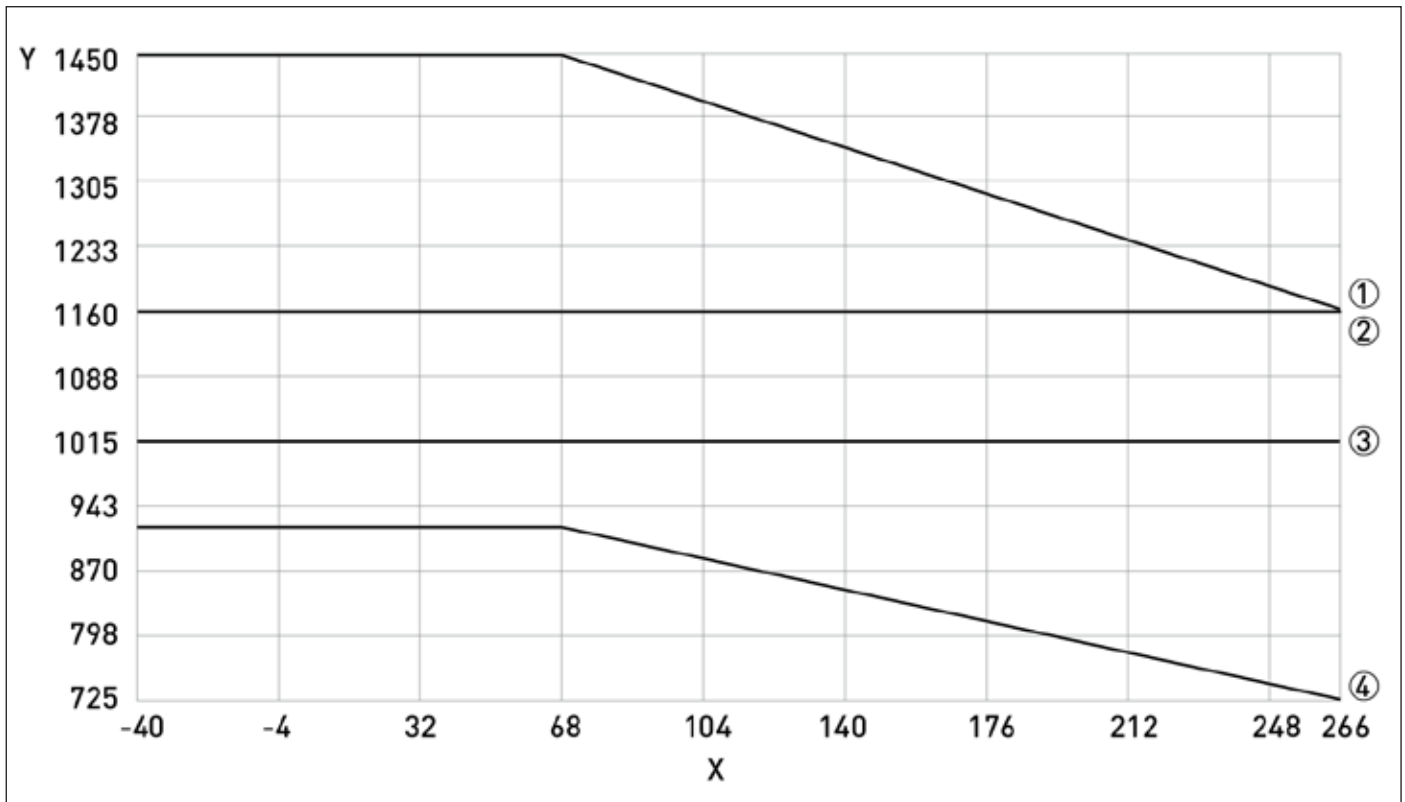

X temperature [°F]

Y pressure [psig]

1. Measuring tubes S15 / S25 (CRN)
2. Measuring tubes S40 (CRN)
3. Measuring tubes S50 (CRN)
4. Secondary containment 304L / 316L (CRN)

- Ensure that the meter is used within its operating limits

- All hygienic process connections have a maximum operating rating of 145 psig at 266°F / 10 barg at 130°C.

#### Flanges

- ASME flange ratings are based on ASME B16.5 2003 table 2 material group 2.2
- DIN flange ratings are based on EN 1092-1 2001 table 18 (1% proof stress) material group 14EO
- JIS flange ratings are based on JIS 2220: 2001 table 1 division 1 material group 022a

#### Notes

- The maximum operating pressure will be either the flange rating or the measuring tube rating, WHICHEVER IS LOWER!
- The manufacturer recommends that the seals are replaced at regular intervals. This will maintain the hygienic integrity of the connection.

## 2. TECHNICAL DATA

### 2.5 Guidelines for Maximum Operating Pressure

**Pressure / Temperature De-rating, All Meter Sizes, in Metric  
(Flanged Connections as per EN 1092-1)**

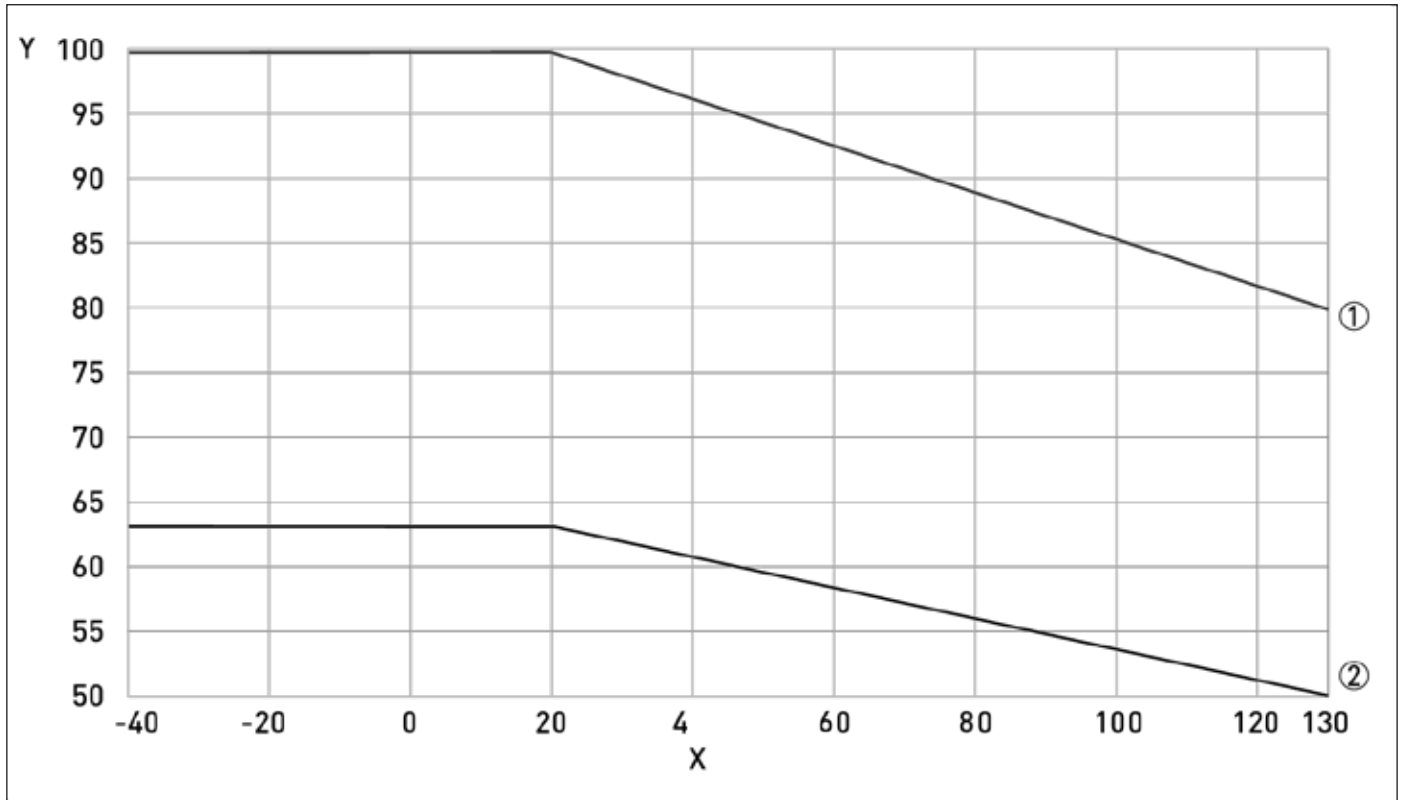

X temperature [°C]

Y pressure [barg]

1. Measuring tubes and 100barg 316L secondary containment (PED)
2. 63 barg 304L / 316 secondary containment (PED)

## 2. TECHNICAL DATA

### 2.6 Dimensions and Weights

#### 2.6.1 Flanged Versions

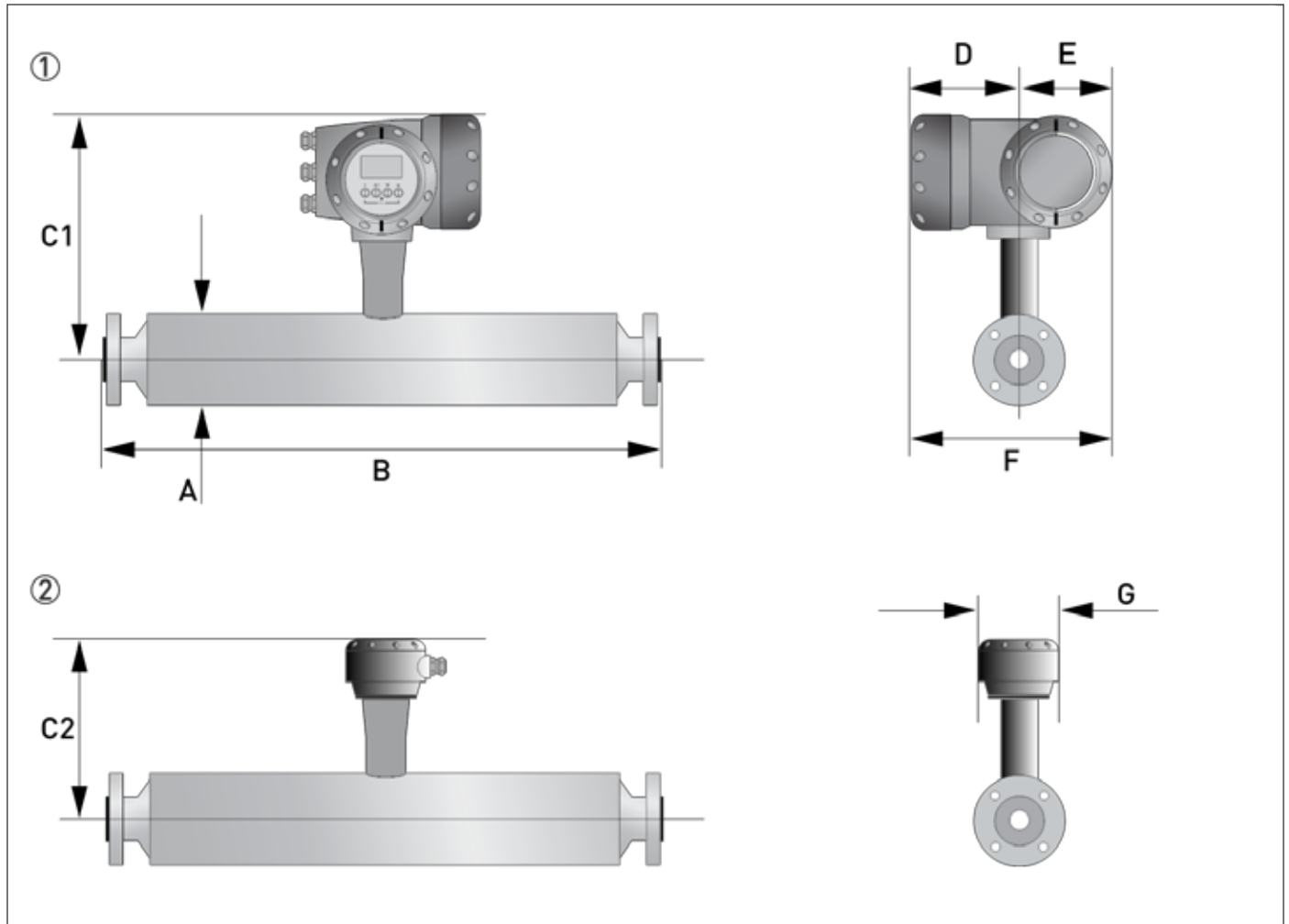

1. Compact version

2. Remote version



## 2. TECHNICAL DATA

### 2.6 Dimensions and Weights

#### 2.6.1 Flanged Versions

##### Meter Weights (All Flanges)

	Weight lbs / kg			
	S15	S25	S40	S50
Aluminum (compact)	30 / 13.5	36.3 / 16.5	65 / 29.5	127 / 57.5
Stainless Steel (compact)	41 / 18.8	48 / 21.8	77 / 34.8	138 / 62.8
Aluminum (remote)	25 / 11.5	32 / 14.5	56 / 25.5	113 / 51.5
Stainless Steel (remote)	27 / 12.4	33.8 / 15.4	58 / 26.4	115 / 52.4

##### Measuring Tube in Stainless Steel

	Dimensions inches / millimeters			
	S15	S25	S40	S50
A	4 / 101.6	4.5 / 114.3	6.6 / 168.3	8.6 / 219.1
C1 (compact)	12.2 / 311	12.5 / 317	13.5 / 344	14.6 / 370
C2 (remote)	9 / 231	9.3 / 237	10.4 / 264	11.4 / 290
D	6.3 / 160			
E	2.4 / 60			
F	4.9 / 123.5			
G	5.4 / 137			
H	3.9 / 98.5			

## 2. TECHNICAL DATA

### 2.6 Dimensions and Weights

#### 2.6.1 Flanged Versions

Flange Connections				
	Dimension B inches / millimeters			
	S15	S25	S40	S50
<b>ASME 150</b>				
1/2"	20.4 / 518	-	-	-
3/4"	20.8 / 528	-	-	-
1"	21 / 534	22.2 / 563	-	-
1 1/2"	-	22.5 / 575	29.1 / 740	-
2"	-	22.8 / 579	29.3 / 744	35.2 / 894
3"	-	-	29.8 / 756	35.7 / 906
4"	-	-	-	36.2 / 920
<b>ASME 300</b>				
1/2"	20.8 / 528	-	-	-
3/4"	21.2 / 538	-	-	-
1"	21.5 / 546	22.6 / 575	-	-
1 1/2"	-	23.2 / 589	29.7 / 754	-
2"	-	-	29.8 / 756	35.7 / 906
3"	-	-	-	36.4 / 926
<b>ASME 600</b>				
1/2"	21.3 / 541	-	-	-
3/4"	21.6 / 550	-	-	-
1"	22 / 558	23.2 / 589	-	-
1 1/2"	-	23.7 / 603	30.3 / 770	-
2"	-	-	30.5 / 774	36.4 / 926
3"	-	-	-	37.2 / 944

## 2. TECHNICAL DATA

### 2.6 Dimensions and Weights

#### 2.6.1 Flanged Versions

Flange Connections				
	Dimension B inches / millimeters			
	S15	S25	S40	S50
<b>PN40</b>				
DN15	19.6 / 498	-	-	-
DN25	19.8 / 503	21 / 531	-	-
DN40	20.2 / 513	21.3 / 541	27.8 / 706	-
DN50	-	21.5 / 547	28 / 712	33.9 / 862
DN80	-	-	28.8 / 732	34.7 / 882
DN100	-	-	-	35.3 / 896
<b>PN63</b>				
DN50	-	-	29 / 740	35 / 890
DN80	-	-	-	35.8 / 910
<b>PN100</b>				
DN15	20.2 / 513	-	-	-
DN25	21.2 / 538	22.3 / 567	-	-
DN40	-	22.6 / 575	29 / 740	-
DN50	-	-	29.6 / 752	35.5 / 902
DN80	-	-	-	36.3 / 922
<b>JIS 10K</b>				
50A	-	-	28 / 712	33.9 / 862
80A	-	-	-	34.7 / 882
<b>JIS 20K</b>				
15A	19.6 / 498	-	-	-
25A	19.8 / 503	20.9 / 531	-	-
40A	-	21.3 / 541	27.8 / 706	-
50A	-	-	28 / 712	33.9 / 862
80A	-	-	-	34.7 / 882

## 2. TECHNICAL DATA

### 2.6 Dimensions and Weights

#### 2.6.2 Hygienic Versions

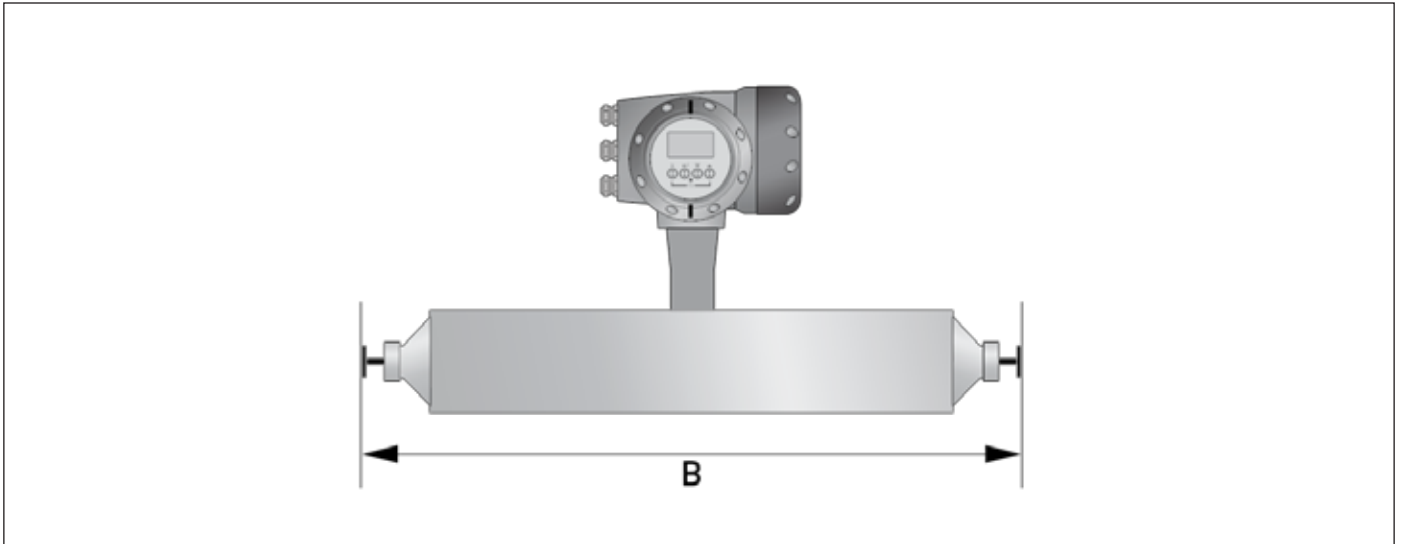

Hygienic Connections: All Welded Versions				
	Dimension B [inches]			
	S15	S25	S40	S50
<b>Tri-clover</b>				
1"	19.2 487	-	-	-
1½"	-	21 534	-	-
2"	-	-	27.2 691	-
3"	-	-	-	32.7 832

## 2. TECHNICAL DATA

### 2.6 Dimensions and Weights

#### 2.6.3 Heating Jacket Version

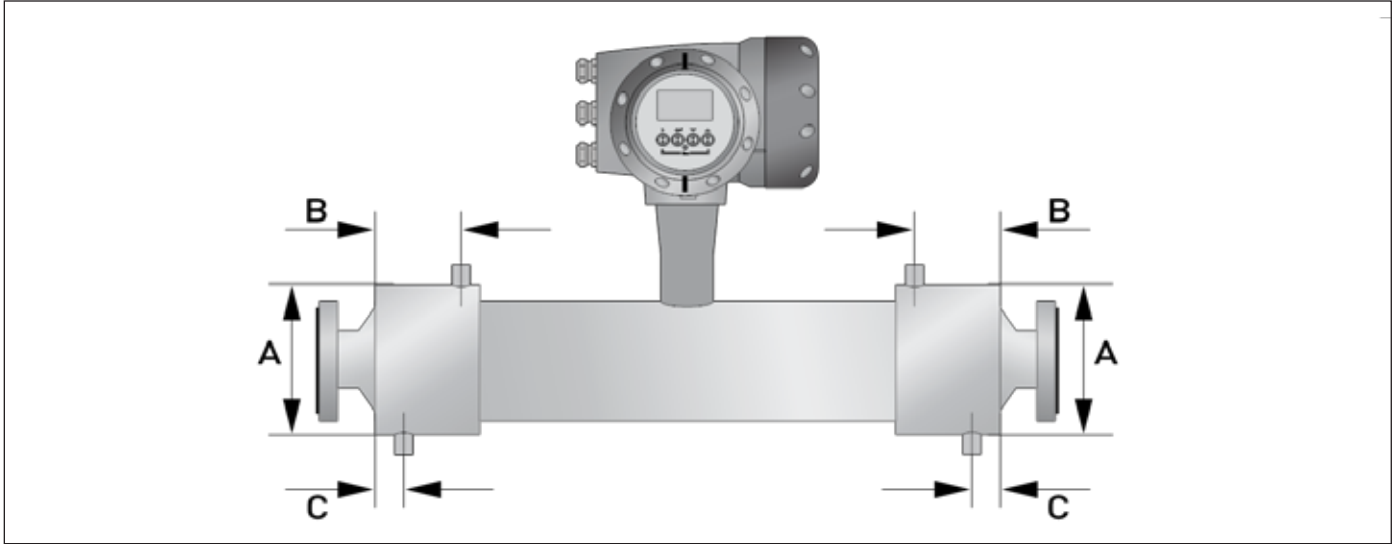

	Dimensions inches			
	S15	S25	S40	S50
Heating connection size	1/2" (NPTF)			1
A	4.5 ±0.04	5.6 ±0.04	8.1 ±0.04	10 ±0.04
B	2.0	2.2	3.5	4.1
C	0.8			1.0

## 2. TECHNICAL DATA

### 2.6 Dimensions and Weights

#### 2.6.4 Purge Port Option

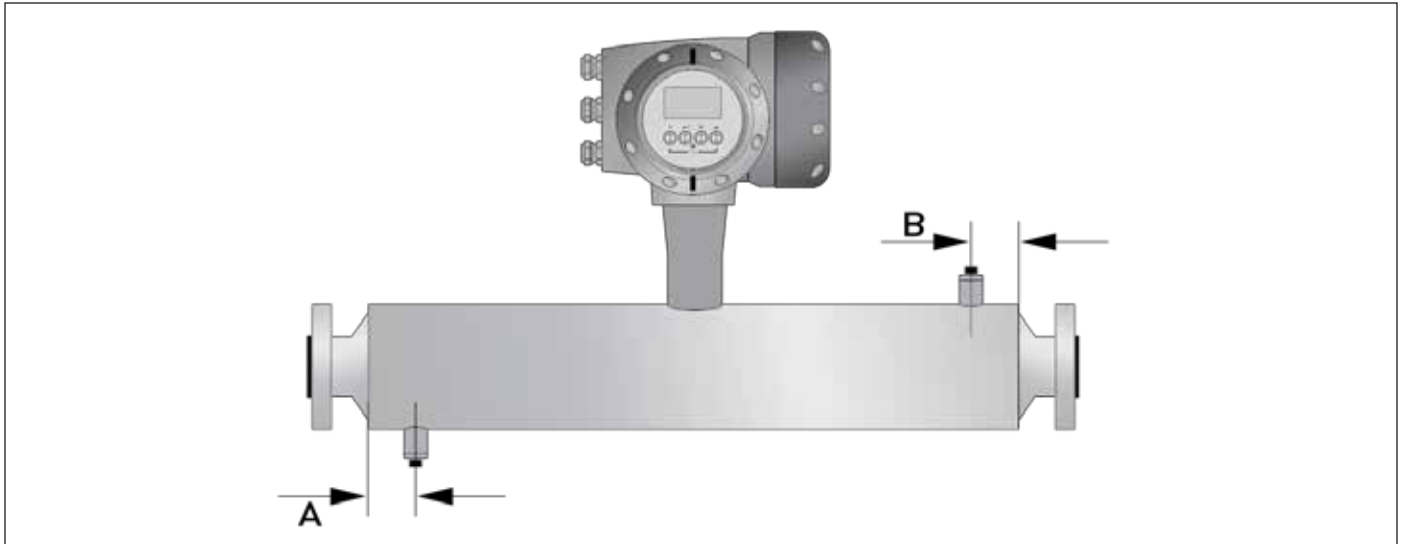

	Dimensions inches / millimeters			
	S15	S25	S40	S50
A	2.2 ±0.04	55 ±1.0	2.5 ±0.04	65 ±1.0
B	2.2 ±0.04	55 ±1.0	2.5 ±0.04	65 ±1.0

## 3. INSTALLATION

---

### 3.1 Intended Use

This mass flowmeter is designed for the direct measurement of mass flow rate, product density, and product temperature. Indirectly, it also enables the measurement of parameters like total mass,

concentration of dissolved substances, and the volume flow. For use in hazardous areas, special codes and regulations are also applicable and these are specified in a separate documentation.

### 3.2 Installation

#### 3.2.1 General Installation Principles

There are no special installation requirements, but note the following points:

- Support the weight of the meter.
- The meter can be supported on the sensor body.
- On larger meter sizes and hygienic connections, it is strongly recommended that the meter is not supported solely by the process pipework.
- No straight runs are required.
- The use of reducers and other fittings at flanges, including flexible hoses, is allowed, but take care to avoid cavitation.
- Avoid extreme pipe size reductions.
- Meters are not affected by crosstalk, and can be mounted in series or in parallel.
- Avoid mounting the meter at the highest point in the pipeline where air / gas can collect.

# 3. INSTALLATION

## 3.2 Installation

### 3.2.2 Mounting Positions

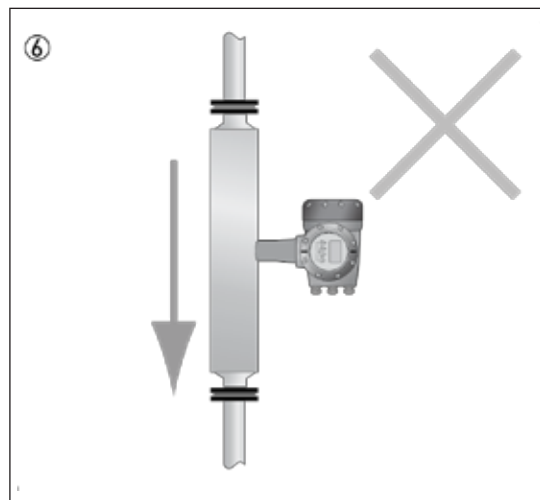
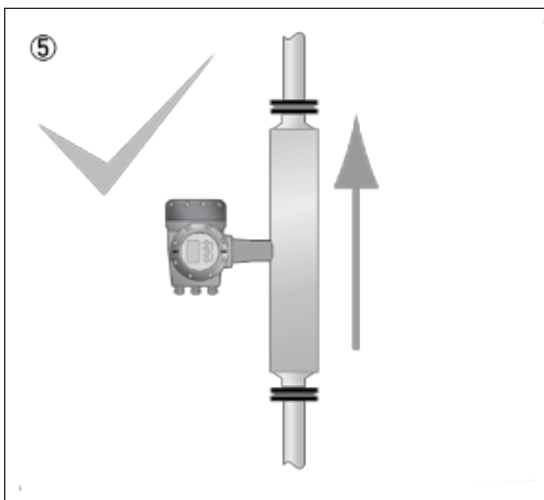
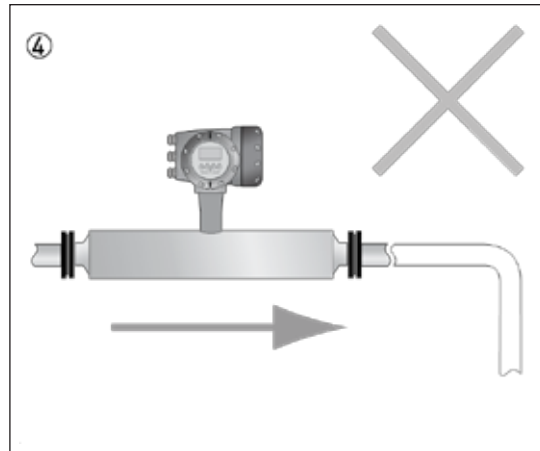
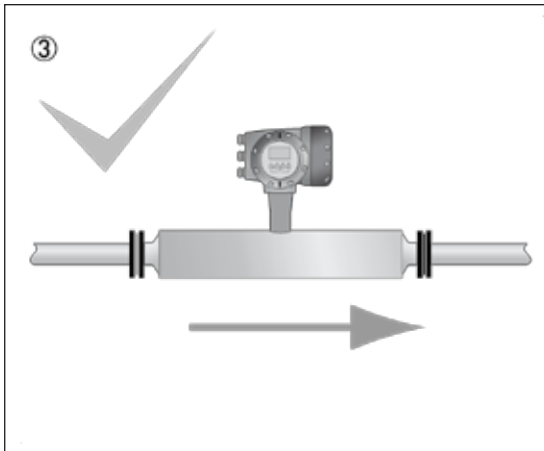
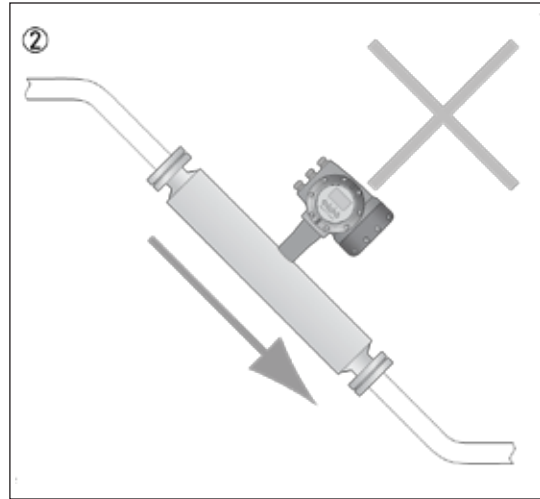
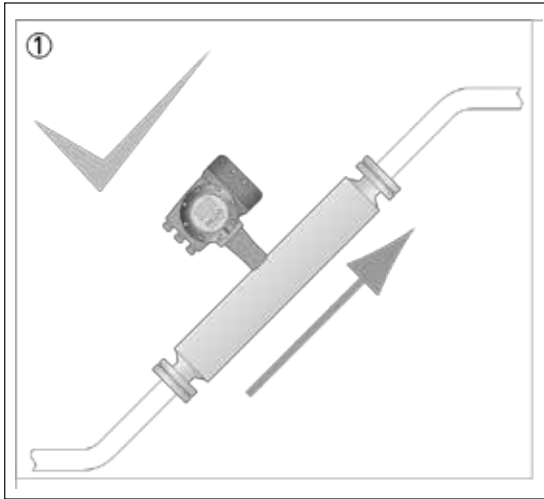

- 1 The meter can be mounted at an angle, but it is recommended that the flow is uphill.
- 2 Avoid mounting the meter with the flow running downhill because it can cause siphoning. If the meter has to be mounted with the flow running downhill, install an orifice plate or control valve downstream of the meter to maintain back-pressure.
- 3 Horizontal mounting with flow running left to right.
- 4 Avoid mounting meter with long vertical runs after the meter as it can cause cavitation. Where the installation includes a vertical run after the meter, install an orifice plate or control valve downstream to maintain back-pressure.
- 5 The meter can be mounted vertically but it is recommended that the flow is uphill.
- 6 Avoid mounting the meter vertically with the flow running downhill. This can cause siphoning. If the meter has to be installed this way, install an orifice plate or control valve downstream to maintain back-pressure.



# 3. INSTALLATION

## 3.2 Installation

### 3.2.3 Mounting for Zero Calibration

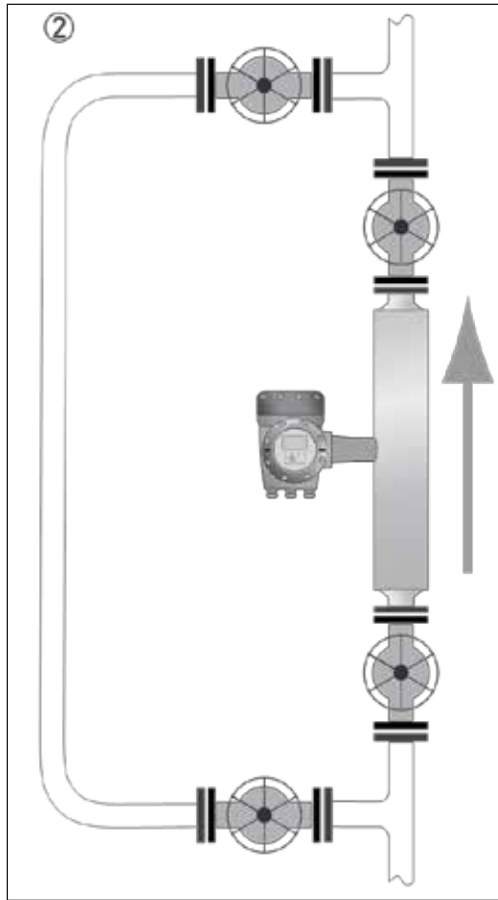
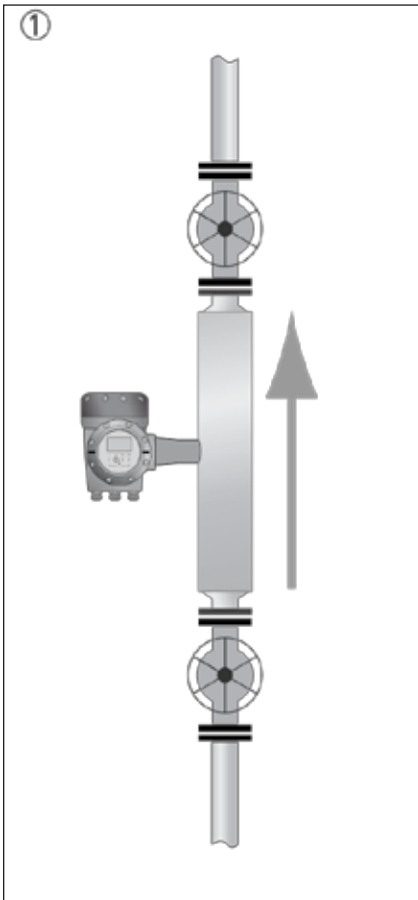

1. Where the meter has been installed vertically, install shut-off valves either on side of the meter to assist with zero calibration.
2. If the process flow cannot be stopped, install a bypass section for zero calibration.

### 3.2.4 Sunshades

The meter MUST be protected from strong sunlight.

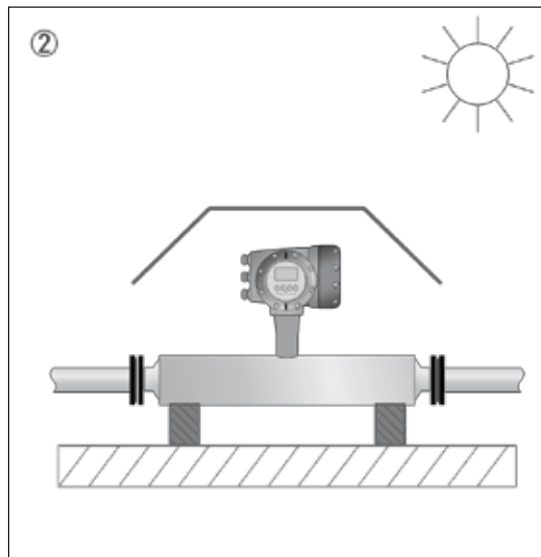
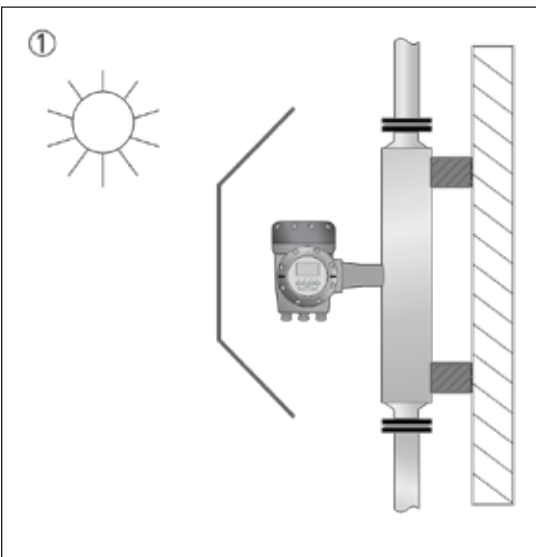

1. Vertical installation
2. Horizontal installation



Архангельск (8182)63-90-72  
Астана (7172)727-132  
Астрахань (8512)99-46-04  
Барнаул (3852)73-04-60  
Белгород (4722)40-23-64  
Брянск (4832)59-03-52  
Владивосток (423)249-28-31  
Волгоград (844)278-03-48  
Вологда (8172)26-41-59  
Воронеж (473)204-51-73  
Екатеринбург (343)384-55-89  
Иваново (4932)77-34-06  
Ижевск (3412)26-03-58  
Казань (843)206-01-48

Калининград (4012)72-03-81  
Калуга (4842)92-23-67  
Кемерово (3842)65-04-62  
Киров (8332)68-02-04  
Краснодар (861)203-40-90  
Красноярск (391)204-63-61  
Курск (4712)77-13-04  
Липецк (4742)52-20-81  
Магнитогорск (3519)55-03-13  
Москва (495)268-04-70  
Мурманск (8152)59-64-93  
Набережные Челны (8552)20-53-41  
Нижний Новгород (831)429-08-12  
Новокузнецк (3843)20-46-81

Новосибирск (383)227-86-73  
Омск (3812)21-46-40  
Орел (4862)44-53-42  
Оренбург (3532)37-68-04  
Пенза (8412)22-31-16  
Пермь (342)205-81-47  
Ростов-на-Дону (863)308-18-15  
Рязань (4912)46-61-64  
Самара (846)206-03-16  
Санкт-Петербург (812)309-46-40  
Саратов (845)249-38-78  
Севастополь (8692)22-31-93  
Симферополь (3652)67-13-56  
Смоленск (4812)29-41-54

Сочи (862)225-72-31  
Ставрополь (8652)20-65-13  
Сургут (3462)77-98-35  
Тверь (4822)63-31-35  
Томск (3822)98-41-53  
Тула (4872)74-02-29  
Тюмень (3452)66-21-18  
Ульяновск (8422)24-23-59  
Уфа (347)229-48-12  
Хабаровск (4212)92-98-04  
Челябинск (351)202-03-61  
Череповец (8202)49-02-64  
Ярославль (4852)69-52-93