

LCMASS 600

CORIOLIS MASS FLOW METER SYSTEMS



Архангельск (8182)63-90-72
Астана (7172)727-132
Астрахань (8512)99-46-04
Барнаул (3852)73-04-60
Белгород (4722)40-23-64
Брянск (4832)59-03-52
Владивосток (423)249-28-31
Волгоград (844)278-03-48
Вологда (8172)26-41-59
Воронеж (473)204-51-73
Екатеринбург (343)384-55-89
Иваново (4932)77-34-06
Ижевск (3412)26-03-58
Казань (843)206-01-48

Калининград (4012)72-03-81
Калуга (4842)92-23-67
Кемерово (3842)65-04-62
Киров (8332)68-02-04
Краснодар (861)203-40-90
Красноярск (391)204-63-61
Курск (4712)77-13-04
Липецк (4742)52-20-81
Магнитогорск (3519)55-03-13
Москва (495)268-04-70
Мурманск (8152)59-64-93
Набережные Челны (8552)20-53-41
Нижний Новгород (831)429-08-12
Новокузнецк (3843)20-46-81

Новосибирск (383)227-86-73
Омск (3812)21-46-40
Орел (4862)44-53-42
Оренбург (3532)37-68-04
Пенза (8412)22-31-16
Пермь (342)205-81-47
Ростов-на-Дону (863)308-18-15
Рязань (4912)46-61-64
Самара (846)206-03-16
Санкт-Петербург (812)309-46-40
Саратов (845)249-38-78
Севастополь (8692)22-31-93
Симферополь (3652)67-13-56
Смоленск (4812)29-41-54

Сочи (862)225-72-31
Ставрополь (8652)20-65-13
Сургут (3462)77-98-35
Тверь (4822)63-31-35
Томск (3822)98-41-53
Тула (4872)74-02-29
Тюмень (3452)66-21-18
Ульяновск (8422)24-23-59
Уфа (347)229-48-12
Хабаровск (4212)92-98-04
Челябинск (351)202-03-61
Череповец (8202)49-02-64
Ярославль (4852)69-52-93

LCMass[®] 600-640 Series

Mass Flow Sensor

Technical Data Sheet

- **HIGH ACCURACY**
The LCMass 600 achieves a $\pm 0.05\%$ accuracy on liquids for a 10:1 flow rate turn down ratio.
- **HIGH TURN DOWN**
The LCMass 600 achieves 20:1 turn down flow rate ratio while maintaining an accuracy of $\pm 0.1\%$.
- **ACCURATE DENSITY MANAGEMENT**
The LCMass achieves a density measurement accuracy of ± 0.008 lb/gal.
- **WIDE TEMPERATURE RANGE**
Accurately measures cryogenics at -328°F to high temperature with resistance up to 752°F .
- **ENTRAINED GAS MANAGEMENT**
State-of-the-art software monitors and manages entrained gas. This means the meter can send a alert when there is entrained gas present, all while measuring the liquid but not the gas.



LIQUID CONTROLS[®]

An IDEX Energy & Fuels Business

PUBLICATION UPDATES AND TRANSLATIONS

The most current English versions of all Liquid. It is the responsibility of the local distributor to provide the most current version of LC manuals, instructions, and specification sheets in the required language of the country, or the language of the end user to which the products are shipping. If there are questions about the language of any LC manuals, instructions, or specification sheets, please contact your local distributor.

The documentation is only complete when used in combination with the relevant documentation for the signal converter.

All rights reserved. It is prohibited to reproduce this documentation, or any part thereof, without the prior written authorization of Liquid Controls, LLC.

Content is subject to change without notice.



The documentation is only complete when used in combination with the relevant documentation for the signal converter.

TABLE OF CONTENTS

1. PRODUCT FEATURES

1.1 The Solution For Extended Temperature Applications	4
1.2 Features and Options. 5	
1.3 Meter / Converter Combinations.....	6

2. TECHNICAL DATA

2.1 Technical Data	8
2.2 Measuring Accuracy	16
2.3 Guidelines For Maximum Operating Pressure	17
2.4 Dimensions and Weights	22

3. INSTALLATION

3.1 Intended Use	32
3.2 Mounting Restrictions	32

1. PRODUCT FEATURES

1.1 The Solution For Extended Temperature Applications

A high level of performance, together with a wide operating temperature range up to 752°F / 400°C, makes the LCMass® 600 the ideal choice for mass flow measurement in a wide variety of applications.

Designed to meet the requirements of general purpose liquid and gas applications, the extended low temperature range of -328°F / -200°C also makes

the 600-640 suitable for Liquid Natural Gas (LNG) and cryogenic applications.

Combined with the power of the LCI40, the LCMass® 600-640 will provide accurate measurement of volume, mass, density, and concentration.



1. Standard flange process connections available.
2. Modular electronics with a range of output options.
3. Comprehensive diagnostic capabilities.

1. Remote terminal box

Features

- Innovative Twin V-Tube Design
- Temperature Range -328°F to 752°F / -200°C to +400°C
- Optional Insulation / Heating Jacket
- Compact Envelope
- Optimized Flow Divider for Minimum Pressure Loss
- Modular Electronics Concept: Electronics and Sensor Are Easy to Replace
- Self Draining When Mounted Vertically
- Stability With Entrained Gas, Even With Gas Concentrations from 0 to 100%

Industries

- Petrochemical
- Liquid Propane Gas (LPG)
- Upstream Oil and Gas
- Chemical
- Food and Beverage
- Water and Waste Water

Applications

- Tanker Loading
- Liquid Propane Gas (LPG)
- Supercritical Gases
- Crystallizing, Solidifying and Cryogenic Products
- General Purpose Applications
- CIP and SIP > 266°F / 130°C

1. PRODUCT FEATURES

1.2 Features and Options



Features

- Available as compact or remote.
- Nominal flow rates up to 11940 lb/min. / 325000 kg/h
- Self draining, when mounted vertically.

Heating Jacket and Purge Port

Heating Jacket

- For use with temperature-dependent products.
- Prevents solidification of process product.
- The heating case can also be used as a cryogenic insulation case.

Purge Port

- Allows hazardous chemicals to be drained away safely.



Connection Options

- Standard flanges with ratings up to 1500 lb / PN160.
- Supports a wide range of industry-standard hygienic connections.
- Optional sealing faces.

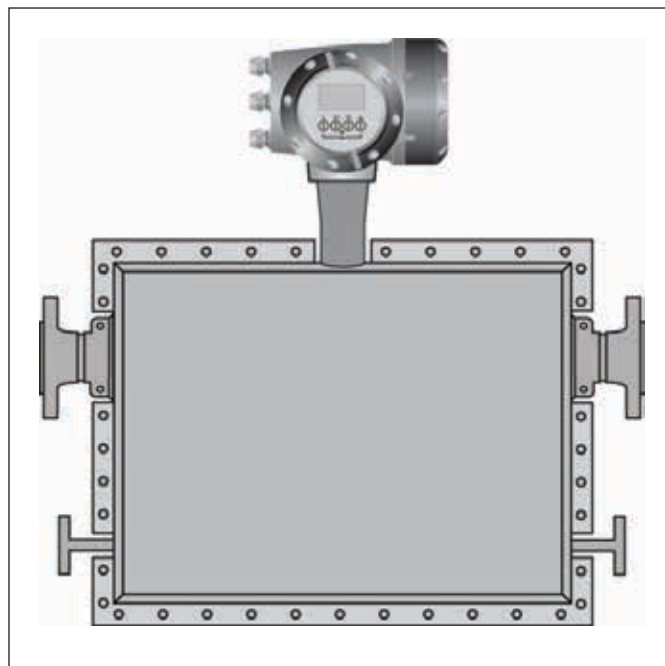

1. PRODUCT FEATURES

1.3 Meter / Converter Combinations

Converter	LCI40	
Configuration	Compact	Remote Field
LCMass® 600	640C	600F

1.4 Measuring Principle (Twin Tube)

Meter From the Side, Showing Tube Layout

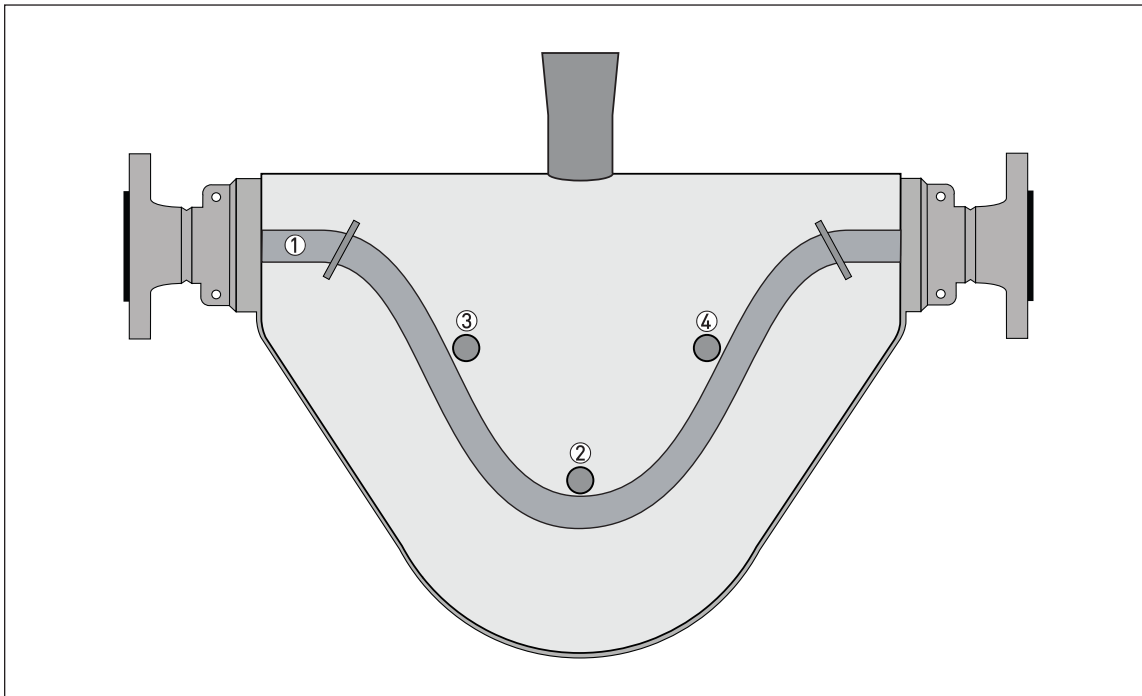

- ① Measuring tubes
- ② Drive coil
- ③ Sensor 1
- ④ Sensor 2

1. PRODUCT FEATURES

1.4 Measuring Principle (Twin Tube)

Static Meter not Energized and With No Flow

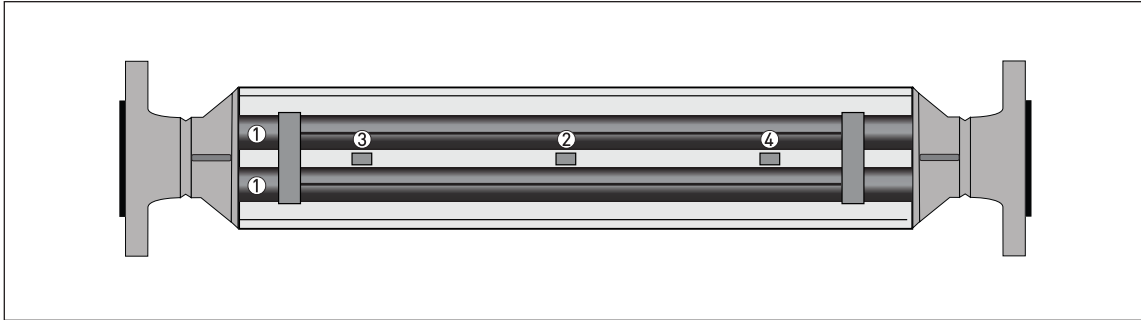

- ❶ Measuring tubes
 - ❷ Drive coil
 - ❸ Sensor 1
 - ❹ Sensor 2
- A Coriolis twin tube mass flowmeter consists of two measuring tubes ❶, a drive coil ❷, and two sensors ❸ and ❹ that are positioned on either side of the drive coil.

Energized Meter

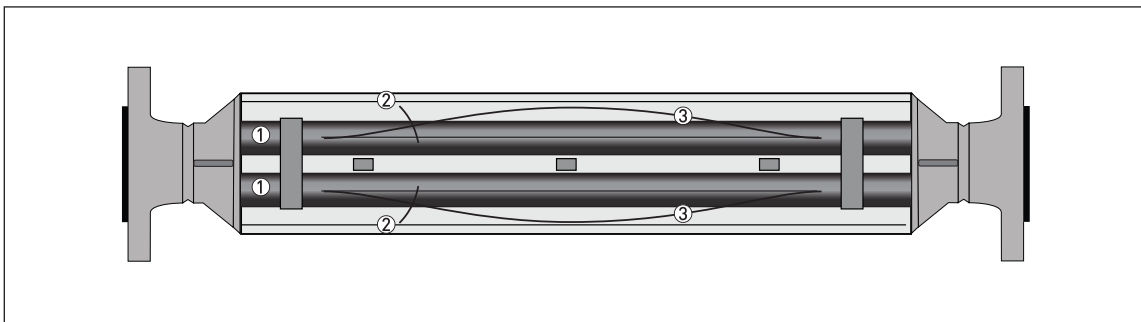

- ❶ Measuring tubes
 - ❷ Direction of oscillation
 - ❸ Sine wave
- When the meter is energized, the drive coil vibrates the measuring tubes causing them to oscillate and produce a sine wave ❸. The sine wave is monitored by the two sensors.

Energized Meter with Process Flow

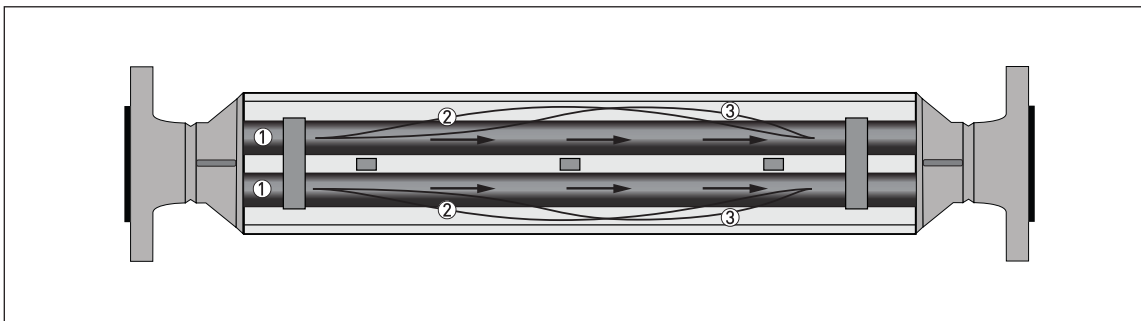

- ❶ Process flow
 - ❷ Sine wave
 - ❸ Phase shift
- When a fluid or gas passes through the tubes, the Coriolis effect causes a phase shift in the sine wave that is detected by the two sensors. This phase shift is directly proportional to the mass flow.
- Density measurement is made by evaluation of the frequency of vibration, and temperature measurement is made using a Pt500 sensor.

2. TECHNICAL DATA

2.1 Technical Data

The following data is provided for general applications. If you require data that is more relevant to your specific application, please contact us or your local sales office.

Measuring System	
Measuring Principle	Coriolis mass flow
Application Range	Mass flow and density measurement of fluids, gases and solids
Measured Values	Mass, density, temperature
Calculated Values	Volume, referred density, concentration, velocity
Sensor Model Range	
Stainless Steel 316L 08 to 250	Compact / remote 1450 psig @ 68°F / 100 barg @ 20°C, temp. range -94°F to +446°F / -70°C to +230°C
	Remote only 1450 psig @ 68°F / 100 barg @ 20°C, temp. range -58°F to +752°F / -50°C to +400°C
	Remote only 1450 psig @ 68°F / 100 barg @ 20°C / , temp. range -364°F to +104°F / -200°C to +40°C
Hastelloy® 08 to 80	Compact / remote 2900 psig @ 68°F / 200 barg @ 20°C, temp. range -58°F to +446°F / -70°C to +230°C /
Duplex Stainless Steel 100 to 200	Compact / remote 2900 psig @ 68°F / 200 barg @ 20°C, temp. range -58°F to +446°F / -50°C to +230°C

Design	
Basic	System consists of a measuring sensor and a converter to process the output signal
Features	Fully-welded maintenance-free sensor with twin V-shaped measuring tube
Variants	
Compact Version	Integral converter
Remote Version	Available with field or wall versions of the converter

2. TECHNICAL DATA

2.1 Technical Data

Measuring Accuracy		
Mass (standard)		
Liquid (\geq 20:1 of nominal flow rate)	$\pm 0.1\%$ of actual measured flow rate	
Liquid ($<$ 20:1 of nominal flow rate)	\pm zero stability (see zero stability below)	
Gas	$\pm 0.35\%$ of actual measured flow rate + zero stability	
Mass (optional)		
Liquid (\geq 10:1 of nominal flow rate)	$\pm 0.05\%$ of actual measured flow rate	
Liquid ($<$ 10:1 of nominal flow rate)	\pm zero stability (see zero stability below)	
Repeatability		
Liquid	Better than 0.05% plus zero stability (includes the combined effects of repeatability, linearity, and hysteresis)	
Gas	Better than 0.2% plus zero stability (includes the combined effects of repeatability, linearity, and hysteresis)	
Zero Stability	kg/hr	lbs/min
08	< 0.03	0.00110
10	< 0.06	0.00220
15	< 0.19	0.00697
25	< 0.95	0.00348
50	< 1.8	0.06600
80	< 3.9	0.14300
100	< 8.8	0.32267
150	< 16	0.58667
200	< 30	1.10000
250	< 50	1.83333
Reference Conditions		
Product	Water	
Temperature	+68°F / +20°C	
Operating pressure	14.5 psig / 1 barg	
Effect on sensor zero point caused by a shift in process temperature		
All materials sizes 08 to 10	0.00056% of nominal flow per 1°F / 0.0010% of nominal flow per 1°C	
All materials sizes 15 to 250	0.00042% of nominal flow per 1°F / 0.00075% of nominal flow per 1°C	
Pressure effect on mass flow rate		
All materials sizes 08 to 50	0.00034 % per 1 psig / 0.005% per 1 barg	
All materials sizes 80 to 100	0.00038 % per 1 psig / 0.0055% per 1 barg	
All materials sizes 150 to 250	0.00055 % per 1 psig / 0.008% per 1 barg	
Density		
Measuring range	6 to 187 lbs/ft ³ / 100 to 3000 kg/m ³	
Accuracy	± 0.06 lbs/ft ³ / ± 1 kg/m ³	
On site calibration	± 0.012 lbs/ft ³ / ± 0.2 kg/m ³	
Process temperature effect	0.0083 g/l per 1°F / 0.015 g/l per 1°C	
Temperature		
Accuracy	$\pm 0.9^\circ\text{F}$ / $\pm 0.5^\circ\text{C}$ ($\pm 0.5\%$ of reading)	

2. TECHNICAL DATA

2.1 Technical Data

Operating Conditions

Nominal Flow Rates (14.5 psig / 1 barg Pressure Drop)

08	22 lbs/min / 600 kg/h
10	44 lbs/min / 1200 kg/h
15	139 lbs/min / 3800 kg/h
25	698 lbs/min / 19000 kg/h
50	1286 lbs/min / 35000 kg/h
80	2866 lbs/min / 78000 kg/h
100	6430 lbs/min / 175000 kg/h
150	11758 lbs/min / 320000 kg/h
200	20209 lbs/min / 550000 kg/h
250	36743 lbs/min / 1000000 kg/h
	Assumes operating density 62.4 lb/ft ³ / 1000 kg/m ³
	For Hastelloy® meters, assume a pressure drop of 1.15 barg

Maximum Flow Rates

All Meters	150% of nominal flow rate
Ambient Temperature	
Compact Version With Aluminum Converter	-40 to +149°F / -40 to +65°C
Compact Version With Stainless Steel Converter	-40 to +131°F / -40 to +55°C
Remote Versions	Standard temperature range: -40 to +149°F / -40 to +65°C
	Cryogenic temperature range: -4 to +149°F / -20 to +65°C
Hazardous Area Versions	Refer to temperature limits

2. TECHNICAL DATA

2.1 Technical Data

Operating Conditions		
Process Temperatures		
Standard Temperature Range (Flange Connections)		
Safe Area	-94 to +446°F / -70 to +230°C	
Hazardous Area	-58 to +446°F / -50 to +230°C	
High Temperature Range	-58 to +752°F / -50 to +400°C	
Cryogenic Temperature Range	-328 to +104°F / -200 to +40°C	
Standard Temperature Range (Hygienic Connections)		
Safe Area	-94 to +302°F / -70 to +150°C	
Hazardous Area	-58 to +302°F / -50 to +150°C	
Nominal Pressure At 68°F / 20°C		
Measuring Tube	SS 316 / 316L	Hastelloy® C22 / S31803
FM	-14.5 to 1450 psig / -1 to 100 barg	-14.5 to 2900 psig / -1 to 200 barg
CRN / ASME B31.3	-14.5 to 1450 psig / -1 to 100 barg	Pending
Outer Casing Burst Pressure		
08	≈ 1450 psig / 100 barg	
10		
15		
25	≈ 1015 psig / 70 barg	
50		
80		
100	≈ 145 psig / 10 barg	
150		
200		
250		
If the process temperature is higher than 68°F / 20°C, the burst pressure will be lower. For more information please contact the manufacturer.		
Fluid Properties		
Permissible Physical Condition	Liquids, gases, slurries	
Permissible Gas Content (Volume)	Contact manufacturer for information.	
Permissible Solid Content (Volume)	Contact manufacturer for information.	
Protection Category (Acc. To EN 60529)	IP 67, NEMA 4X	
Installation Conditions		
Inlet / Outlet Runs	None required	

2. TECHNICAL DATA

2.1 Technical Data

Materials	
Stainless Steel (316 / 316L) Meter	
Measuring tubes / Flanges	Stainless Steel AISI 316 / 316L (1.4401 / 1.4404) dual certified
Spigots	Stainless Steel CF3M (1.4409)
Bridge	Stainless Steel AISI 304 / 304L (1.4301 / 1.4307) dual certified or AISI 316 / 316L (1.4401 / 1.4404) dual certified
Outer casing	Stainless Steel AISI 316 / 316L (1.4401 / 1.4404) dual certified
Stainless Steel (S31803) Meter	
Measuring tubes / Flanges	Stainless Steel UNS 31803 (1.4462)
Spigots	Stainless Steel J92205 (1.4470)
Bridge	Stainless Steel AISI 304 / 304L (1.4301 / 1.4307) dual certified or AISI 316 / 316L (1.4401 / 1.4404) dual certified
Outer casing	Stainless Steel AISI 316 / 316L (1.4401 / 1.4404) dual certified
Hastelloy® C22 Meter	
Measuring tubes / raised face	Hastelloy® C22
(Backing) flanges	Stainless Steel AISI 316 / 316L (1.4401 / 1.4404) dual certified
Bridge	Stainless Steel AISI 316 / 316L (1.4401 / 1.4404) dual certified
Outer casing	Stainless Steel AISI 316L (1.404) dual certified
Heating Jacket Version	
Heating loop and insulation jacket	Stainless Steel AISI 316 (1.4401)
All Versions	
Junction box (remote version)	Die-cast Aluminum (polyurethane coating)
	Optional Stainless Steel 316 (1.4401)
Process Connections	
Flange	
DIN (EN 1092-1 2007)	DN10 to 300 / PN16 to 160
ASME (B616.5)	½ to 12" / ASME 150 to 1500
JIS (2220 2001)	10A to 300A / 10 to 20K (10K maximum allowable temperature 572°F / 300°C)
Hygienic (08 to 50 only)	
Tri-clover	¾ to 3"
Electrical	
Electrical connections	For full details, including: power supply, power consumption etc., see technical data for the relevant signal converter.
I/O	For full details of I/O options, including data streams and protocols, see technical data for the relevant signal converter.
Electromagnetic compatibility (EMC) acc. to CE	2004/108/EC (EMC)
	2006/95/EC (Low Voltage Directive)
Approvals	
Mechanical	
CRN	Acc. to ASME B31.3 (pending)

2. TECHNICAL DATA

2.1 Technical Data

Temperature Limits		
LCMass® 640 / 600F With or Without Heating Jacket / Insulation		
Ambient temp. Tamb °F / °C	Medium temp. Tm °F / °C	Maximum surface temp. °F / °C
-40 to 104 / -40 to 40	-58 to 104 / -50 to 40	176 / 80
	-58 to 302 / -50 to 150	374 / 190
	-58 to 446 / -50 to 230	518 / 270
-40 to 131 / -40 to 55	-58 to 104 / -50 to 40	176 / 80
	-58 to 302 / -50 to 150	374 / 190
	--58 to 446 / -50 to 230	518 / 270
-40 to 149 / -40 to 65	-58 to 104 / -50 to 40	176 / 80
	-58 to 302 / -50 to 150	374 / 190
	-58 to 446 / -50 to 230	518 / 270
Cryogenic Version		
-4 to 149 / -20 to 65	-328 to 104 / -200 to 40	176 / 80
640C With Aluminum Converter housing, With or Without Heating Jacket / Insulation		
-40 to 104 / -40 to 40	-58 to 104 / -50 to 40	176 / 80
	-58 to 302 / -50 to 150	374 / 190
	-58 to 446 / -50 to 230	518 / 270
-40 to 122 / -40 to 50	-58 to 104 / -50 to 40	176 / 80
	-58 to 302 / -50 to 150	374 / 190
	-58 to 446 / -50 to 230	518 / 270
-40 to 149 / -40 to 65	--58 to 149 / 50 to 65	221 / 105
Cryogenic Version		
-40 to 149 / -40 to 65	-328 to 104 / -200 to 40	176 / 80
LCMass® 640C With SS Converter Housing, With or Without Heating Jacket / Insulation		
-40 to 104 / -40 to 40	-58 to 104 / -50 to 40	176 / 80
	-58 to 302 / -50 to 150	374 / 190
	-58 to 446 / -50 to 230	518 / 270
-40 to 122 / -40 to 50	-58 to 104 / -50 to 40	176 / 80
	-58 to 302 / -50 to 150	374 / 190
	-58 to 446 / -50 to 230	518 / 270
-40 to 140 / -40 to 60	-58 to 140 / -50 to 60	201 / 100
Cryogenic Version		
-13 to 140 / -25 to +60	-328 to 104 / -200 to 40	176 / 80

2. TECHNICAL DATA

2.1 Technical Data

Temperature Limits , continued

High Temperature Versions

LCMass® 640F - HT With Aluminum Junction Box, Heating Jacket and Insulation

-40 to 104 / -40 to 40	-58 to 104 / -50 to 40	176 / 80
	-58 to 446 / -50 to 230	518 / 270
	-58 to 752 / -50 to 400	824 / 440
-40 to 131 / -40 to 55	-58 to 104 / -50 to 40	176 / 80
	-58 to 446 / -50 to 230	518 / 270
	-58 to 752 / -50 to 400	824 / 440
-40 to 140 / -40 to 60	-58 to 104 / -50 to 40	176 / 80
	-58 to 446 / -50 to 230	518 / 270
	-58 to 752 / -50 to 400	824 / 440
-40 to 149 / -40 to 65	-58 to 662 / -50 to 350	734 / 390

LCMass® 640F - HT With SS Junction Box, Heating Jacket and Insulation

-40 to 104 / -40 to 40	-58 to 104 / -50 to 40	176 / 80
	-58 to 446 / -50 to 230	518 / 270
	-58 to 752 / -50 to 400	824 / 440
-40 to 122 / -40 to 50	-58 to 104 / -50 to 40	176 / 80
	-58 to 446 / -50 to 230	518 / 270
	-58 to 752 / -50 to 400	824 / 440
-40 to 131 / -40 to 55	-58 to 104 / -50 to 40	176 / 80
	-58 to 446 / -50 to 230	518 / 270
	-58 to 752 / -50 to 400	824 / 440
-40 to 140 / -40 to 60	-58 to 662 / -50 to 350	734 / 390

LCMass® 640F - HT With Aluminum or SS Junction Box, Insulation but no Heating Jacket

-40 to 104 / -40 to 40	-58 to 104 / -50 to 40	176 / 80
	-58 to 446 / -50 to 230	518 / 270
	-58 to 752 / -50 to 400	824 / 440
-40 to 131 / -40 to 55	-58 to 104 / -50 to 40	176 / 80
	-58 to 446 / -50 to 230	518 / 270
	-58 to 752 / -50 to 400	824 / 440
-40 to 149 / -40 to 65	-58 to 104 / -50 to 40	176 / 80
	-58 to 446 / -50 to 230	518 / 270
	-58 to 752 / -50 to 400	824 / 440

2. TECHNICAL DATA

2.1 Technical Data

Maximum End Loadings (Stainless Steel 316 / 316L)										
		S08 / S10	S15	S25	S50	S80	S100	S150	S200	S250
Flanges										
68°F / 20°C	580 psig / 40 barg	3372 lbs / 15 kN	5620 lbs / 25 kN	8542 lbs / 38 kN	10790 lbs / 48 kN	22256 lbs / 99 kN	29225 lbs / 130 kN	56202 lbs / 250 kN	67442 lbs / 300 kN	78683 lbs / 350 kN
	1450 psig / 100 barg	2697 lbs / 12 kN	3821 lbs / 17 kN	4271 lbs / 19 kN	3372 lbs / 15 kN	4496 lbs / 20 kN	22480 lbs / 100 kN	33721 lbs / 150 kN	33721 lbs / 150 kN	44961 lbs / 200 kN
446°F / 230°C	464 psig / 32 barg	1573 lbs / 7 kN	2697 lbs / 12 kN	4046 lbs / 18 kN	5620 lbs / 25 kN	10116 lbs / 45 kN	13488 lbs / 60 kN	33721 lbs / 150 kN	44961 lbs / 200 kN	56202 lbs / 250 kN
	870 psig / 60 barg	1124 lbs / 5 kN					4496 lbs / 20 kN			
752°F / 400°C	397 psig / 27.4 barg	1124 lbs / 5 kN	1347 lbs / 6 kN	2248 lbs / 10 kN	2697 lbs / 12 kN	4496 lbs / 20 kN	11240 lbs / 50 kN	17984 lbs / 80 kN	22480 lbs / 100 kN	33721 lbs / 150 kN
	580 psig / 40 barg	898 lbs / 4 kN	1124 5 lbs / kN				4496 lbs / 20 kN			
Hygienic (all connections)										
302°F / 150°C	145 psig / 10 barg	1124 lbs / 5 kN	2023 lbs / 9 kN	2697 lbs / 12 kN	2697 lbs / 12 kN	4046 lbs / 18 kN	N/A	N/A	N/A	N/A

Maximum End Loadings (Hastelloy® and Stainless Steel UNS S31803)										
		H08 / H10	H15	H25	H50	H80	D100	D150	D200	
Flanges (not including CRN)										
68°F / 20°C	44961 psig / 200 barg	2697 lbs / 12 kN	3821 lbs / 17 kN	4271 lbs / 19 kN	3372 lbs / 15 kN	4496 lbs / 20 kN	22480 lbs / 100 kN	33721 lbs / 150 kN		
	3260 psig / 145 barg	1124 lbs / 5 kN				4496 lbs / 20 kN				
Flanges (CRN Regions)										
68°F / 20°C	44961 psig / 200 barg ¹	2697 lbs / 12 kN	3821 lbs / 17 kN	4271 lbs / 19 kN	3372 lbs / 15 kN	4496 lbs / 20 kN	13488 lbs / 60 kN	6744 / 30 kN	2248 lbs / 10 kN	
	446°F / 230°C	3260 psig / 145 barg ²	1124 lbs / 5 kN				4496 lbs / 20 kN			

1 D200 limited to 180 barg at 20°C

2 D100 and D150 limited to 120 barg at 230°C. D200 limited to 110 barg at 230°C

- DN08 to 50 (axial) loads have been calculated, based on 316L schedule 40 process pipework, where un-radiographed butt welds have been used in pipe joints.
- DN80 to 250 (axial) loads have been calculated, based on 316L schedule 80 process pipework, where un-radiographed butt welds have been used in pipe joints.
- The loads shown are the maximum permitted static load. If loads are cycling (between tension and compression) these loads should be reduced. For advice, consult the manufacturer.

2. TECHNICAL DATA

2.2 Measuring Accuracy

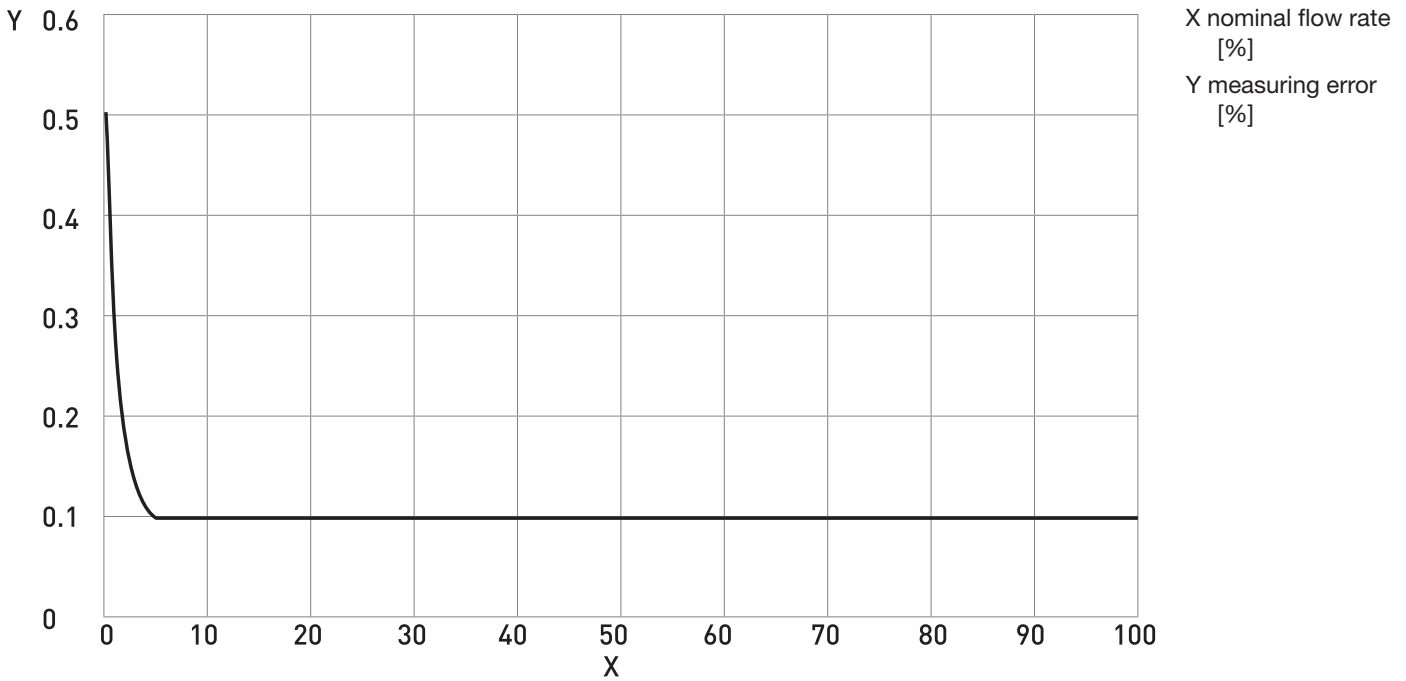

Measuring Error

The measuring error is obtained from the combined effects of accuracy and zero stability.

Reference Conditions

Product	Water
Temperature	+68°F / +20°C
Operating pressure	14.5 psig / 1 barg

2.3 Guidelines For Maximum Operating Pressure

Ensure that the meter is used within its operating limits

All hygienic process connections have a maximum operating rating of 145 psig at 302°F / 10 barg at 150°C

2. TECHNICAL DATA

2.3 Guidelines For Maximum Operating Pressure

Standard Temperature Range

Pressure / temperature de-rating (imperial) for meters with SS 316 measuring tubes.

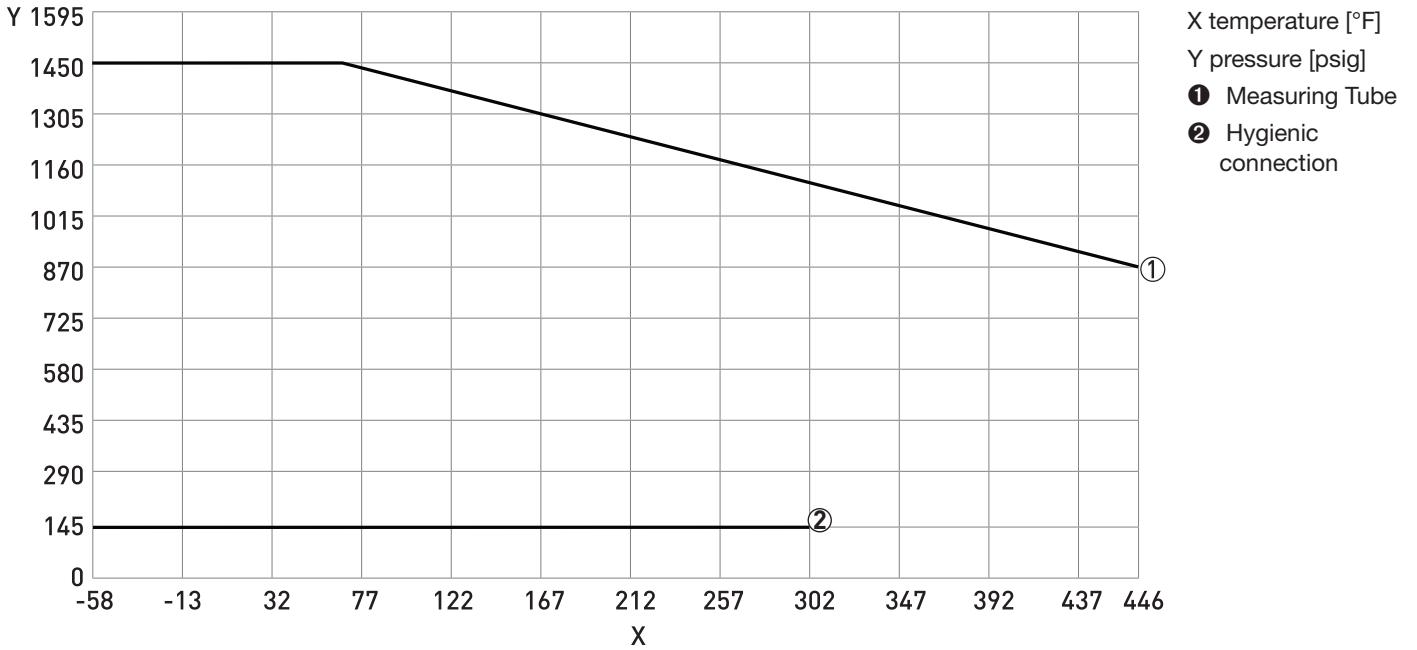

Pressure / temperature de-rating (metric) for meters with SS 316 measuring tubes.

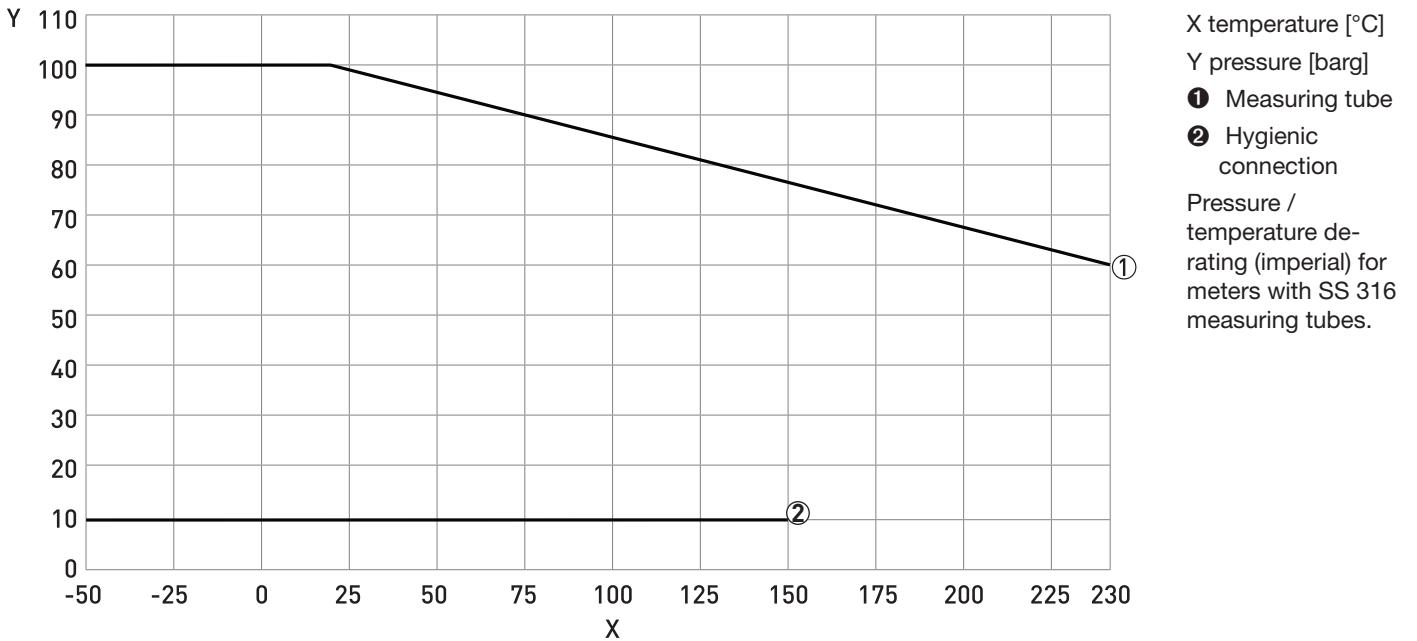

2. TECHNICAL DATA

2.3 Guidelines For Maximum Operating Pressure

High Temperature Range

Pressure / temperature de-rating (imperial) for meters with SS 316

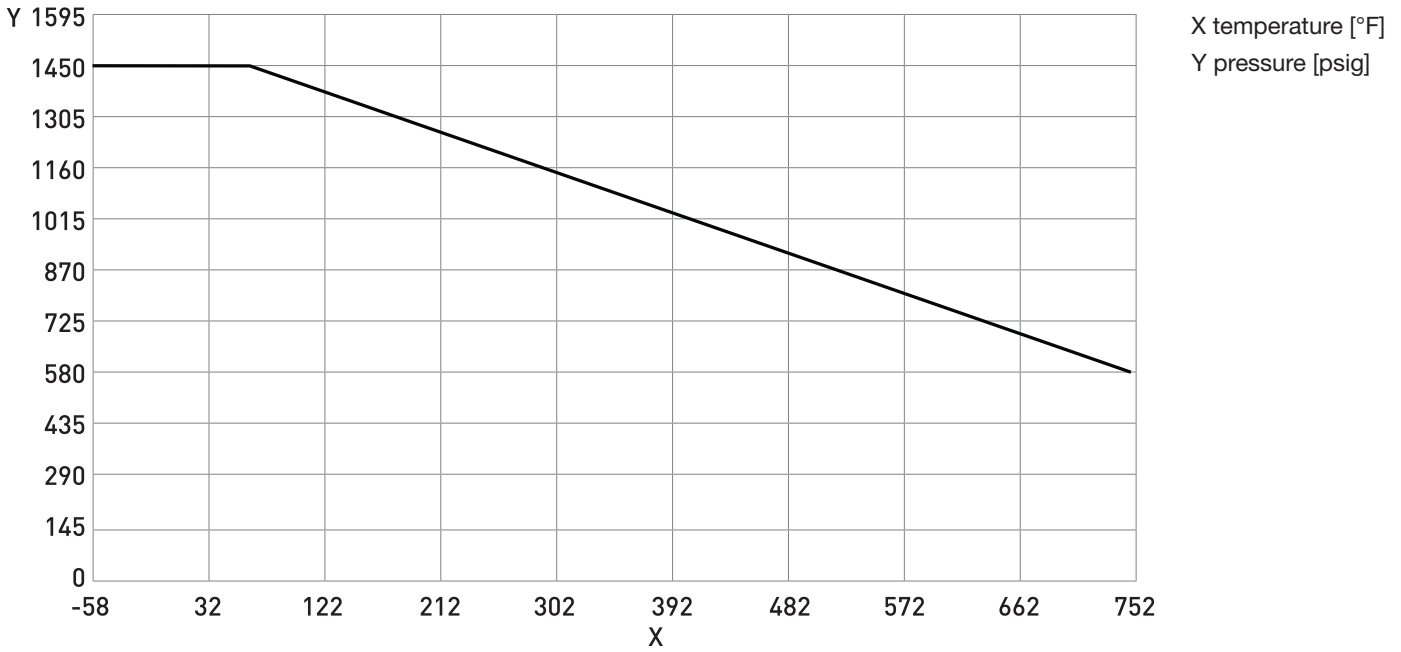

Pressure / temperature de-rating (metric) for meters with SS 316

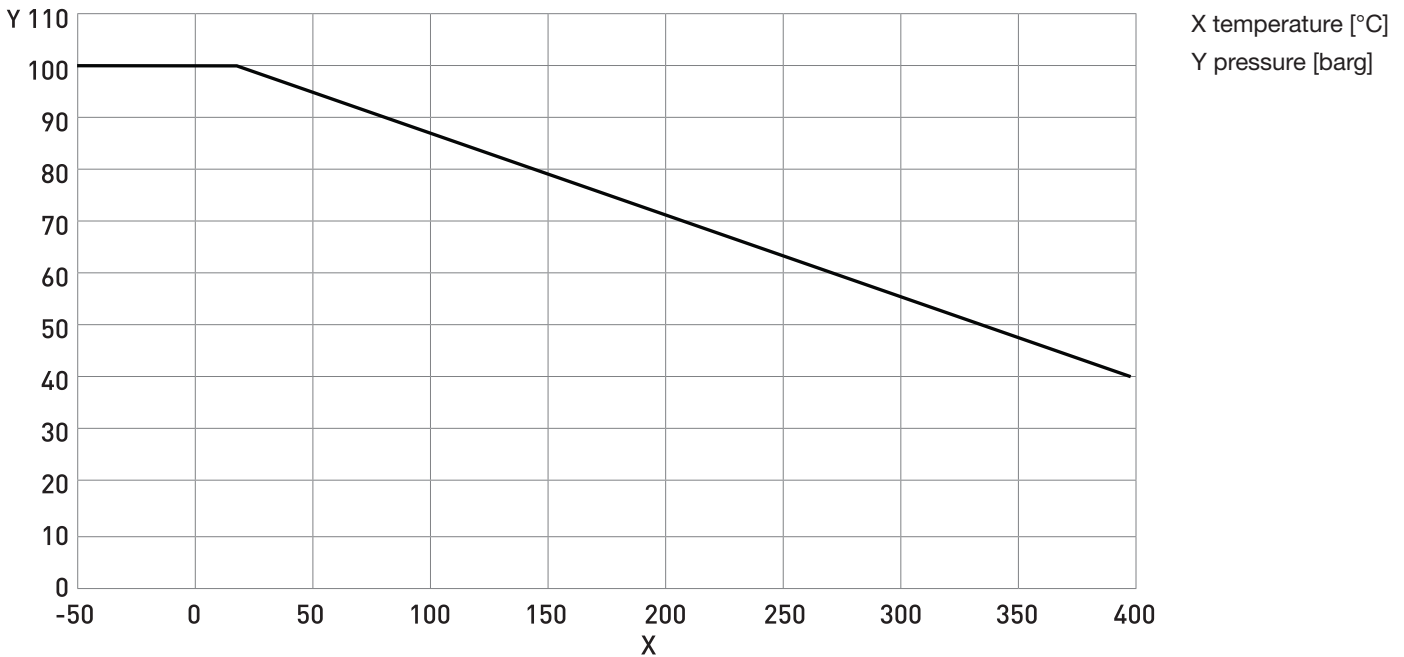

2. TECHNICAL DATA

2.3 Guidelines For Maximum Operating Pressure

Standard Temperature Range

Pressure / temperature de-rating (imperial) for meters with SS 31803 and Hastelloy® C22

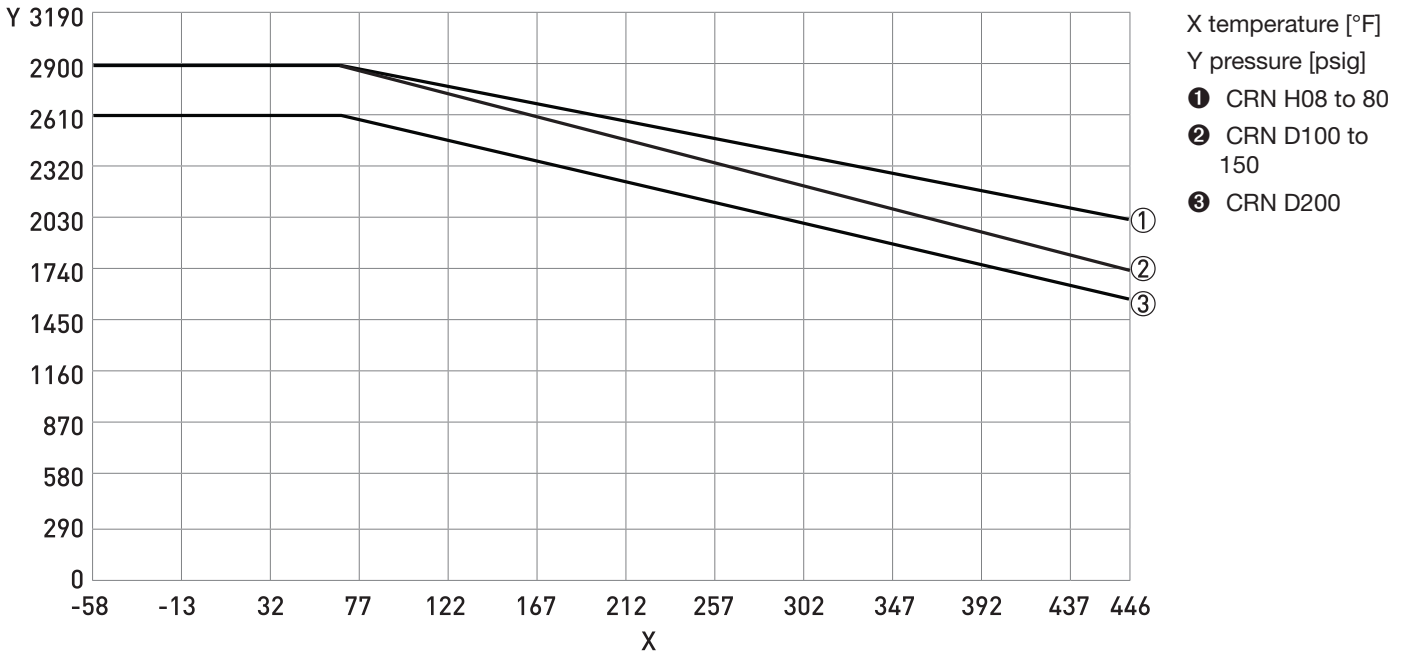

Pressure / temperature de-rating (metric) for meters with SS 31803 and Hastelloy® C22

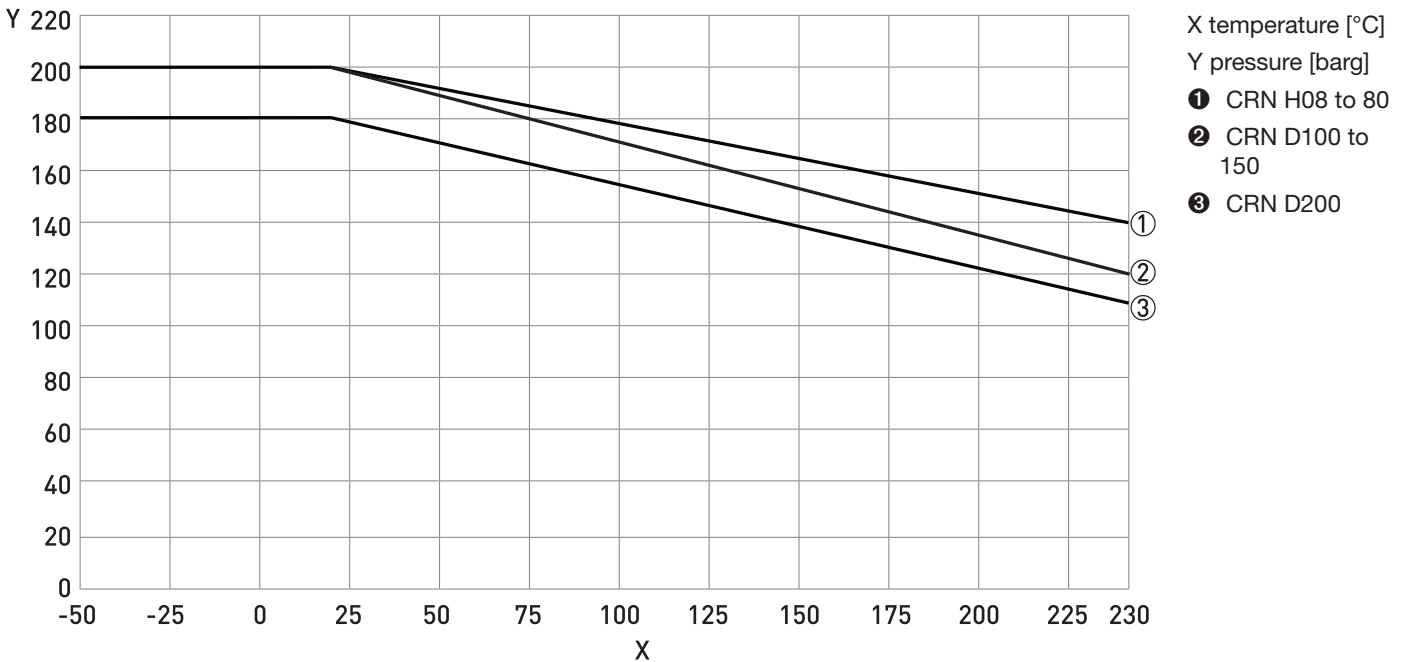

2. TECHNICAL DATA

2.3 Guidelines For Maximum Operating Pressure

Cryogenic Temperature Range

Pressure / temperature de-rating (imperial) for meters with SS 316 measuring tubes

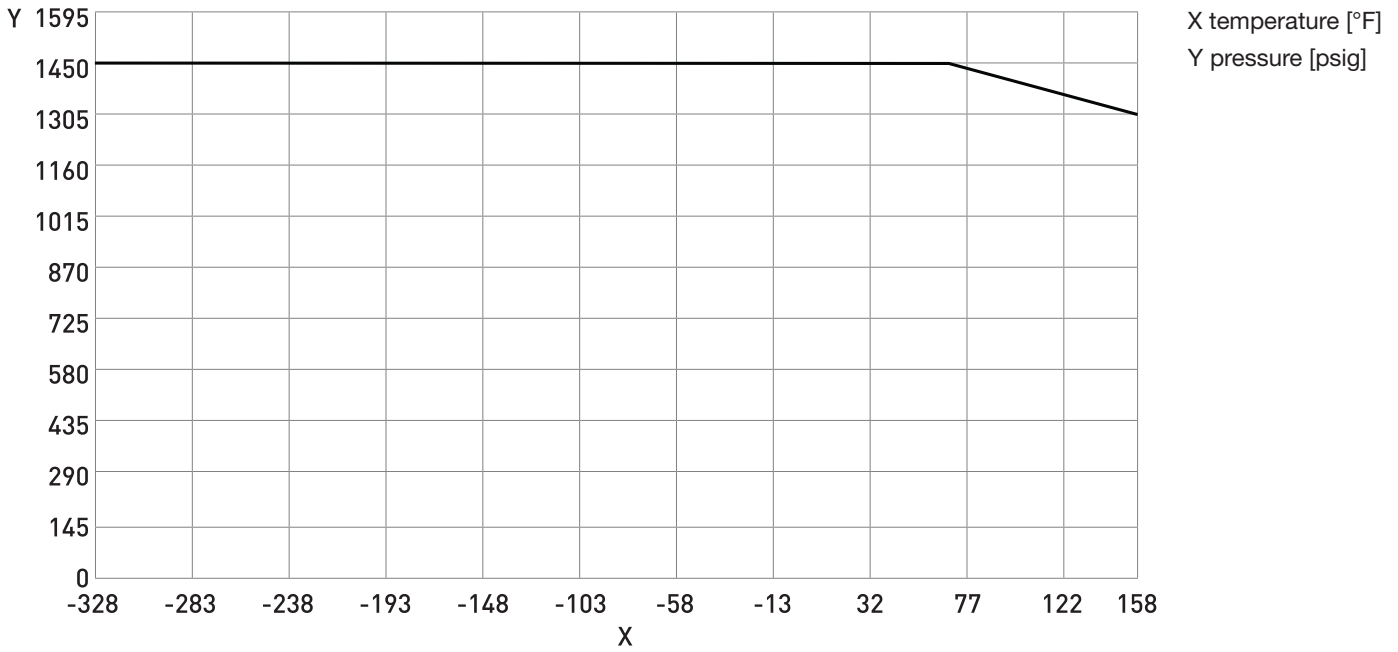

Pressure / temperature de-rating (metric) for meters with SS 316

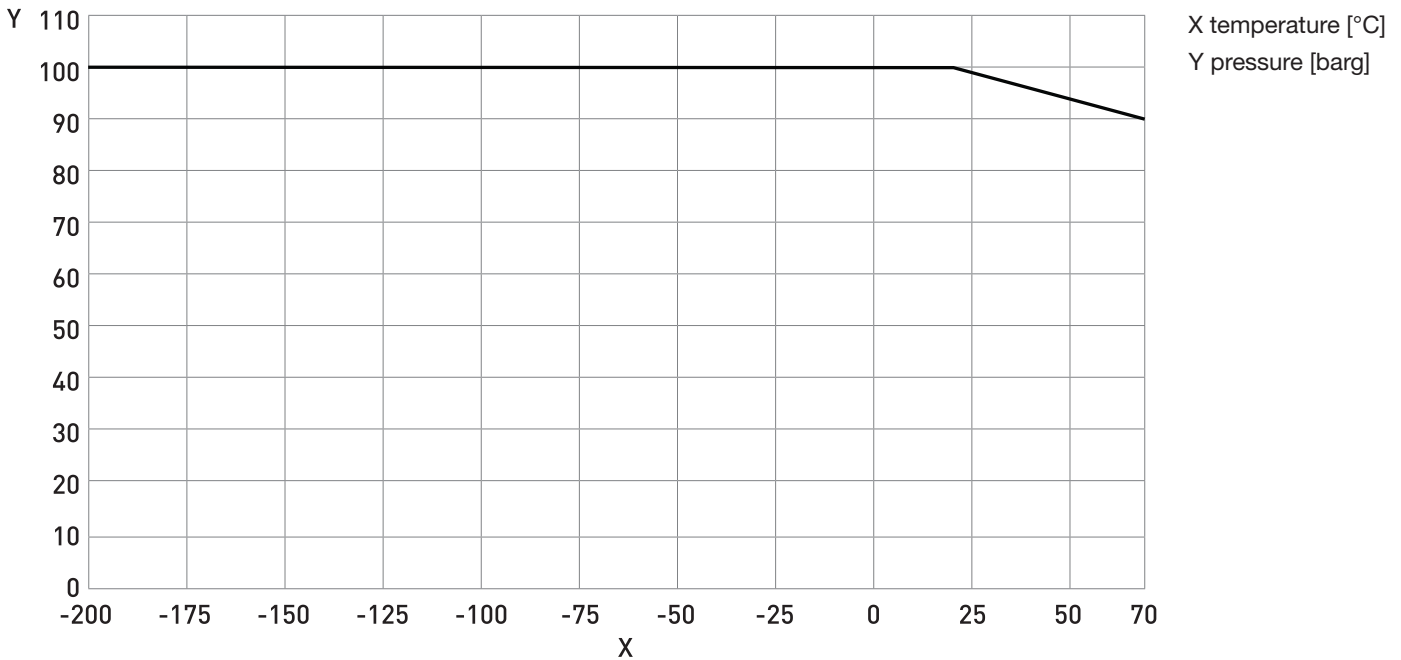

2. TECHNICAL DATA

2.3 Guidelines For Maximum Operating Pressure

Flanges

- ASME flange ratings are based on ASME B16.5 2003 table 2 material group 2.2
- DIN flange ratings are based on EN 1092-1 2007 table G.4.1 material group 14EO
- JIS flange ratings are based on JIS 2220: 2001 table 1 division 1 material group 022a
- JIS 10K flanges are limited to a maximum temperature of 572°F / 300°C

Notes

- The maximum operating pressure will be either the flange rating or the measuring tube rating, WHICHEVER IS LOWER!
- The manufacturer recommends that the seals are replaced at regular intervals. This will maintain the hygienic integrity of the connection.

2.4 Dimensions and Weights

2.4.1 Flanged Versions Meter Weights

	lbs / kg									
	S08	S10	S15	S25	S50	S80	S100	S150	S200	S250
Aluminum (compact)	20.5 / 9.3	22.3 / 10.1	28.4 / 12.9	51.8 / 23.5	64.8 / 29.4	129.8 / 58.9	207.9 / 94.3	426.8 / 193.6	978 / 443.6	2008.8 / 911.2
Stainless Steel (compact)	33.5 / 15.2	35.3 / 16	41.4 / 18.8	64.8 / 29.4	77.8 / 35.3	142.9 / 64.8	220.9 / 100.2	440.7 / 199.5	991 / 449.5	2021.9 / 917.1
Aluminum (remot)	12.8 / 5.8	14.5 / 6.6	20.7 / 9.4	43.9 / 19.9	57.1 / 25.9	122.1 / 55.4	200.2 / 90.8	419.1 / 190.1	970 / 440	2001 / 907.6
Stainless Steel (remote)	14.55 / 6.6	16.1 / 7.3	22.5 / 10.2	45.6 / 20.7	58.6 / 26.6	123.7 / 56.1	201.7 / 91.5	422.2 / 191.5	971.8 / 440.8	2002.7 / 908.4
Heating jacket add	6.8 / 3.1		9.9 / 4.5	15.4 / 7	17.4 / 7.9	28 / 12.7	34.6 / 15.7	60.8 / 27.6	N/A	

The weights shown are for meters fitted with PN40 flanges. Smaller or larger flange sizes will affect the overall weight. For further information, please contact the manufacturer.

2. TECHNICAL DATA

2.4 Dimensions and Weights

Meter Dimensions

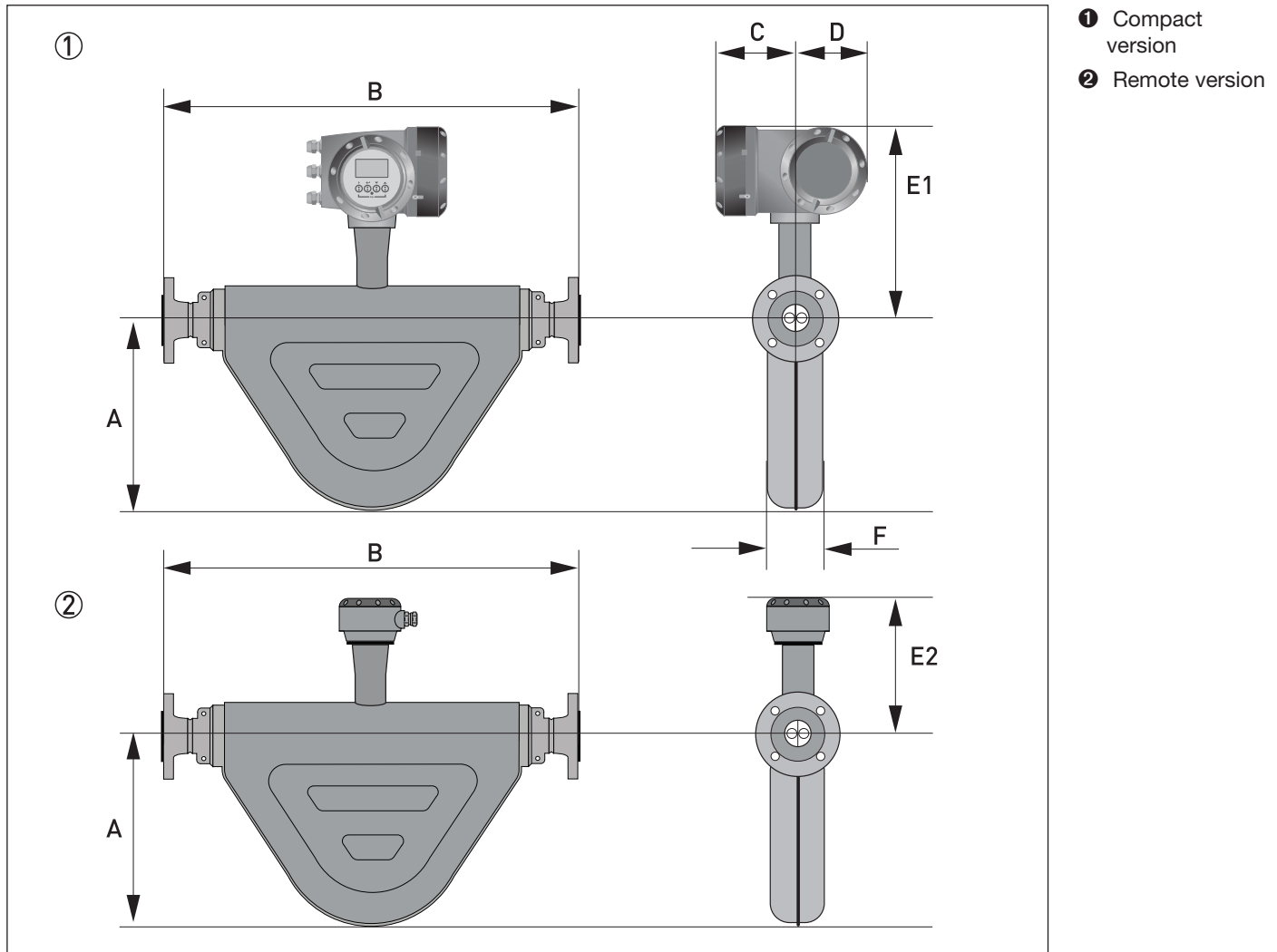

General Dimensions

	inches / millimeters									
	S08	S10	S15	S25	S50	S80	S100	S150	S200	S250
A ± 0.11 / ± 3	6.14 / 156		7.3 / 186	11.1 / 282	12.8 / 326	16.2 / 411	21.5 / 547	21.8 / 555	26.6 / 675	31.7 / 805
C	4.9 / 123.5									
D	5.4v									
E1 ± 0.12 / ± 3 (compact)	14.8 / 375	14.8 / 376	15.5 / 393		16.8 / 428	17.9 / 455	18.9 / 480	20.5 / 522	23.5 / 598	
E2 ± 0.12 / ± 3 (remote 482°F / 250°C)	11.6 / 295	11.6 / 296	12.4 / 316		13.7 / 348	14.8 / 375	15.7 / 400	17.4 / 442	20.4 / 518	
E2 ± 0.12 / ± 3 (remote 752°F / 400°C)	13.2 / 335	13.2 / 336	13.9 / 353		15.3 / 388	16.3 / 415	17.3 / 440	19 / 482	22 / 558	
F ± 0.08 / ± 2	3.2 / 81			4.6 / 118	5.1 / 130	7.4 / 188	9.6 / 243	10.8 / 275	14 / 355	20 / 508

2. TECHNICAL DATA

2.4 Dimensions and Weights

Dimension B For Meters With Stainless Steel Measuring Tubes

	inches (±0.2) / millimeters (±5)									
	S08	S10	S15	S25	S50	S80	S100	S150	S200	S250
ASME 150										
½"	14.2 / 361	14.7 / 373	20.9 / 530	-	-	-	-	-	-	-
¾"	-	-	21.2 / 540	-	-	-	-	-	-	-
1"	-	-	21.5 / 546	24.9 / 632	-	-	-	-	-	-
1½"	-	-	-	25.3 / 644	29.2 / 743	-	-	-	-	-
2"	-	-	-	-	29.4 / 747	36.5 / 926	-	-	-	-
3"	-	-	-	-	-	37 / 939	39.8 / 1010	-	-	-
4"	-	-	-	-	-	-	40.2 / 1022	47.3 / 1202	-	-
6"	-	-	-	-	-	-	-	48.3 / 1228	64.6 / 1640	-
8"	-	-	-	-	-	-	-	-	65.6 / 1666	-
10"	-	-	-	-	-	-	-	-	-	81.6 / 2074
12"	-	-	-	-	-	-	-	-	-	82.7 / 2100
ASME / 300										
½"	14.6 / 371	15.1 / 383	21.2 / 540	-	-	-	-	-	-	-
¾"	-	-	21.6 / 550	-	-	-	-	-	-	-
1"	-	-	22 / 558	25.3 / 644	-	-	-	-	-	-
1½"	-	-	-	25.9 / 658	29.8 / 757	-	-	-	-	-
2"	-	-	-	-	30 / 759	37 / 939	-	-	-	-
3"	-	-	-	-	-	37.7 / 957	40.5 / 1028	-	-	-
4"	-	-	-	-	-	-	41 / 1042	48.1 / 1222	-	-
6"	-	-	-	-	-	-	-	49 / 1246	65.3 / 1658	-
8"	-	-	-	-	-	-	-	-	66.4 / 1686	-
10"	-	-	-	-	-	-	-	-	-	82.9 / 2106
12"	-	-	-	-	-	-	-	-	-	83.9 / 2132
ASME / 600										
½"	15.1 / 383	15.5 / 395	21.7 / 552	-	-	-	-	-	-	-
¾"	-	-	22.1 / 562	-	-	-	-	-	-	-
1"	-	-	22.5 / 572	25.9 / 658	-	-	-	-	-	-
1½"	-	-	-	26.5 / 674	30.4 / 773	-	-	-	-	-
2"	-	-	-	-	30.7 / 779	37.7 / 959	-	-	-	-
3"	-	-	-	-	-	38.5 / 977	41.2 / 1048	-	-	-
4"	-	-	-	-	-	-	42.8 / 1086	49.8 / 1266	-	-
6"	-	-	-	-	-	-	-	51.1 / 1298	67.3 / 1710	-
8"	-	-	-	-	-	-	-	-	68.6 / 1742	-
10"	-	-	-	-	-	-	-	-	-	86 / 2186
12"	-	-	-	-	-	-	-	-	-	86.4 / 2194

2. TECHNICAL DATA

2.4 Dimensions and Weights

Dimension B For Meters With Stainless Steel Measuring Tubes, continued

	inches (±0.2) / millimeters (±5)									
	S08	S10	S15	S25	S50	S80	S100	S150	S200	S250
PN16										
DN80	-	-	-	-	-	-	38.2 / 970	-	-	-
DN100	-	-	-	-	-	-	39.3 / 1000	45.4 / 1154	-	-
DN150	-	-	-	-	-	-	-	47.2 / 1200	61.9 / 1572	-
DN200	-	-	-	-	-	-	-	-	62.4 / 1586	-
DN250	-	-	-	-	-	-	-	-	-	82.7 / 2100
DN300	-	-	-	-	-	-	-	-	-	79.8 / 2026
PN40										
DN10	13.2 / 335	13.7 / 347	-	-	-	-	-	-	-	-
DN15	13.4 / 341	13.9 / 353	20.1 / 510	-	-	-	-	-	-	-
DN25	-	-	20.2 / 514	23.6 / 600	-	-	-	-	-	-
DN40	-	-	-	24 / 610	27.9 / 709	-	-	-	-	-
DN50	-	-	-	-	28.1 / 715	35.2 / 895	-	-	-	-
DN80	-	-	-	-	-	36 / 915	38.8 / 986	-	-	-
DN100	-	-	-	-	-	-	39.4 / 1000	46.4 / 1180	-	-
DN150	-	-	-	-	-	-	-	47.2 / 1200	63.5 / 1612	-
DN200	-	-	-	-	-	-	-	-	64.5 / 1638	-
DN250	-	-	-	-	-	-	-	-	-	81.9 / 2080
DN300	-	-	-	-	-	-	-	-	-	82.7 / 2100
PN63										
DN50	-	-	-	-	29.2 / 743	36.3 / 923	-	-	-	-
DN80	-	-	-	-	-	37.1 / 943	39.9 / 1014	-	-	-
DN100	-	-	-	-	-	-	40.4 / 1026	47.5 / 1206	-	-
DN150	-	-	-	-	-	-	-	48.8 / 1240	65 / 1652	-
DN200	-	-	-	-	-	-	-	-	66.2 / 1682	-
DN250	-	-	-	-	-	-	-	-	-	83.5 / 2120
DN300	-	-	-	-	-	-	-	-	-	84.6 / 2150
PN100										
DN10	14 / 355	14.4 / 367	-	-	-	-	-	-	-	-
DN15	14 / 355	14.4 / 367	20.6 / 524	-	-	-	-	-	-	-
DN25	-	-	21.6 / 550	25 / 636	-	-	-	-	-	-
DN40	-	-	-	25.3 / 644	29.2 / 743	-	-	-	-	-
DN50	-	-	-	-	29.7 / 755	36.8 / 935	-	-	-	-
DN80	-	-	-	-	-	37.6 / 955	40.4 / 1026	-	-	-
DN100	-	-	-	-	-	-	41.3 / 1050	48.4 / 1230	-	-
DN150	-	-	-	-	-	-	-	50.4 / 1280	66.6 / 1692	-
DN200	-	-	-	-	-	-	-	-	67.8 / 1722	-
DN250	-	-	-	-	-	-	-	-	-	85.9 / 2184
DN300	-	-	-	-	-	-	-	-	-	87 / 2210

2. TECHNICAL DATA

2.4 Dimensions and Weights

Dimension B For Meters With Stainless Steel Measuring Tubes, continued

inches (± 0.2) / millimeters (± 5)

	S08	S10	S15	S25	S50	S80	S100	S150	S200	S250
JIS 10K										
50A	-	-	-	-	28.2 / 715	35.2 / 895	-	-	-	-
80A	-	-	-	-	-	36 / 915	38.8 / 986	-	-	-
100A	-	-	-	-	-	-	40.2 / 1022	47.3 / 1202	-	-
150A	-	-	-	-	-	-	-	47.3 / 1202	65 / 1652	-
200A	-	-	-	-	-	-	-	-	65.5 / 1666	-
250A	-	-	-	-	-	-	-	-	-	82.9 / 2106
300A	-	-	-	-	-	-	-	-	-	83.6 / 341
JIS / 20K										
10A	13.4 / 341	13.9 / 353	-	-	-	-	-	-	-	-
15A	13.4 / 341	13.9 / 353	20 / 510	-	-	-	-	-	-	-
25A	-	-	20.2 / 514	23.6 / 600	-	-	-	-	-	-
40A	-	-	-	24 / 610	27.9 / 709	-	-	-	-	-
50A	-	-	-	-	28.2 / 715	35.2 / 895	-	-	-	-
80A	-	-	-	-	-	36 / 915	38.8 / 986	-	-	-
100A	-	-	-	-	-	-	40.2 / 1022	48.8 / 1240	-	-
150A	-	-	-	-	-	-	-	48.8 / 1240	65 / 1652	-
200A	-	-	-	-	-	-	-	-	62.6 / 1666	-
250A	-	-	-	-	-	-	-	-	-	82.9 / 2106
300A	-	-	-	-	-	-	-	-	-	83.6 / 2124

2. TECHNICAL DATA

2.4 Dimensions and Weights

Dimension B For Meters With Hastelloy® And Stainless Steel (UNS S31803)									
inches (±0.2) / millimeters (±5)									
	H08	H10	H15	H25	H50	H80	D100	D150	D200
ASME 150									
½"	12.9 / 328	13.9 / 353	-	-	-	-	-	-	-
1"	-	-	20.1 / 510	-	-	-	-	-	-
1½"	-	-	-	23.6 / 600	-	-	-	-	-
2"	-	-	-	-	28.1 / 715	-	-	-	-
3"	-	-	-	-	-	36 / 915	-	-	-
ASME 300									
½"	12.9 / 328	13.9 / 353	-	-	-	-	-	-	-
1"	-	-	20.1 / 510	-	-	-	-	-	-
1½"	-	-	-	23.6 / 600	-	-	-	-	-
2"	-	-	-	-	28.1 / 715	-	-	-	-
3"	-	-	-	-	-	36	-	-	-
ASME 600									
½"	12.9 / 328	13.9 / 353	-	-	-	-	-	-	-
1"	-	-	20.1 / 510	-	-	-	-	-	-
1½"	-	-	-	23.6 / 600	-	-	-	-	-
2"	-	-	-	-	28.1 / 715	-	-	-	-
3"	-	-	-	-	-	36 / 915	-	-	-
ASME 900									
1½"	-	-	-	23.6 / 600	-	-	-	-	-
2"	-	-	-	-	28.1 / 715	-	-	-	-
3"	-	-	-	-	-	36 / 915	42.7 / 1086	-	-
4"	-	-	-	-	-	-	43.7 / 1112	50.9 / 1292	-
6"	-	-	-	-	-	-	-	52.7 / 1342	69 / 1754
8"	-	-	-	-	-	-	-	-	70.8 / 1798
ASME 1500									
½"	12.9 / 328	13.9 / 353	-	-	-	-	-	-	-
1"	-	-	20.1 / 510	-	-	-	-	-	-
1½"	-	-	-	23.6 / 600	-	-	-	-	-
2"	-	-	-	-	28.1 / 715	-	-	-	-
3"	-	-	-	-	-	36 / 915	44 / 1118	-	-
4"	-	-	-	-	-	-	44.5 / 1130	51.6 / 1310	-
6"	-	-	-	-	-	-	-	55.3 / 1406	71.6 / 1818
8"	-	-	-	-	-	-	-	-	74.8 / 1900

2. TECHNICAL DATA

2.4 Dimensions and Weights

Dimension B For Meters With Hastelloy® And Stainless Steel (UNS S31803), continued									
inches (±0.2) / millimeters (±5)									
	H08	H10	H15	H25	H50	H80	D100	D150	D200
PN40									
DN15	12.9 / 328	13.9 / 353	-	-	-	-	-	-	-
DN25	-	-	20.1 / 510	-	-	-	-	-	-
DN40	-	-	-	23.6 / 600	-	-	-	-	-
DN50	-	-	-	-	28.1 / 715	-	-	-	-
DN80	-	-	-	-	-	36 / 915	-	-	-
PN63									
DN50	-	-	-	-	28.1 / 715	-	-	-	-
DN80	-	-	-	-	-	36 / 915	-	-	-
PN100									
DN15	12.9 / 328	13.9 / 353	-	-	-	-	-	-	-
DN25	-	-	20.1 / 510	-	-	-	-	-	-
DN40	-	-	-	23.6 / 600	-	-	-	-	-
DN50	-	-	-	-	28.1 / 715	-	-	-	-
DN80	-	-	-	-	-	36 / 915	-	-	-
PN160									
DN15	12.9 / 328	13.9 / 353	-	-	-	-	-	-	-
DN25	-	-	20.1 / 510	-	-	-	-	-	-
DN40	-	-	-	23.6 / 600	-	-	-	-	-
DN50	-	-	-	-	28.1 / 715	-	-	-	-
DN80	-	-	-	-	-	36 / 915	41 / 1042	-	-
DN100	-	-	-	-	-	-	42.1 / 1070	49.2 / 1250	-
DN150	-	-	-	-	-	-	-	51.4 / 1306	67.6 / 1718
DN200	-	-	-	-	-	-	-	-	68.6 / 1742
JIS 10K									
50A	-	-	-	-	28.1 / 715	-	-	-	-
80A	-	-	-	-	-	36 / 915	-	-	-
JIS 20K									
15A	12.9 / 328	13.9 / 353	-	-	-	-	-	-	-
25A	-	-	20.1 / 510	-	-	-	-	-	-
40A	-	-	-	23.6 / 600	-	-	-	-	-
50A	-	-	-	-	28.1 / 715	-	-	-	-
80A	-	-	-	-	-	36 / 915	-	-	-

2. TECHNICAL DATA

2.4 Dimensions and Weights

2.4.3 Hygienic Versions

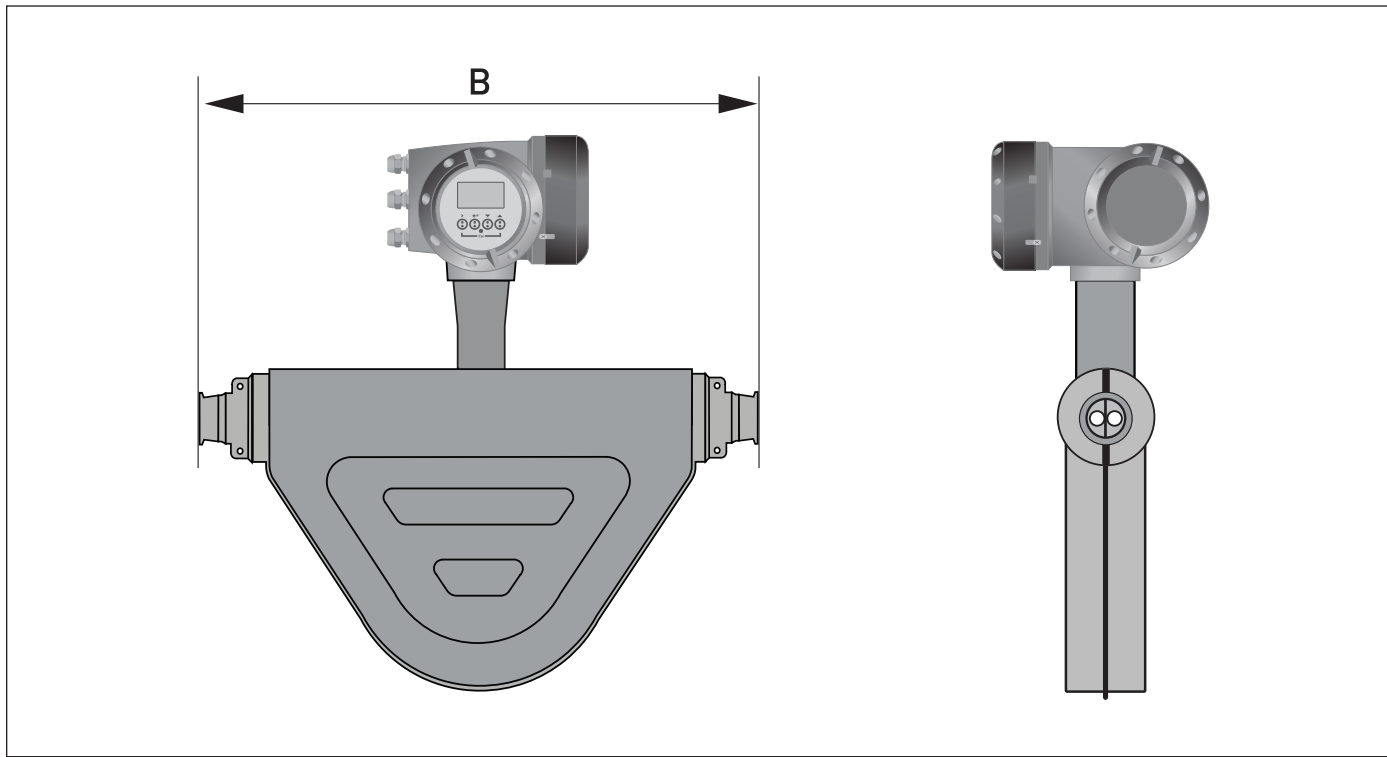

Dimension B For Meters With Stainless Steel Measuring Tubes

inches (± 0.2) / millimeters (± 5)

	S08	S10	S15	S25	S50	S80
Tri-clamp						
1/2"	12.1 / 308	12.6 / 320	-	-	-	-
1"	-	-	18.8 / 477	-	-	-
1 1/2"	-	-	-	22.2 / 563	-	-
2"	-	-	-	-	26 / 662	-
3"	-	-	-	-	-	33.1 / 842

2. TECHNICAL DATA

2.4 Dimensions and Weights

2.4.4 Heating Jacket Version

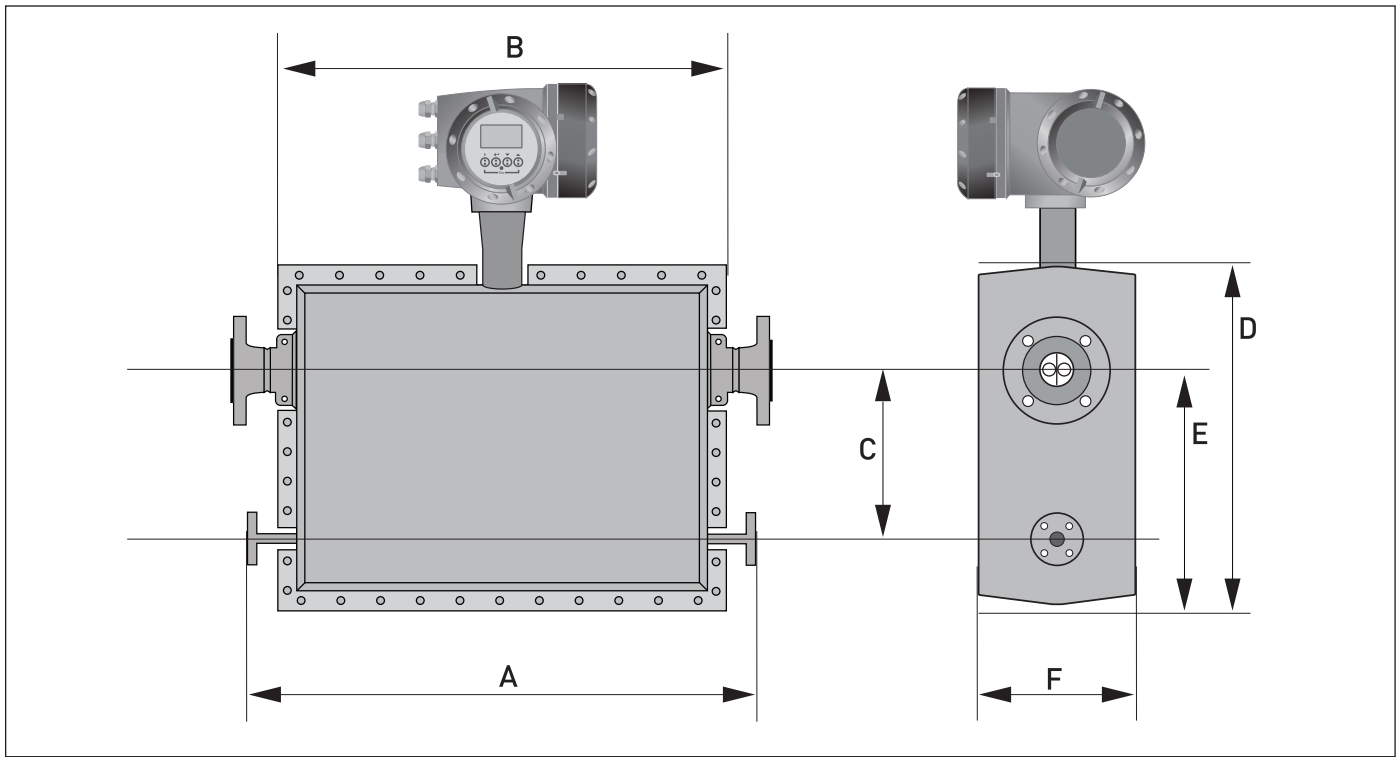

General Dimensions

inches (± 0.2) / millimeters (± 5)

	S08	S10	S15	S25	S50	S80	S100	S150	S200	S250
Heating connection size: PN40 DN15 or ASME 150 1/2"										
A $\pm 0.2 \pm 5.0$	17.1 / 435		23.2 / 590	27.2 / 692	28.1 / 715	35.1 / 891	37.6 / 956	44.8 / 44.8	TBA	TBA
B $\pm 0.12 \pm 3.0$	11.1 / 283		17.3 / 440	21.3 / 542	22.2 / 565	29.2 / 741	31.7 / 806	38.9 / 989	TBA	TBA
C $\pm 0.12 \pm 3.0$	3.9 / 100		5.1 / 130	8.3 / 210	9 / 230	12.6 / 320	13.4 / 340	17.7 / 450	TBA	TBA
D $\pm 0.12 \pm 3.0$	12.4 / 315		13.5 / 344	17.8 / 453	19.6 / 499	24.5 / 622	26.8 / 682	33.2 / 844	TBA	TBA
E $\pm 0.12 \pm 3.0$	7.8 / 198		8.7 / 221	12.4 / 316	14 / 356	17.7 / 451	19.1 / 486	24.3 / 617	TBA	TBA
F $\pm 0.12v$	9.1 / 232		8.9 / 226	10 / 254	10.5 / 266	12.7 / 322	14.6 / 372	16.8 / 428	TBA	TBA

2. TECHNICAL DATA

2.4 Dimensions and Weights

2.4.5 Purge Port Option

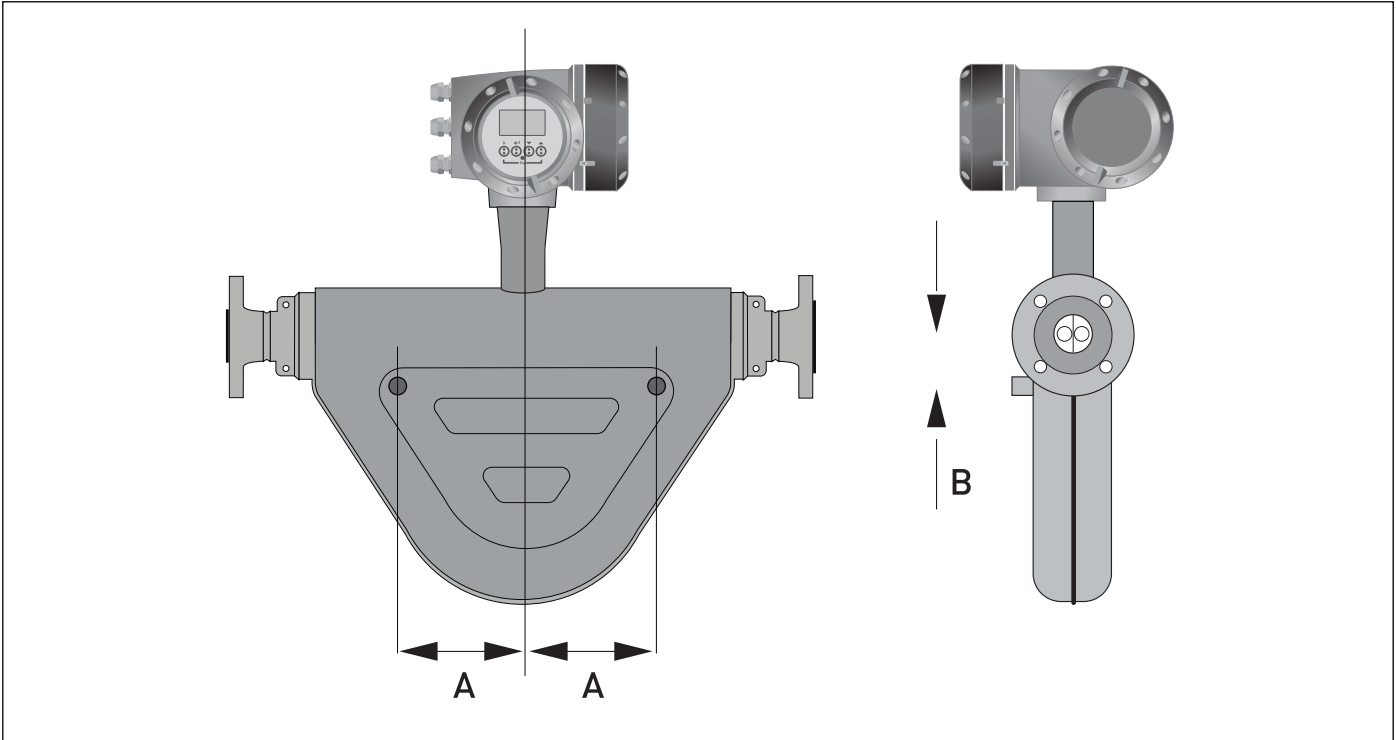

Dimensions

inches (±0.2) / millimeters (±5)										
	S08	S10	S15	S25	S50	S80	S100	S150	S200	S250
A	2.7 / 70		4.3 / 110	5.7 / 145	5.9 / 150	8.1 / 205	8.7 / 220	13.6 / 345	23.6 / 600	31.5 / 800
B	1.3 / 32		1.8 / 45	2.2 / 57	2.4 / 60	3.3 / 85		3.9 / 100	6.3 / 160	5.5 / 140

2. TECHNICAL DATA

2.4 Dimensions and Weights

2.4.6 Burst Disc Option

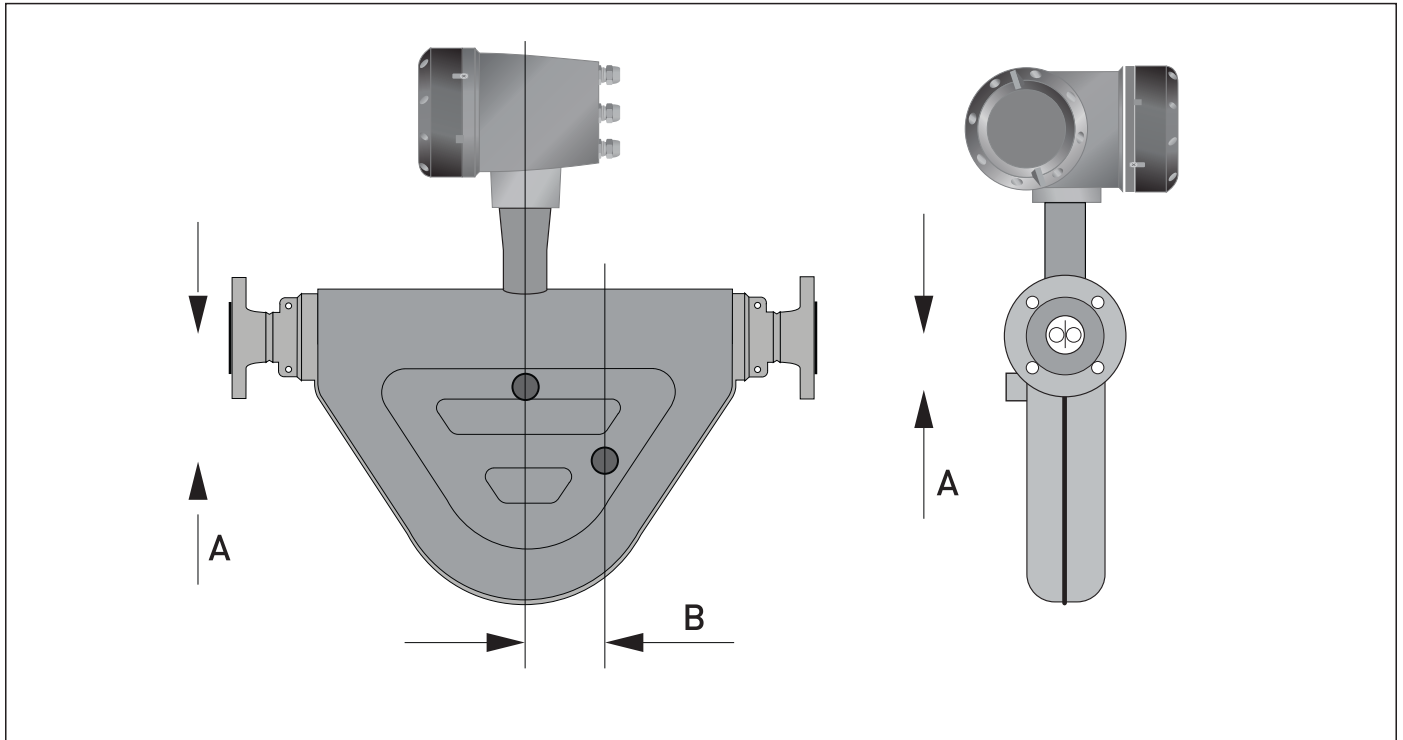

Dimensions

inches (±0.2) / millimeters (±5)										
	S08	S10	S15	S25	S50	S80	S100	S150	S200	S250
A	3.0 / 76		3.6 / 92	5.3 / 135	2.2 / 57	2.9 / 74		6.9 / 175	6.3 / 160	8.7 / 220
B	1.52 / 38.5		2.4 / 62	-	-	-		-	-	2.4 / 60

3. INSTALLATION

3.1 Intended Use

This mass flowmeter is designed for the direct measurement of mass flow rate, product density, and product temperature. Indirectly, it also enables the measurement of parameters like total mass,

concentration of dissolved substances, and the volume flow. For use in hazardous areas, special codes and regulations are also applicable and these are specified in a separate documentation.

3.2 Mounting Restrictions

3.2.1 General Installation Principles

There are no special installation requirements but you should note the following points:

- Support the weight of the meter as close to the meter body as possible.
- Mount the meter in such a way as to avoid the buildup of gas or liquid in the measuring tube.
- Straight runs on either side of the meter are not required.
- The use of reducers and other fittings at flanges, including flexible hoses, is allowed but you should take care to avoid cavitation.
- Avoid extreme pipe size reductions.
- Meters are not affected by crosstalk and can be mounted in series or in parallel.
- Avoid mounting the meter at the highest point in the pipeline where air / gas can collect.

3. INSTALLATION

3.2 Mounting Restrictions

3.2.1 General Installation Principles

Mounting Positions

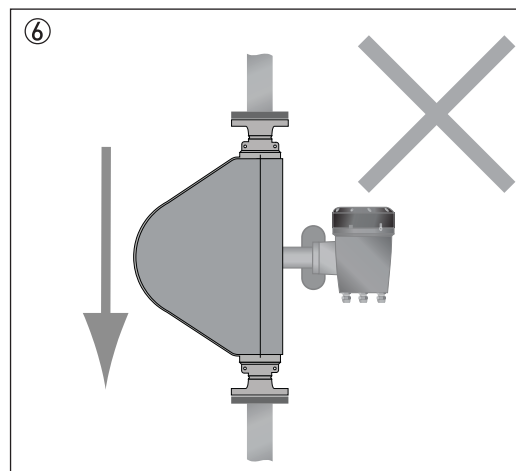
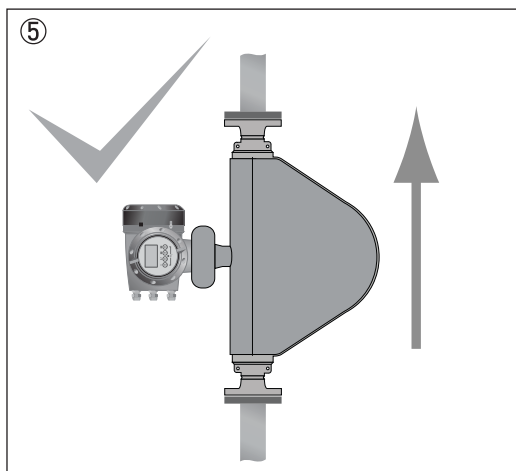
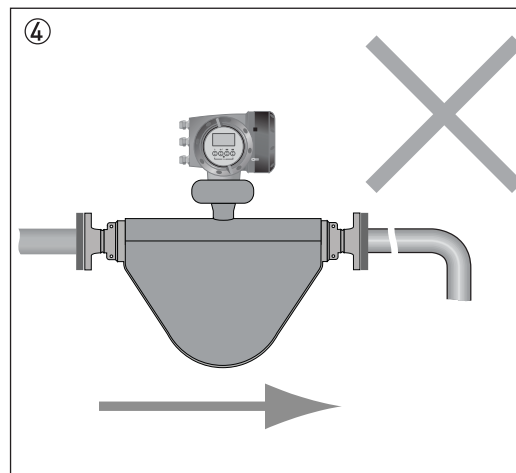
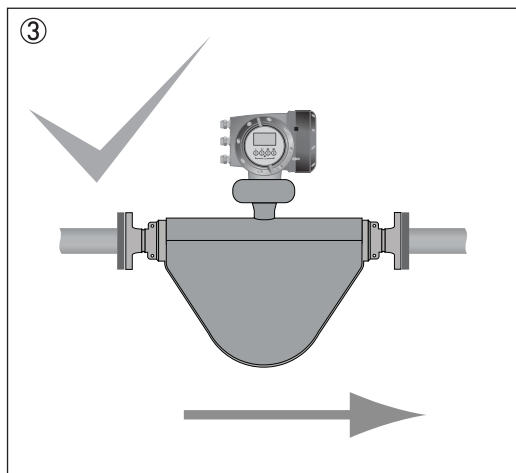
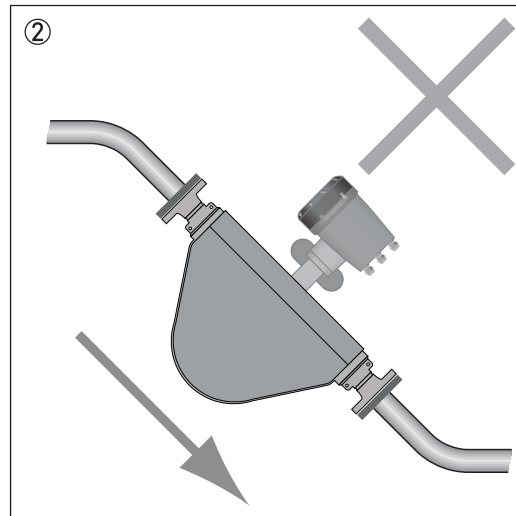
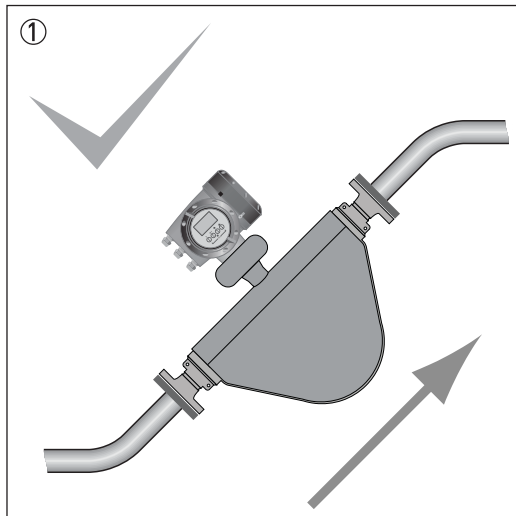

- ❶ The meter can be mounted at an angle, but it is recommended that the flow is uphill.
- ❷ Avoid mounting the meter with the flow running downhill because it can cause siphoning. If the meter has to be mounted with the flow running downhill, install an orifice plate or control valve downstream from the meter to maintain back-pressure.
- ❸ Horizontal mounting with flow running left to right.
- ❹ Avoid mounting meter with long vertical runs after the meter as it can cause cavitation. Where the installation includes a vertical run after the meter, install an orifice plate or control valve downstream to maintain backpressure.
- ❺ The meter can be mounted vertically, but it is recommended that the flow is uphill.
- ❻ Avoid mounting the meter vertically with the flow running downhill. This can cause siphoning. If the meter has to be installed this way, install an orifice plate or control valve downstream to maintain backpressure.

Comprehensive installation guidance is provided in the Handbook.



Архангельск (8182)63-90-72
Астана (7172)727-132
Астрахань (8512)99-46-04
Барнаул (3852)73-04-60
Белгород (4722)40-23-64
Брянск (4832)59-03-52
Владивосток (423)249-28-31
Волгоград (844)278-03-48
Вологда (8172)26-41-59
Воронеж (473)204-51-73
Екатеринбург (343)384-55-89
Иваново (4932)77-34-06
Ижевск (3412)26-03-58
Казань (843)206-01-48

Калининград (4012)72-03-81
Калуга (4842)92-23-67
Кемерово (3842)65-04-62
Киров (8332)68-02-04
Краснодар (861)203-40-90
Красноярск (391)204-63-61
Курск (4712)77-13-04
Липецк (4742)52-20-81
Магнитогорск (3519)55-03-13
Москва (495)268-04-70
Мурманск (8152)59-64-93
Набережные Челны (8552)20-53-41
Нижегород (831)429-08-12
Новокузнецк (3843)20-46-81

Новосибирск (383)227-86-73
Омск (3812)21-46-40
Орел (4862)44-53-42
Оренбург (3532)37-68-04
Пенза (8412)22-31-16
Пермь (342)205-81-47
Ростов-на-Дону (863)308-18-15
Рязань (4912)46-61-64
Самара (846)206-03-16
Санкт-Петербург (812)309-46-40
Саратов (845)249-38-78
Севастополь (8692)22-31-93
Симферополь (3652)67-13-56
Смоленск (4812)29-41-54

Сочи (862)225-72-31
Ставрополь (8652)20-65-13
Сургут (3462)77-98-35
Тверь (4822)63-31-35
Томск (3822)98-41-53
Тула (4872)74-02-29
Тюмень (3452)66-21-18
Ульяновск (8422)24-23-59
Уфа (347)229-48-12
Хабаровск (4212)92-98-04
Челябинск (351)202-03-61
Череповец (8202)49-02-64
Ярославль (4852)69-52-93