

Алматы (7273)495-231
Ангарск (3955)60-70-56
Архангельск (8182)63-90-72
Астрахань (8512)99-46-04
Барнаул (3852)73-04-60
Белгород (4722)40-23-64
Благовещенск (4162)22-76-07
Брянск (4832)59-03-52
Владивосток (423)249-28-31
Владикавказ (8672)28-90-48
Владимир (4922)49-43-18
Волгоград (844)278-03-48
Вологда (8172)26-41-59
Воронеж (473)204-51-73
Екатеринбург (343)384-55-89
Иваново (4932)77-34-06

Ижевск (3412)26-03-58
Иркутск (395)279-98-46
Казань (843)206-01-48
Калининград (4012)72-03-81
Калуга (4842)92-23-67
Кемерово (3842)65-04-62
Киров (8332)68-02-04
Коломна (4966)23-41-49
Кострома (4942)77-07-48
Краснодар (861)203-40-90
Красноярск (391)204-63-61
Курган (3522)50-90-47
Курск (4712)77-13-04
Липецк (4742)52-20-81
Магнитогорск (3519)55-03-13

Россия +7(495)268-04-70

Москва (495)268-04-70
Мурманск (8152)59-64-93
Набережные Челны (8552)20-53-41
Нижний Новгород (831)429-08-12
Новокузнецк (3843)20-46-81
Новосибирск (383)227-86-73
Ноябрьск (3496)41-32-12
Омск (3812)21-46-40
Орел (4862)44-53-42
Оренбург (3532)37-68-04
Пенза (8412)22-31-16
Пермь (342)205-81-47
Петрозаводск (8142)55-98-37
Псков (8112)59-10-37

Казахстан +7(7172)727-132

Ростов-на-Дону (863)308-18-15
Рязань (4912)46-61-64
Самара (846)206-03-16
Санкт-Петербург (812)309-46-40
Саранск (8342)22-96-24
Саратов (845)249-38-78
Севастополь (8692)22-31-93
Симферополь (3652)67-13-56
Смоленск (4812)29-41-54
Сочи (862)225-72-31
Ставрополь (8652)20-65-13
Сургут (3462)77-98-35
Сыктывкар (8212)25-95-17
Тамбов (4752)50-40-97

Киргизия +996(312)96-26-47

Тверь (4822)63-31-35
Тольятти (8482)63-91-07
Томск (3822)98-41-53
Тула (4872)33-79-87
Тюмень (3452)66-21-18
Улан-Удэ (3012)59-97-51
Ульяновск (8422)24-23-59
Уфа (347)229-48-12
Хабаровск (4212)92-98-04
Чебоксары (8352)28-53-07
Челябинск (351)202-03-61
Череповец (8202)49-02-64
Чита (3022)38-34-83
Якутск (4112)23-90-97
Ярославль (4852)69-52-93

crn@nt-rt.ru || <https://lcmeter.nt-rt.ru/>

Single Head Bulk Plant Air Eliminator with Optical Sensor Simple Bulk Plant Air Elimination

Benefits

- Easier installation
- Faster response time
- Less maintenance

Features

- Less piping
- Fewer moving parts
- No air check or differential valve required
- Optical sensor
- Low Mount Mechanical Air Eliminator
- Integral valve control with MultiLoad or LectroCount electronics
- Ideal for refined fuels offloading
- Designed to meet Class 1, Division 2 requirements

General Information

The Single Head Bulk Plant Air Eliminator with Optical Sensor is a new bulk plant air elimination solution that promises faster response times, quicker installations, and less maintenance than pneumatic-based mechanical air eliminators. This air eliminator is ideal for eliminating air from refined fuels applications where product is metered into storage from a truck-mounted pump.

The Single Head Bulk Plant Air Eliminator with Optical Sensor is the latest innovation in the four-decade long evolution of Liquid Controls' air eliminators. For years, Liquid Controls mechanical bulk plant air eliminators—in single and dual head configurations—have reliably removed entrained air from metering systems in high flow rate loading and offloading applications. Both configurations have a large tank where the air is allowed to separate from the liquid and a high mount air eliminator at the top of the tank that remove the air from the system. The dual head bulk plant air eliminator has an additional air eliminator mounted below the high mount air eliminator. The low mount air eliminator identifies and helps to remove large slugs of air that can sometimes overwhelm the high mount air eliminator.

The Single Head Bulk Plant Air Eliminator with Optical Sensor is a more advanced alternative to the dual head bulk plant air eliminator. Like the dual head bulk plant air eliminator, it uses a high mount air eliminator to remove air from the system. But instead of relying on a low mount mechanical air eliminator to identify large air slugs, it uses an optical sensor. When the optical sensor identifies a large air slug, it instantly signals an electronic preset or register (Toptech's MultiLoad presets or Liquid Controls' LectroCount registers). Upon receiving the signal from the optical sensor, the electronic device closes a downstream control valve, stopping the product flow, and the air slug is quickly vented through the high mount air eliminator.

The optical sensor responds to and eliminates air slugs faster than pneumatic-based mechanical air eliminators. Because the Single Head Bulk Plant Air Eliminator with Optical Sensor has no moving parts or piping requirements, installation times are shorter, maintenance concerns are reduced, and service life is extended.



Single Head Bulk Plant Air Eliminator with Optical Sensor



Single Head Bulk Plant Air Eliminator with Optical Sensor

Specifications

Sizes

3, 4, and 6"

Standard Endfittings

150# RF ANSI Flanged
Aluminum meters may require piping adaptation

Standard Material

Carbon Steel

Working Pressure

150 PSI

Temperature Range

-40 to 158° F (-40 to 70° C)

Air Elimination Rates

150 ft³/min at 8 psig or
88 ft³/min at 2 psig

Power Input - Optical Sensor

- 10.2 to 27.2 VDC
- 0.5 A maximum

Dimensions

FRONT VIEW

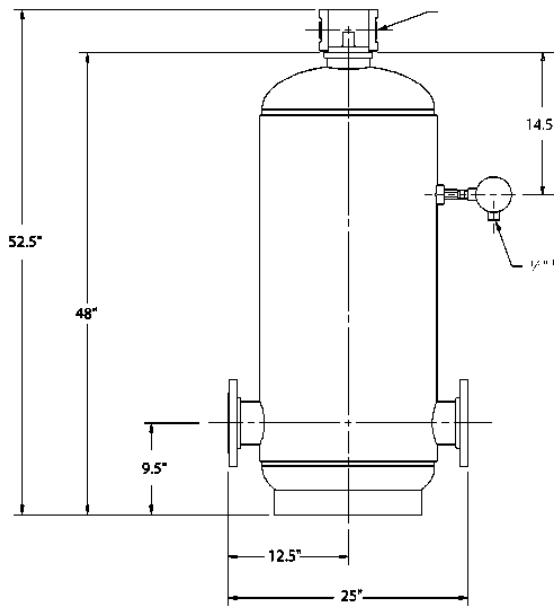

Dimensions of 4" model shown

Consult the factory when certified engineering drawings are required. Dimensions shown are not suitable for construction or modifications.

TOP VIEW

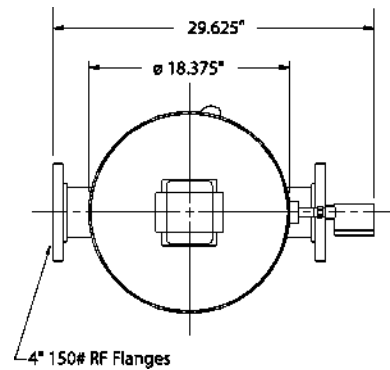

Part Numbers

A89511

3" 150# ANSI Flanged single head bulk plant air eliminator with optical sensor

A89551

4" 150# ANSI Flanged single head bulk plant air eliminator with optical sensor

A89571

6" 150# ANSI Flanged single head bulk plant air eliminator with optical sensor

Алматы (7273)495-231
Ангарск (3955)60-70-56
Архангельск (8182)63-90-72
Астрахань (8512)99-46-04
Барнаул (3852)73-04-60
Белгород (4722)40-23-64
Благовещенск (4162)22-76-07
Брянск (4832)59-03-52
Владивосток (423)249-28-31
Владикавказ (8672)28-90-48
Владимир (4922)49-43-18
Волгоград (844)278-03-48
Вологда (8172)26-41-59
Воронеж (473)204-51-73
Екатеринбург (343)384-55-89
Иваново (4932)77-34-06

Ижевск (3412)26-03-58
Иркутск (395)279-98-46
Казань (843)206-01-48
Калининград (4012)72-03-81
Калуга (4842)92-23-67
Кемерово (3842)65-04-62
Киров (8332)68-02-04
Коломна (4966)23-41-49
Кострома (4942)77-07-48
Краснодар (861)203-40-90
Красноярск (391)204-63-61
Курган (3522)50-90-47
Курск (4712)77-13-04
Липецк (4742)52-20-81
Магнитогорск (3519)55-03-13

Россия +7(495)268-04-70

Москва (495)268-04-70
Мурманск (8152)59-64-93
Набережные Челны (8552)20-53-41
Нижний Новгород (831)429-08-12
Новокузнецк (3843)20-46-81
Новосибирск (383)227-86-73
Ноябрьск (3496)41-32-12
Омск (3812)21-46-40
Орел (4862)44-53-42
Оренбург (3532)37-68-04
Пенза (8412)22-31-16
Пермь (342)205-81-47
Петрозаводск (8142)55-98-37
Псков (8112)59-10-37

Казахстан +7(7172)727-132

Ростов-на-Дону (863)308-18-15
Рязань (4912)46-61-64
Самара (846)206-03-16
Санкт-Петербург (812)309-46-40
Саранск (8342)22-96-24
Саратов (845)249-38-78
Севастополь (8692)22-31-93
Симферополь (3652)67-13-56
Смоленск (4812)29-41-54
Сочи (862)225-72-31
Ставрополь (8652)20-65-13
Сургут (3462)77-98-35
Сыктывкар (8212)25-95-17
Тамбов (4752)50-40-97

Киргизия +996(312)96-26-47

Тверь (4822)63-31-35
Тольятти (8482)63-91-07
Томск (3822)98-41-53
Тула (4872)33-79-87
Тюмень (3452)66-21-18
Улан-Удэ (3012)59-97-51
Ульяновск (8422)24-23-59
Уфа (347)229-48-12
Хабаровск (4212)92-98-04
Чебоксары (8352)28-53-07
Челябинск (351)202-03-61
Череповец (8202)49-02-64
Чита (3022)38-34-83
Якутск (4112)23-90-97
Ярославль (4852)69-52-93