

Алматы (7273)495-231  
Ангарск (3955)60-70-56  
Архангельск (8182)63-90-72  
Астрахань (8512)99-46-04  
Барнаул (3852)73-04-60  
Белгород (4722)40-23-64  
Благовещенск (4162)22-76-07  
Брянск (4832)59-03-52  
Владивосток (423)249-28-31  
Владикавказ (8672)28-90-48  
Владимир (4922)49-43-18  
Волгоград (844)278-03-48  
Вологда (8172)26-41-59  
Воронеж (473)204-51-73  
Екатеринбург (343)384-55-89  
Иваново (4932)77-34-06

Ижевск (3412)26-03-58  
Иркутск (395)279-98-46  
Казань (843)206-01-48  
Калининград (4012)72-03-81  
Калуга (4842)92-23-67  
Кемерово (3842)65-04-62  
Киров (8332)68-02-04  
Коломна (4966)23-41-49  
Кострома (4942)77-07-48  
Краснодар (861)203-40-90  
Красноярск (391)204-63-61  
Курган (3522)50-90-47  
Курск (4712)77-13-04  
Липецк (4742)52-20-81  
Магнитогорск (3519)55-03-13

Россия +7(495)268-04-70

Москва (495)268-04-70  
Мурманск (8152)59-64-93  
Набережные Челны (8552)20-53-41  
Нижний Новгород (831)429-08-12  
Новокузнецк (3843)20-46-81  
Новосибирск (383)227-86-73  
Ноябрьск (3496)41-32-12  
Омск (3812)21-46-40  
Орел (4862)44-53-42  
Оренбург (3532)37-68-04  
Пенза (8412)22-31-16  
Пермь (342)205-81-47  
Петрозаводск (8142)55-98-37  
Псков (8112)59-10-37

Казахстан +7(7172)727-132

Ростов-на-Дону (863)308-18-15  
Рязань (4912)46-61-64  
Самара (846)206-03-16  
Санкт-Петербург (812)309-46-40  
Саранск (8342)22-96-24  
Саратов (845)249-38-78  
Севастополь (8692)22-31-93  
Симферополь (3652)67-13-56  
Смоленск (4812)29-41-54  
Сочи (862)225-72-31  
Ставрополь (8652)20-65-13  
Сургут (3462)77-98-35  
Сыктывкар (8212)25-95-17  
Тамбов (4752)50-40-97

Киргизия +996(312)96-26-47

Тверь (4822)63-31-35  
Тольятти (8482)63-91-07  
Томск (3822)98-41-53  
Тула (4872)33-79-87  
Тюмень (3452)66-21-18  
Улан-Удэ (3012)59-97-51  
Ульяновск (8422)24-23-59  
Уфа (347)229-48-12  
Хабаровск (4212)92-98-04  
Чебоксары (8352)28-53-07  
Челябинск (351)202-03-61  
Череповец (8202)49-02-64  
Чита (3022)38-34-83  
Якутск (4112)23-90-97  
Ярославль (4852)69-52-93

crn@nt-rt.ru || <https://lcmeter.nt-rt.ru/>

## EP Series

### Electro-Pneumatic Preset Valve

### Installation and Parts



**LIQUID CONTROLS™**  
An IDEX Energy & Fuels Business

# TABLE OF CONTENTS

<b>1.</b>	<b>SPECIFICATIONS</b>	<b>4</b>
<b>2.GENERAL</b>	<b>INFORMATION</b>	<b>4</b>
<b>3.</b>	<b>OPERATION</b>	<b>5</b>
<b>4. INSTALLATION</b>		
4.1 New Installations .....		6
4.2 Retrofit Installations.....		7
4.3 Valve Orientation .....		7
4.4 Dwell Flow Adjustment.....		8
4.5 Full Flow Adjustment.....		8
<b>5.DIMENSIONAL</b>	<b>DRAWINGS</b>	<b>9</b>
<b>6.SPARE</b>	<b>PARTS</b>	<b>12</b>

## WARNING

Before using this product, read and understand the instructions.

Save these instructions for future reference.

All work must be performed by qualified personnel trained in the proper application, installation, and maintenance of equipment and/or systems in accordance with all applicable codes and ordinances.

Failure to follow the instructions set forth in this publication could result in property damage, personal injury, or death from fire and/or explosion, or other hazards that may be associated with this type of equipment.



## WARNING

Before disassembly of any meter or accessory component:

ALL INTERNAL PRESSURES MUST BE RELIEVED AND ALL LIQUID DRAINED FROM THE SYSTEM IN ACCORDANCE WITH ALL APPLICABLE PROCEDURES.

- Pressure must be 0 (zero) psi.
- Close all liquid and vapor lines between the meter and liquid source.

Failure to follow this warning could result in property damage, personal injury, or death from fire and/or explosion, or other hazards that may be associated with this type of equipment.



## 1. SPECIFICATIONS

### Environmental Rating

Meets ATEX 94/9/EC Requirements

### Safety

Meets PED 97/23/EC Requirements

### Materials of Construction

Class 1

Valve Body: Aluminum

Internal Seals: Viton (Teflon for EP30)

External Seals: Buna

### Temperature Rating

-4° to 158°F (-20° to 70°C)

### Pressure Rating

Maximum non-shock working pressure: 150 PSI (10.5 bar)

### Maximum Flow Rate

EP7: 132 GPM (500 L/min)

EP15: 264 GPM (1000 L/min)

EP30: 449 GPM (1700 L/min)

### Viscosity Range

30 to 20,000 SSU\*

\*Consult factory for higher viscosity liquid applications

### Products

Class 1 Refined Fuels (gasoline, fuel oils, diesel fuel, kerosene, ethylene glycol, and lube oils)

### Two Stage Operation

Reduced flow adjustable from 0 to 15% of full flow

### Pneumatic Solenoids-EP7 only

(Available mounted to valve, or sold separately) 502137

Operation: 3 way, normally closed

Voltage: 12VDC

Operating Pressure Range: 50-145 psi regulated air

### Pneumatic Solenoids-EP15/30 only

(Sold separately) 84035

Operation: 3 way, normally closed

Voltage: 12VDC

Operating Pressure Range: 50-145 psi regulated air

## 2. GENERAL INFORMATION

The Liquid Controls EP family of Electro-Pneumatic, 2-stage, preset valves are designed to control the flow of refined petroleum products including: diesel fuel, gasoline, fuel oils, kerosene, ethylene glycol, and lube oils.

These valves can be integrated into a complete metering system containing an M7, M10, M15, M25, M30, or M40 Class 1 meter with electronic registration.

Due to the less restrictive design, EP Valves provide the benefit of reduced pressure drop and higher potential flow rates, especially when handling higher-viscosity products.

These valves can be installed directly on the meter outlet in a variety of orientations to allow for a compact installation.

### 3. OPERATION

#### Two Stage Closure

The EP series of valves require two solenoids (sold separately) to control the two state closure of the valve. During full flow, solenoid valve one S1 opens to allow compressed air into the high flow chamber. During dwell flow, S1 closes and S2 opens. With LCR Electronic Registers, at the end of a preset delivery, S2 will close at a learned time, so that the exact desired volume is dispensed. Shutting off during this dwell flow also reduces the risk of hydraulic shock.

#### Valve Closed

When no air is supplied to the high flow or low flow chambers, piston "a", attached to shaft "b" presses on gasket "c" due to the action of spring "d". When closed, the fluid pressure contributes to the sealing force of the spring.

#### Full Flow

When the high flow chamber is supplied with air, shaft "b" lifts until making contact with head "e", lifting shutter "a" to its maximum position.

#### Reduced (Dwell) Flow

When air shut off from the high flow chamber and supplied to the low flow chamber, piston "f" lifts until contacting head "g", lifting the piston "a" by an amount determined by the position of stop nut "h". This nut can be adjusted to allow for 0-15% of full flow.

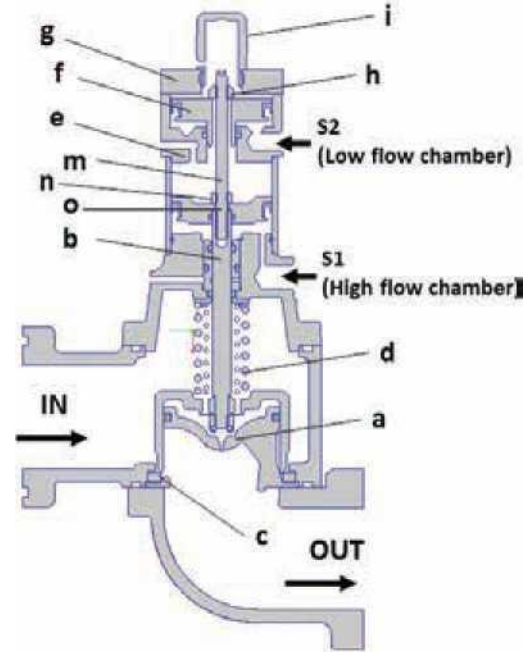

Operating States			
	Full Flow	Reduced Flow	Zero Flow
Supplied with air? (yes/no)			
High flow chamber (S1)	Yes	No	No
Low flow chamber (S2)	No	Yes	No

#### Chamber (S2)

#### S1 Close

LectroCount LCR & LectroCount LCR-I™	Solenoid 1	Solenoid ON	11 11
	Solenoid OFF		Solenoid OFF 11
Solenoid 2	Solenoid OFF		Solenoid ON ' ' Solenoid OFF
			11 11
		Full Flow	11 Solenoid ZERO Shutoff is Self Adjusting
Product Flow Through the Meter		No Flow	11 ] No Flow

## 4. INSTALLATION

### 4.1 New Installations

#### 4.1.1 EP7

When ordered with a new meter, the EP7 Series valves are supplied mounted to the outlet side of the meter. Four standard orientations are available: Outlet Inline, Outlet Up, Outlet Front, or Outlet Rear, as shown at right.

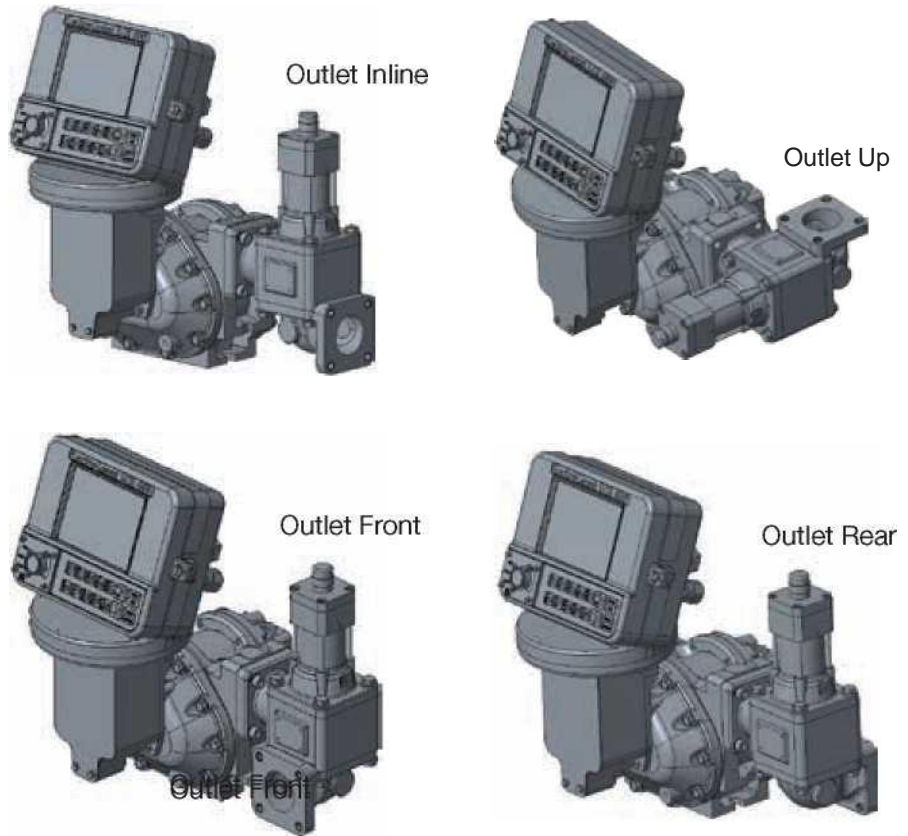

When ordered with pneumatic solenoids mounted (A26261), the valve will come pre-plumbed to the solenoids, and the solenoids pre-wired to the LCR. Air pressure, regulated to between 50 and 125psi (3.5 and 8.6 bar) must be supplied to the valve through the elbow beneath the solenoids, as shown at right. It is strongly recommended that an air dryer is incorporated in the upstream system.

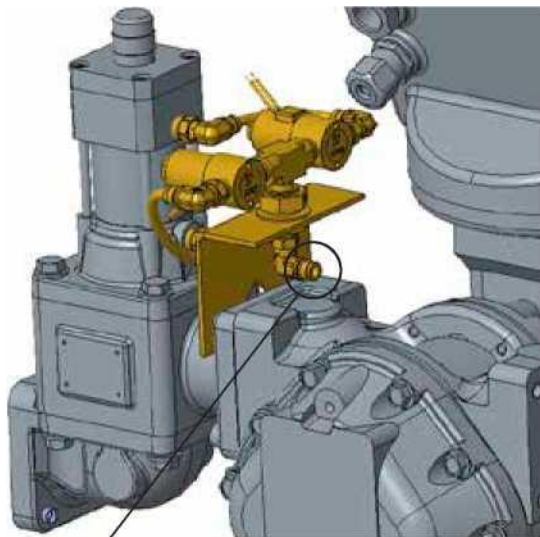

1/4" O.D. Air Tubing

If the pneumatic solenoid assembly is ordered separately (502137), it must be installed such that the air line connects the S1 solenoid to the bottom port of the valve and S2 to the top port. The cables should be wired into the LCR according to the diagram below.

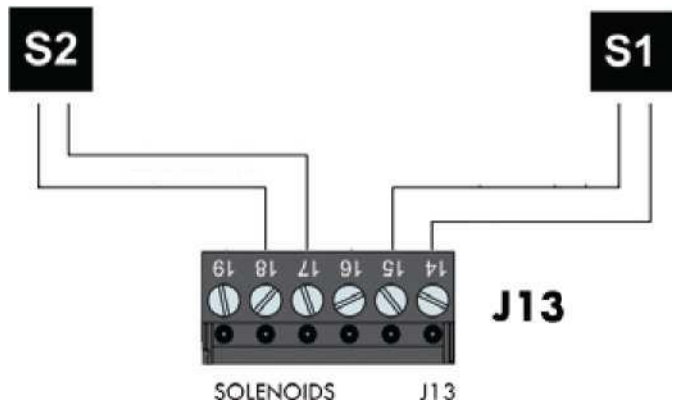

# 4. INSTALLATION

## 4.1 New Installations

### 4.1.2 EP15 and EP30

When ordered with a new meter, the EP15 and EP30 Series valves are supplied mounted to the outlet side of the meter. Three standard orientations are available: Outlet Down, Outlet Front, or Outlet Rear, as shown below.



Solenoid Kit 84035 is available for purchase and can be used for both the EP15 and EP30. It contains two normally closed (NC) solenoids and two cable assemblies. The cables should be wired according to the diagram at right.

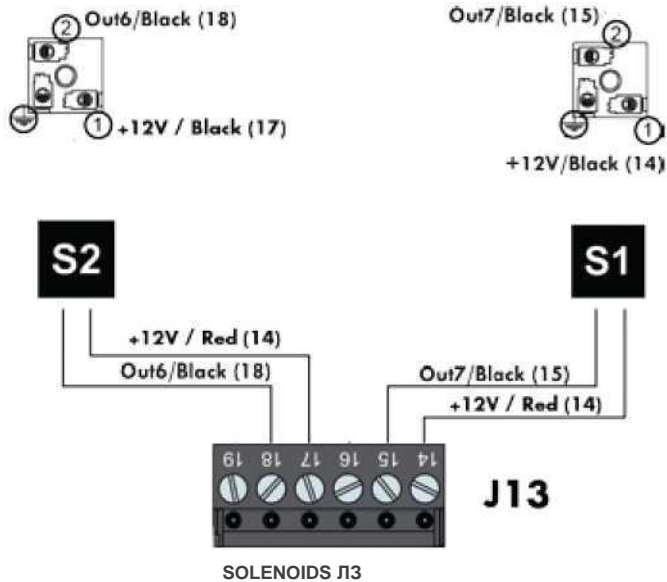

The solenoid-operated valves are grounded through the component they are mounted on.

On the valve are two 1/4" NPT ports. It is recommended that the solenoids be mounted in a protected location within 18" of the LCR, as this is the length of the cables provided. Typical NPT fittings and air lines may be used to route air to solenoids and valves. All components used should be able to withstand the maximum air pressure of the system. The air supply should be regulated between 50 and 150 psi (3.5 and 10.3 bar). The air supply should be connected to the inlet port "P" of each solenoid and outlet port "A" should route to each port on the valve. Solenoids in the kit have female 3/8" NPT ports. If an exhaust restrictor is used on one of the solenoids, it should be on S2 (closer to top of valve).



## 4. INSTALLATION

### 4.1 New Installations

#### 4.1.3 Initial Settings

The dwell time will need to be initially set via the LCR software. To set the initial S1 close / S2 open time in the Product Calibration Menu, refer to the operation manual of the appropriate LCR register. While this value is automatically “learned” by the LCR, recommended initial settings are:

EP7: 3 gallons

EP15: 10 gallons

EP30: 40 gallons

Optimal settings may vary by application. Consult the factory for settings on high viscosity products.

### 4.2 Retrofit Installations

After the internal pressure is relieved from the system, and the liquid drained from the meter and accessories, the existing valve can be removed. The new valve assembly can then be connected and bolted to the outlet side of the meter.

Tools required for installation include:

- Screwdriver, flat blade
- Screwdriver, Phillips
- Wrench Set

### 4.3 Dwell Flow Adjustment

The dwell flow is activated by energizing S2 and de-energizing S1. This supplies the low flow chamber and raises the piston “f” until it contacts the stop nut. Adjusting this stop nut can change the dwell flow rate from between 0 and 15% of full flow.

The valve is supplied preset to allow 5% of full flow during dwell flow. This can be adjusted with the valve installed and fluid in it.

- Loosen and remove protection cap (labeled “i” in “Operation” section).
- Loosen nut “h” and move it up about 5/16 in. / 8 mm. Use a flathead screwdriver to keep shaft “m” from rotating through the S2 port.
- Supply the low flow chamber with air.
- Piston “f” will lift to the stop.
- Re-tighten nut “h” until the desired line flow is obtained.

### 4.4 Full Flow Adjustment

The valve is supplied with no opening limitation, but this can be adjusted if desired. The setting of the shutter opening (in “full flow” mode) is done by positioning the screw “o” (and the lock nut “h”) which acts as a stop for the shaft “m” attached to the shutter as shown on the diagram in the “Operation” section. The setting operation must be carried out with the valve closed.

To decrease the flow:

- Keep cap “l” locked and unscrew the M10 nut “n”
  - Adjust the M10 screw “o”

## 5. DIMENSIONAL DRAWINGS

EP7

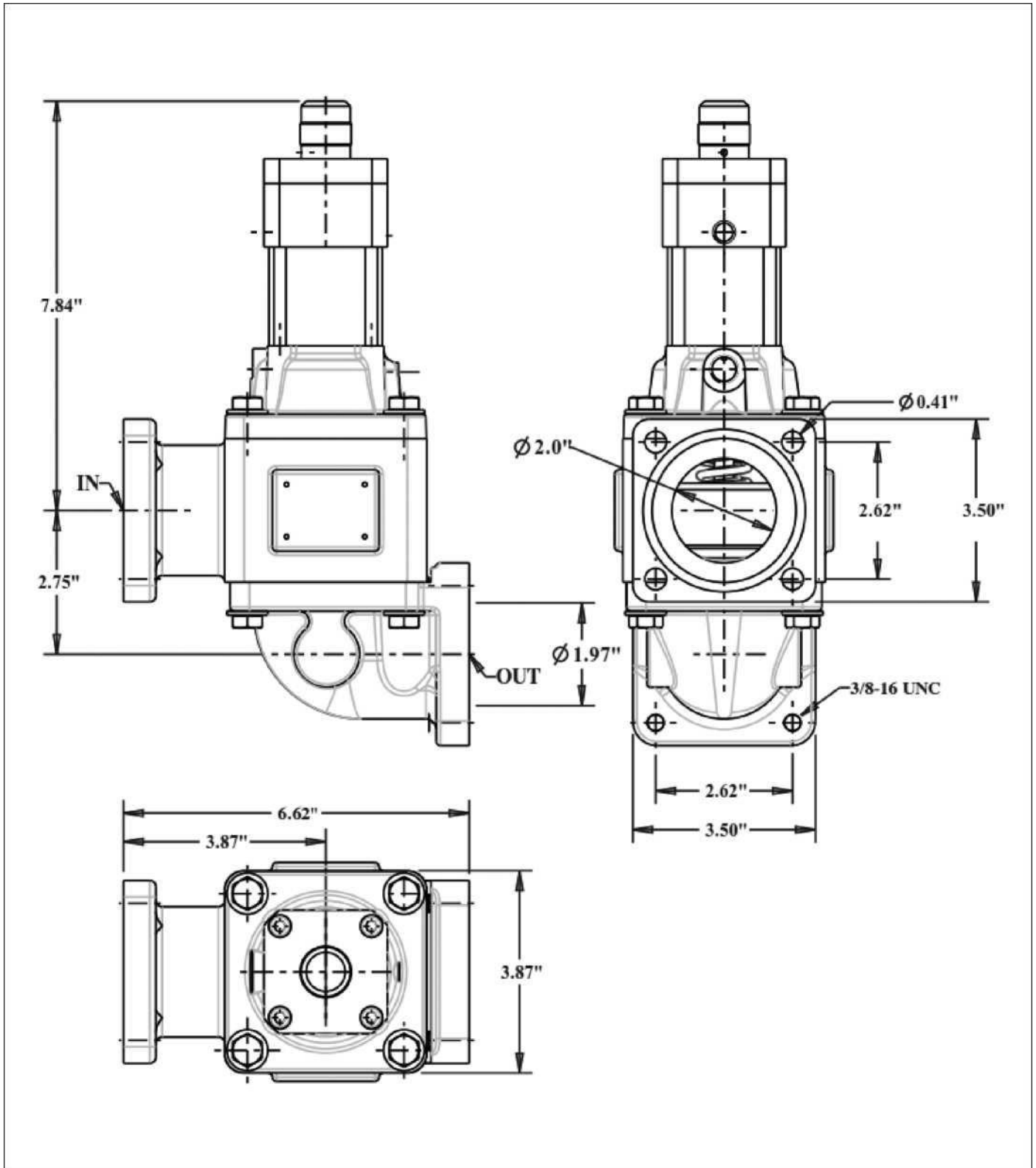

Dimensions shown are nominal. Consult factory when certified engineering drawings are required.



# 5. DIMENSIONAL DRAWINGS

EP15

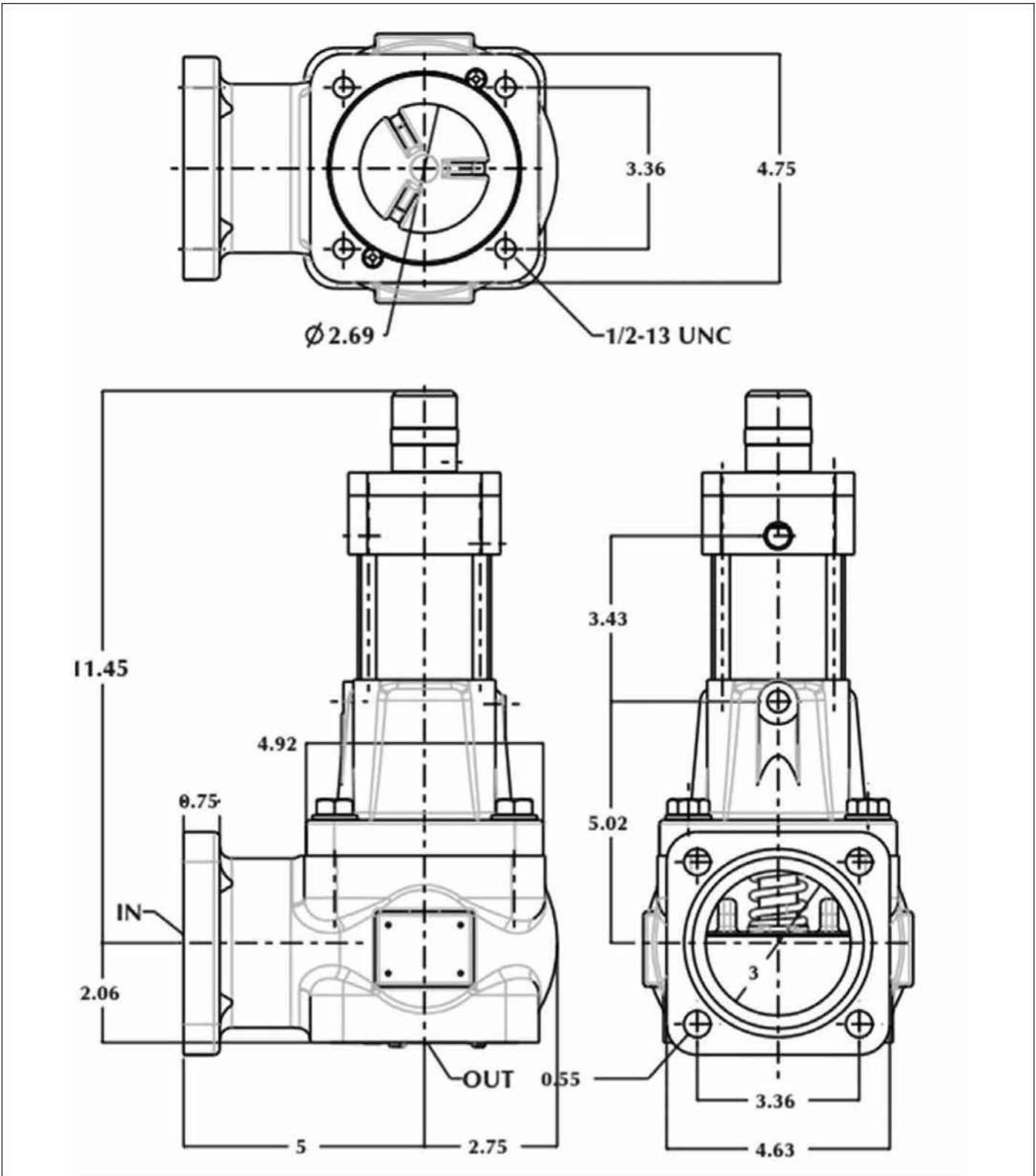

Dimensions shown are nominal. Consult factory when certified engineering drawings are required.

## 5. DIMENSIONAL DRAWINGS

EP30

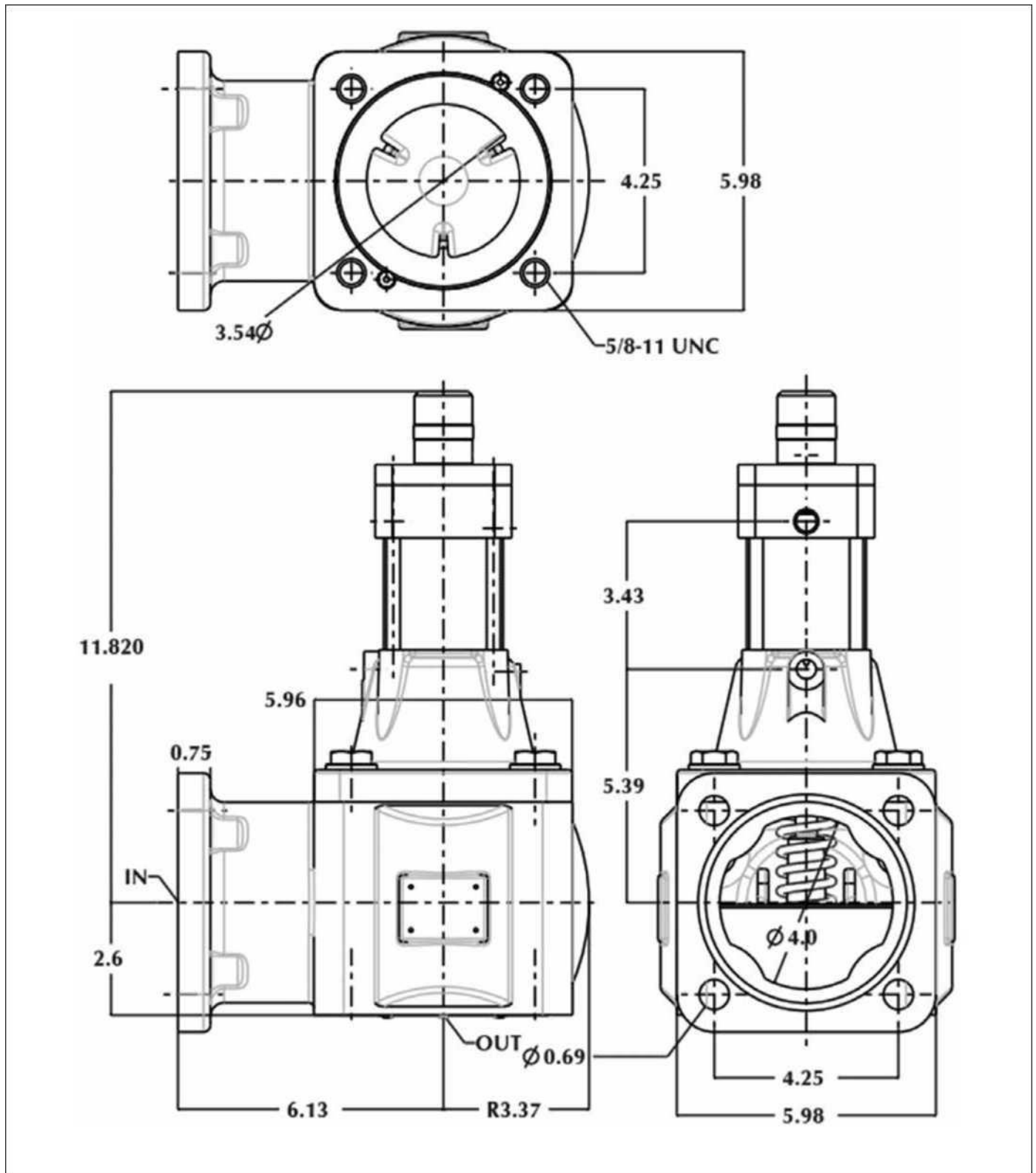

Dimensions shown are nominal. Consult factory when certified engineering drawings are required.

## 6. SPARE PARTS

Spare parts will be available in service kits. Individual parts may not be available for purchase. Contact the factory for more information.

### EP7

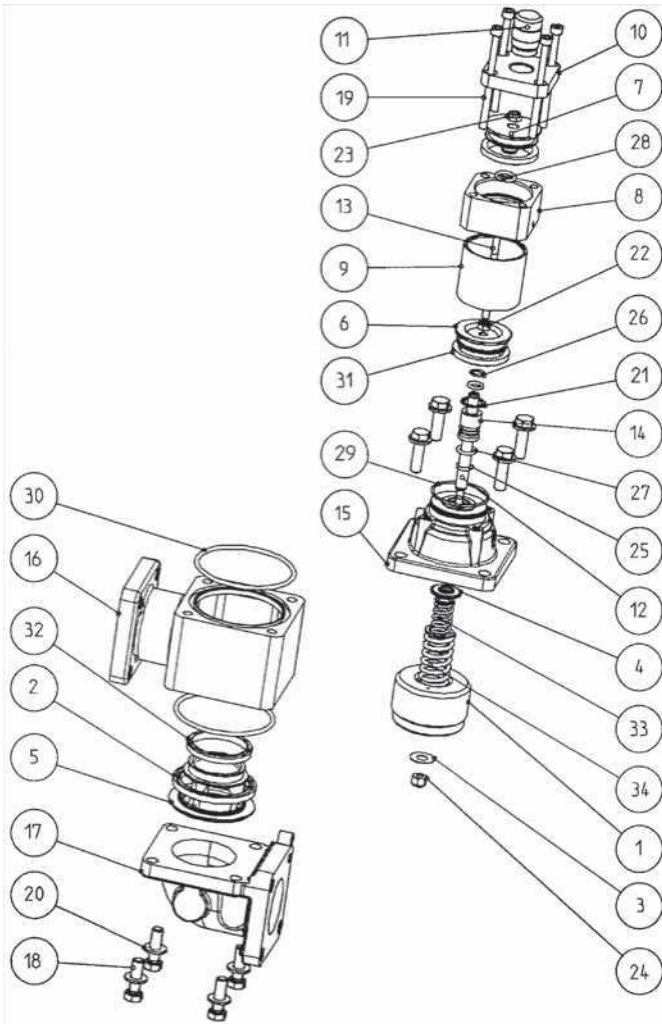

Item	Description	Seal Kit 48202	Rebuild Kit 48203
1	Bell V7-VP7		
2	Piston Stop Gasket V7-VP7	1	1
3	Brake Washer		1
4	Spring Guide Ring V7 Stainless Steel		1
5	Piston Guide V7		1
6	High Flow Piston VP7		1
7	Low Flow Piston VP7/15/30		1
8	Low Flow Cylinder VP7		1
9	High Flow Cylinder VP7		1
10	Piston Cover VP7		
11	Adjustment Cap VP7		
12	Bell Shaft VP7		
13	Upper Shaft VP7		
14	Bell Shaft Guide Bush V7-VP7		1
15	Body Cover VP7 CL.1-2-LC		
16	Valve Body VP7-VP7		
17	Ins. Outlet Curve		
18	Hex Head Screw 3/8" UNC 1-1/4"		8
19	Screw 6 PGX90 8.8Z ISO 47692		4
20	Washer		8
21	Circlips		1
22	Hex Nut M6 PG 8.8 Z UNI 5588		1
23	Self-lock Nut M6 8.8 Z DIN 985		1
24	Self-lock Nut B 1/4		1
25	O-ring	2	2
26	O-ring	1	1
27	O-ring	1	1
28	O-ring	1	1
29	O-ring	1	1
30	O-ring	2	2
31	Pradifa Lip Gasket	2	2
32	Gasket	1	1
33	Spring		1
34	Spring		1

## 6. SPARE PARTS

### EP15

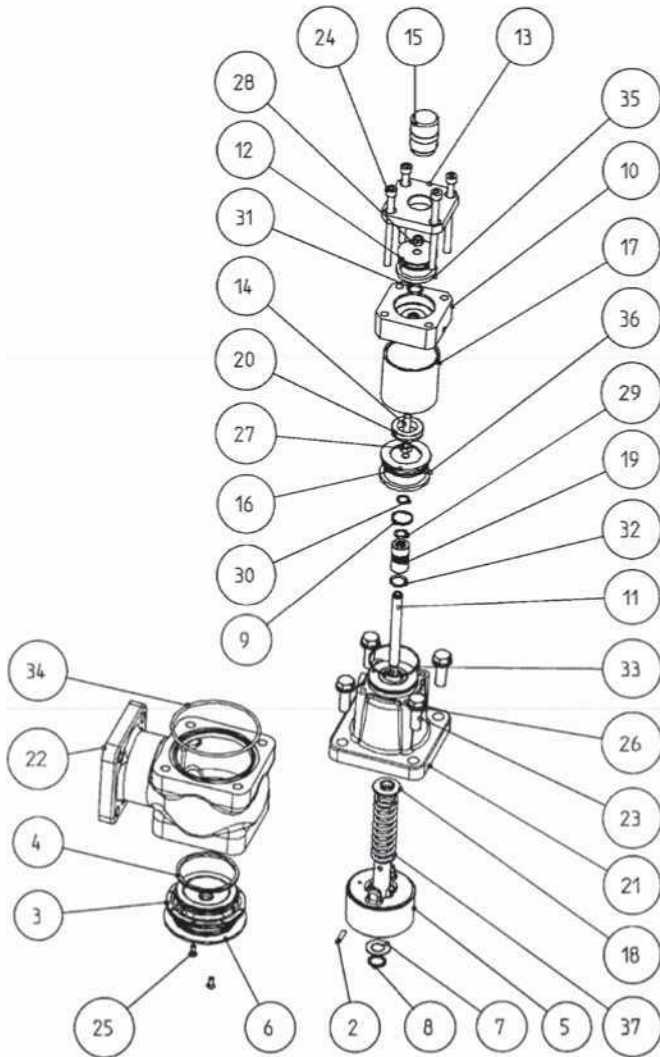

Item	Description	Seal Kit 48224	Rebuild Kit 48225
2	Snap Pin 5 x 20		1
3	Piston Stop Gasket	1	1
4	Gasket	1	1
5	Bell VP15		1
6	Piston Gude		1
7	Brake Washer		1
8	Circlips D.N. 19 (Shaft)		1
9	Circlips Bore Dia. 26		1
10	L.F Cylinder Dia. 63 VP15-30		
11	Bell Shaft VP15-30		1
12	L.F Piston VP15-30		1
13	L.F Head Cover VP15-30		
14	L.F Shaft VP15-30		1
15	Adjustment Cap		
16	H.F Piston VP15-30		1
17	H.F Cylinder VP7-15-30		
18	Spring Guide VP15-30		1
19	Shaft Guide Bush		1
20	Spacer VP15		
21	Body Cover VP15		
22	Valve Body V15-VP30		
23	Hex Head Screw 1/2" UNC X 1-1/2"		4
24	Hex Socket Screw 8 x 110 Galv.		4
25	Screw 10-24 UNC X 3/8 Galv.		2
26	Galv. Flat Washer		4
27	Hex Nut M8 Galv		1
28	Self-lock Nut M8 Galv.		1
29	O-ring	2	2
30	O-ring	1	1
31	O-ring	1	1
32	O-ring	1	1
33	O-ring	1	1
34	O-ring	1	1
35	Piston Stop Pradifa S 1540	1	1
36	Pradifa S. Gasket 1540	1	1
37	Spring		1

## 6. SPARE PARTS

### EP30

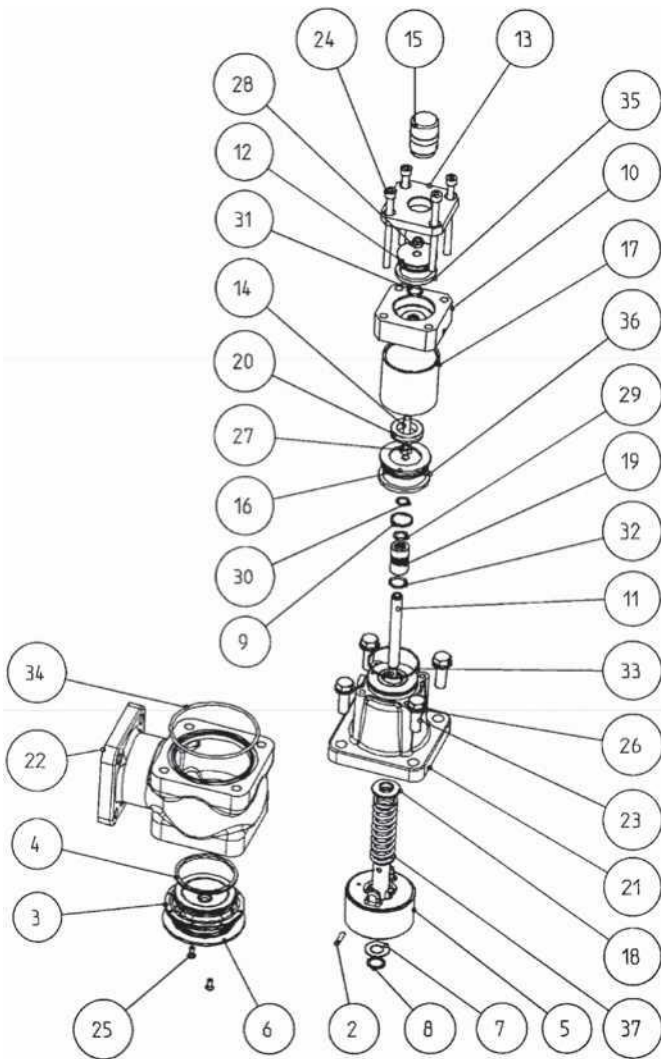

Item	Description	Seal Kit 48226	Rebuild Kit 48227
2	Snap Pin 5 x 20		1
3	Piston Stop Gasket	1	1
4	Gasket	1	1
5	Bell VP15		1
6	Piston Gude		1
7	Brake Washer		1
8	Circkips D.N. 16 (Shaft)		1
9	Circlips Bore Dia. 26		1
10	L.F Cylinder Dia. 63 VP15-30		
11	Bell Sheft VP15-30		1
12	L.F Piston VP15-30		1
13	L.F Head Cover VP15-30		
14	L.F Shaft VP15-30		1
15	Adjustment Cap		
16	H.F Piston VP15-30		1
17	H.F Cylinder VP7-15-30		
18	Spring Guide VP15-30		1
19	Shaft Guide Bush		1
20	Spacer VP15		
21	Body Cover VP15		
22	Valve Body V15-VP30		
23	Hex Head Screw W 1/2" UNC X 1-1/2"		4
24	Hex Socket Screw 8 x 110 Galv.		4
25	Screw 10-24 UNC X 3/8 Galv.		2
26	Galv. Flat Washer		4
27	Hex Nut M8 Galv		1
28	Self-lock Nut M8 Galv.		1
29	O-ring	2	2
30	O-ring	1	1
31	O-ring	1	1
32	O-ring	1	1
33	O-ring	1	1
34	O-ring	1	1
35	Piston Stop Pradifa S 1540	1	1
36	Prafida S. Gasket 1540	1	1
37	Spring		1

## 6. SPARE PARTS

### Solenoid Assembly

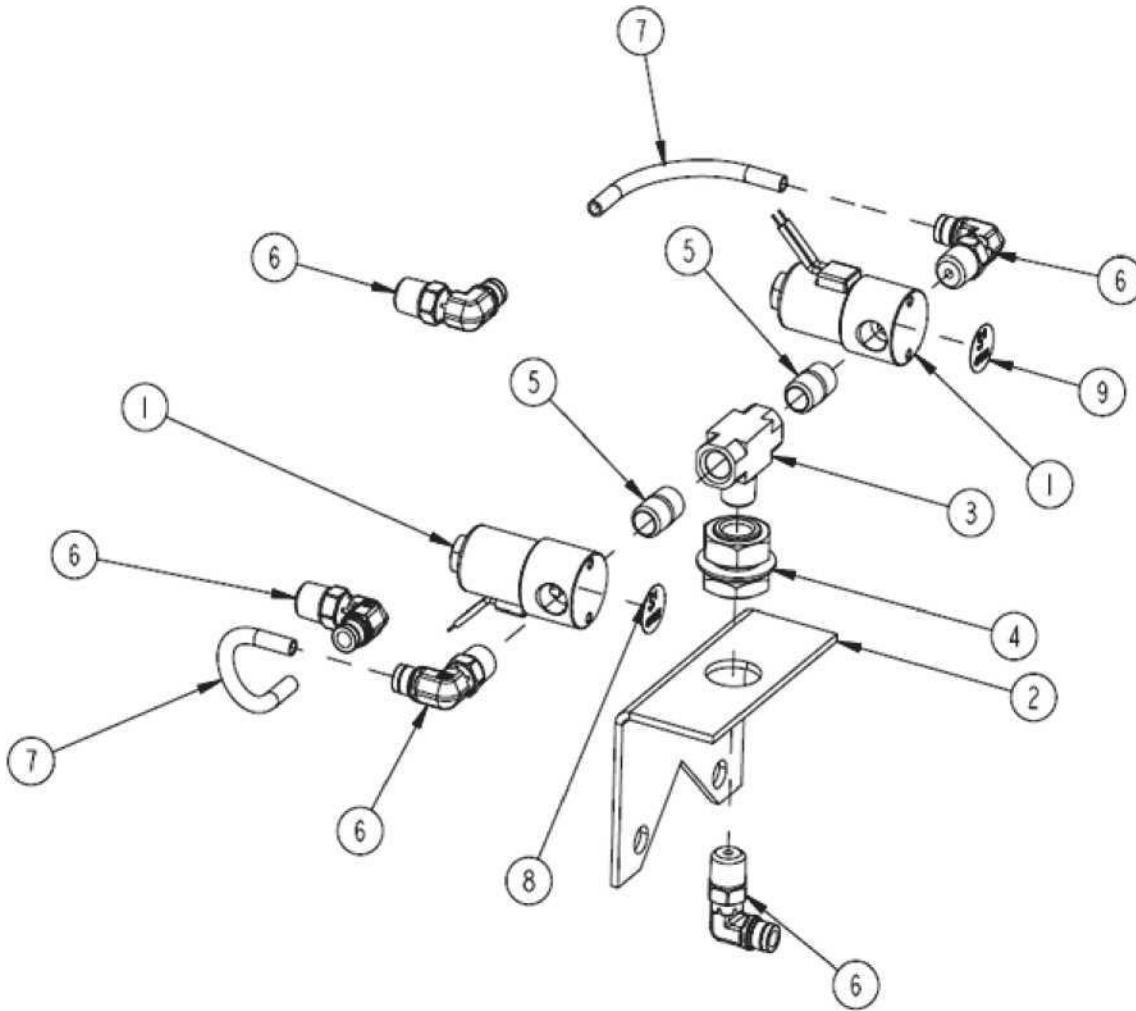

Item	Description	Quantity Included		
		Solenoid Assembly 502137	Spare Solenoid 502138	Spare Hardware Kit 502145
1	12VDC Air Solenoid	2	1	-
2	Mounting Bracket	1	-	-
3	1/4" NPT Tee	1	-	1
4	Anchor Bolt	1	-	1
5	1/4" NPT Nipple	2	-	2
6	1/4" NPT to Tube Swivel Elbow	5	-	5
7	1/4" Air Line	2 (ft)	-	-
8	S1 Decal	1	-	-
9	S2 Decal	1	-	-

# LIQUID CONTROLS GROUP



Алматы (7273)495-231  
Ангарск (3955)60-70-56  
Архангельск (8182)63-90-72  
Барнаул (3852)73-04-60  
Белгород (4722)40-23-64  
Благовещенск (4162)22-76-07  
Брянск (4832)59-03-52  
Владивосток (423)249-28-31  
Владикавказ (8672)28-90-48  
Владимир (4922)49-43-18  
Волгоград (844)278-03-48  
Вологда (8172)26-41-59  
Воронеж (473)204-51-73  
Екатеринбург (343)384-55-89  
Иваново (4932)77-34-06

Ижевск (3412)26-03-58  
Иркутск (395)279-98-46  
Казань (843)206-01-48  
Калининград (4012)72-03-81  
Калуга (4842)92-23-67  
Кемерово (3842)65-04-62  
Киров (8332)68-02-04  
Коломна (4966)23-41-49  
Кострома (4942)77-07-48  
Краснодар (861)203-40-90  
Красноярск (391)204-63-61  
Курган (3522)50-90-47  
Курск (4712)77-13-04  
Липецк (4742)52-20-81  
Магнитогорск (3519)55-03-13

Россия +7(495)268-04-70

Москва (495)268-04-70  
Мурманск (8152)59-64-93  
Набережные Челны (8552)20-53-41  
Нижегород (831)429-08-12  
Новокузнецк (3843)20-46-81  
Новосибирск (383)227-86-73  
Ноябрьск (3496)41-32-12  
Омск (3812)21-46-40  
Орел (4862)44-53-42  
Оренбург (3532)37-68-04  
Пенза (8412)22-31-16  
Пермь (342)205-81-47  
Петрозаводск (8142)55-98-37  
Псков (8112)59-10-37

Казахстан +7(7172)727-132

Ростов-на-Дону (863)308-18-15  
Рязань (4912)46-61-64  
Самара (846)206-03-16  
Санкт-Петербург (812)309-46-40  
Саранск (8342)22-96-24  
Саратов (845)249-38-78  
Севастополь (8692)22-31-93  
Симферополь (3652)67-13-56  
Смоленск (4812)29-41-54  
Сочи (862)225-72-31  
Ставрополь (8652)20-65-13  
Сургут (3462)77-98-35  
Сыктывкар (8212)25-95-17  
Тамбов (4752)50-40-97

Киргизия +996(312)96-26-47

Тверь (4822)63-31-35  
Тольятти (8482)63-91-07  
Томск (3822)98-41-53  
Тула (4872)33-79-87  
Тюмень (3452)66-21-18  
Улан-Удэ (3012)59-97-51  
Ульяновск (8422)24-23-59  
Уфа (347)229-48-12  
Хабаровск (4212)92-98-04  
Чебоксары (8352)28-53-07  
Челябинск (351)202-03-61  
Череповец (8202)49-02-64  
Чита (3022)38-34-83  
Якутск (4112)23-90-97  
Ярославль (4852)69-52-93