

Алматы (7273)495-231
Ангарск (3955)60-70-56
Архангельск (8182)63-90-72
Астрахань (8512)99-46-04
Барнаул (3852)73-04-60
Белгород (4722)40-23-64
Благовещенск (4162)22-76-07
Брянск (4832)59-03-52
Владивосток (423)249-28-31
Владикавказ (8672)28-90-48
Владимир (4922)49-43-18
Волгоград (844)278-03-48
Вологда (8172)26-41-59
Воронеж (473)204-51-73
Екатеринбург (343)384-55-89
Иваново (4932)77-34-06

Ижевск (3412)26-03-58
Иркутск (395)279-98-46
Казань (843)206-01-48
Калининград (4012)72-03-81
Калуга (4842)92-23-67
Кемерово (3842)65-04-62
Киров (8332)68-02-04
Коломна (4966)23-41-49
Кострома (4942)77-07-48
Краснодар (861)203-40-90
Красноярск (391)204-63-61
Курган (3522)50-90-47
Курск (4712)77-13-04
Липецк (4742)52-20-81
Магнитогорск (3519)55-03-13

Россия +7(495)268-04-70

Москва (495)268-04-70
Мурманск (8152)59-64-93
Набережные Челны (8552)20-53-41
Нижний Новгород (831)429-08-12
Новокузнецк (3843)20-46-81
Новосибирск (383)227-86-73
Ноябрьск (3496)41-32-12
Омск (3812)21-46-40
Орел (4862)44-53-42
Оренбург (3532)37-68-04
Пенза (8412)22-31-16
Пермь (342)205-81-47
Петрозаводск (8142)55-98-37
Псков (8112)59-10-37

Казахстан +7(7172)727-132

Ростов-на-Дону (863)308-18-15
Рязань (4912)46-61-64
Самара (846)206-03-16
Санкт-Петербург (812)309-46-40
Саранск (8342)22-96-24
Саратов (845)249-38-78
Севастополь (8692)22-31-93
Симферополь (3652)67-13-56
Смоленск (4812)29-41-54
Сочи (862)225-72-31
Ставрополь (8652)20-65-13
Сургут (3462)77-98-35
Сыктывкар (8212)25-95-17
Тамбов (4752)50-40-97

Киргизия +996(312)96-26-47

Тверь (4822)63-31-35
Тольятти (8482)63-91-07
Томск (3822)98-41-53
Тула (4872)33-79-87
Тюмень (3452)66-21-18
Улан-Удэ (3012)59-97-51
Ульяновск (8422)24-23-59
Уфа (347)229-48-12
Хабаровск (4212)92-98-04
Чебоксары (8352)28-53-07
Челябинск (351)202-03-61
Череповец (8202)49-02-64
Чита (3022)38-34-83
Якутск (4112)23-90-97
Ярославль (4852)69-52-93

crn@nt-rt.ru || <https://lcmeter.nt-rt.ru/>



Installation & Parts Manual

2" & 3" High Capacity Strainers

For Class 1, Petroleum Applications



Table of Contents

<u>Description</u>	<u>Page Number</u>	<u>Description</u>	<u>Page Number</u>
Introduction	2	2" High Capacity Strainer.....	6-7
What LC Strainers Do.....	2	Dimensional View	6
How LC Strainers Work	2	Exploded View.....	7
Features	2	3" High Capacity Strainer	8-9
Installation	3	Dimensional View	8
Maintenance.....	4-5	Exploded View.....	9
Torque Chart	5	Troubleshooting.....	10-11

Publication Updates and Translations

The most current English versions of all Liquid Controls publications are available on our website. It is the responsibility of the Local Distributor to provide the most current version of LC Manuals, Instructions, and Specification Sheets in the required language of the country, or the language of the end user to which the products are shipping . If there are questions about the language of any LC Manuals, Instructions, or Specification Sheets, please contact your Local Distributor.

! WARNING

- Before using this product, read and understand the instructions.
- Save these instructions for future reference.
- All work must be performed by qualified personnel trained in the proper application, installation, and maintenance of equipment and/or systems in accordance with all applicable codes and ordinances.
- Failure to follow the instructions set forth in this publication could result in property damage, personal injury, or death from fire and/or explosion, or other hazards that may be associated with this type of equipment.

What LC Strainers Do

Strainers protect meters from serious damage caused by burrs dislodged from new piping, pipe scale, or foreign material.

The strainer's initial cost is good insurance against the cost of down time or replacement parts incurred from a damaged meter.

A meter strainer installed on the inlet side is necessary even when a coarse strainer on the upstream side of the pump is included in the system.

Strainers are not meant to be used as a system filter but as protection for the meter element itself.

How LC Strainers Work

As liquid product enters the strainer housing from the supply line, it is routed through the strainer basket. The strainer basket is a two-ply screen. The inner screen is made of fine mesh of either 20, 40, 80, 100, or 200 squares per inch. The outer screen works as a backing. It gives reinforcement and support to the fine mesh inner screen.

Liquid product is filtered and exits the strainer basket through the screens into the strainer housing. The liquid then passes through the outlet of the strainer and into the inlet of the meter. Any debris larger than the mesh in the basket is trapped.

A properly maintained strainer helps to ensure the system owner years of trouble free service.

Features

LC markets a wide variety of strainers to fit most meters in terms of capacity, pipe size, working pressure and metallurgical compatibility. The design advantages of a Liquid Controls strainer include:

- Strainer baskets with an unusually high open basket area to pipe area ratio, resulting in minimum restriction of flow and low pressure loss.

- A choice of stainless steel strainer basket mesh sizes
 - A3430 40 Mesh
 - A3431 80 Mesh
 - A3432 100 Mesh
 - A3433 20 Mesh
 - A3434 200 Mesh

Flush All New Systems

Flushing the system before the meter has been installed is the preferred first step.

For new systems that don't currently have a meter installed, thoroughly flush the lines until the system is purged of all foreign materials. See "Maintenance" for disassembly and reassembly instructions.

For new systems with a meter installed, remove the meter's internal element components and strainer basket.

(**NOTE:** The meter housing cannot be removed in this instance.) Thoroughly flush the lines until the system is purged of all foreign materials.

Location for the Strainer

Plan a location for the strainer in the system providing for the following requirements:

- Make sure there is no pipe strain imposed upon the strainer or any other component part of the meter assembly. This means that the meter and its accessories must not support the weight of the piping.
- Plan for enough space to allow clearance so that the strainer basket cover and strainer basket can be easily removed.

Installing

Install the strainer on the inlet side of the meter. Bolt the strainer outlet to the inlet flanged connection of the meter.

Then bolt the inlet piping to the inlet flanged connection of the strainer.

Piping

New or repaired piping can be the source of welding slag

or other foreign material that will block or rupture the strainer screen. The strainer should be checked daily during the first 100 hours of operation or until no more debris is found in the strainer.

Inspection

Frequent strainer basket inspection and cleaning is required to insure proper operation.

Follow the steps outlined in "Maintenance" on the following pages.

WARNING

All internal pressures must be relieved before disassembly of the meter, strainer, air eliminator, any valves in the system, the pulse output device, or the front and rear covers. **LINE PRESSURE**

MUST BE 0.0 PSI. Refer to your meter manual for instructions on reducing the internal pressure.

Personal injury or death may result from working on a system under pressure.

Maintenance

WARNING

All internal pressures must be relieved before disassembly of the meter, strainer, air eliminator, any valves in the system, the pulse output device, or the front and rear covers. **LINE PRESSURE**

MUST BE 0.0 PSI. Refer to your meter manual for instructions on reducing the internal pressure.

Personal injury or death may result from working on a system under pressure.

It is very important to follow the strainer preventive maintenance procedures to protect the strainer as well as the metering system. Foreign matter that builds up inside the strainer, including ice, can cause damage to the strainer and the metering system. When foreign matter builds up inside the strainer, it can cause pressure

to build up inside the strainer. This pressure can cause the strainer screen to rupture. Foreign matter can then enter the metering chamber. This can cause serious damage to the meter, and may result in failure of the meter.

The following strainer preventive maintenance procedures will keep your strainer functioning properly, keep strainer repair costs to a minimum, and insure the protection of your metering system.

Newly installed or repaired systems

- Check the strainer daily during the first 100 hours of operation or until no more debris is found in the strainer.
- New or repaired piping can be the source of welding slag or other foreign particles that can block or rupture the strainer screen.
- Once a system is cleaned out, the strainer should be checked several times every season. The frequency depends on the specific service conditions, throughput, and product cleanliness.

Disassembling the Strainer

(See Page 7 for Item Numbers)

1. Carefully clean around strainer basket cover plate (2). Remove all foreign matter.
2. Remove the four bolts (7) and washers (8) from the end cover plate.
3. Remove the end cover plate (2) and O-Ring (4) from the strainer housing.
4. Remove the strainer basket. This may dislodge dirt and particles into the strainer housing.
5. Check inside the strainer housing for any foreign material. Be sure to wipe the housing clean with a clean, soft, shop rag.
6. Clean the strainer basket by flushing the basket with a liquid cleaning agent suited for your application. A soft brush may be used to dislodge imbedded particles. If the imbedded particles cannot be removed, replace the basket. Never tap the basket ends on a hard surface to dislodge particles. This may dent the basket and make reassembly difficult or cause improper sealing.
7. Clean the inner face of cover plate, mating face of the strainer body, and seal ring with a clean, soft, shop rag.
8. Make sure the O-Rings are cleaned of all dirt and grime. Check the O-Rings for damage. If the O-Rings cannot be cleaned or are damaged or frayed, replace them. Never reuse Teflon O-Rings. Always replace them even if they appear to be in good condition.

Maintenance

Reassembling the Strainer

(See Page 7 For Item Numbers)

1. Place the strainer basket into the housing.
2. Place the end cover O-Ring (4) in the groove in the end cover (2).
3. Place the end cover (2) with the O-Ring installed, on the strainer housing end (1).
4. Fasten the end cover with the 4 washers (8) and screws (7). Evenly tighten all screws.

Tightening Screws and Nuts

Leakage that occurs after tightening the fasteners indicates a damaged seal or distortion to the surface of the cover. In either of these cases, the seals or cover must be replaced. Excessive tightening will not stop the leakage. See chart below for proper torque standards.

Torque Chart

Bolt Size	Grade 5 Fasteners		Grade 8	
	Foot-Pounds	Newton-Meter	Foot-Pounds	Newton-Meter
	NOMINAL*	NOMINAL*	NOMINAL*	NOMINAL*
#8 (.164) - 32 UNC-2A	3.5	4.8		
#10 (.190) - 24 UNC-2A	5.2	7.1		
1/4" (.250) - 20 UNC-2A	7.3	9.9		
5/16" (.3125) - 18 UNC-2A	15.3	20.7		
3/8" (.375) - 16 UNC-2A	27	37		
7/16" (.4375) - 14 UNC-2A	43	58		
1/2" (.500) - 13 UNC-2A	66	90	112	152
5/8" (.625) - 11 UNC-2A	132	179	222	301
3/4" (.750) - 10 UNC-2A	233	316	395	535

*Torque specifications are $\pm 10\%$.

2" High Capacity Strainer Dimensional View

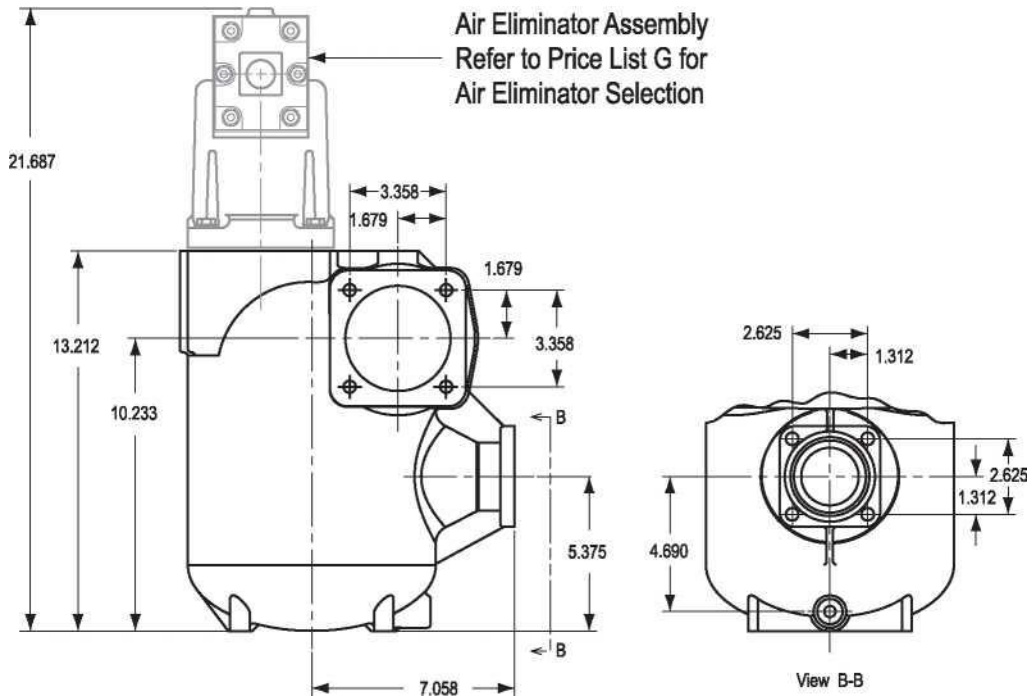
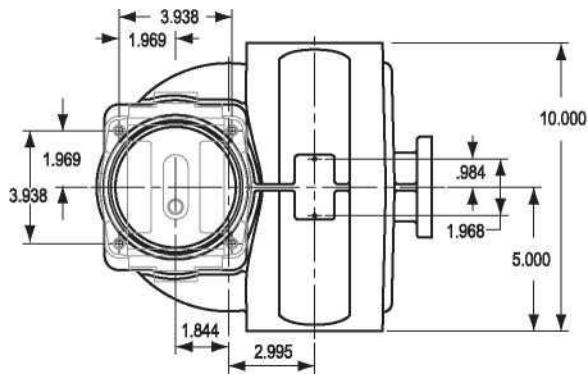

2" High Capacity Strainer Parts Breakdown

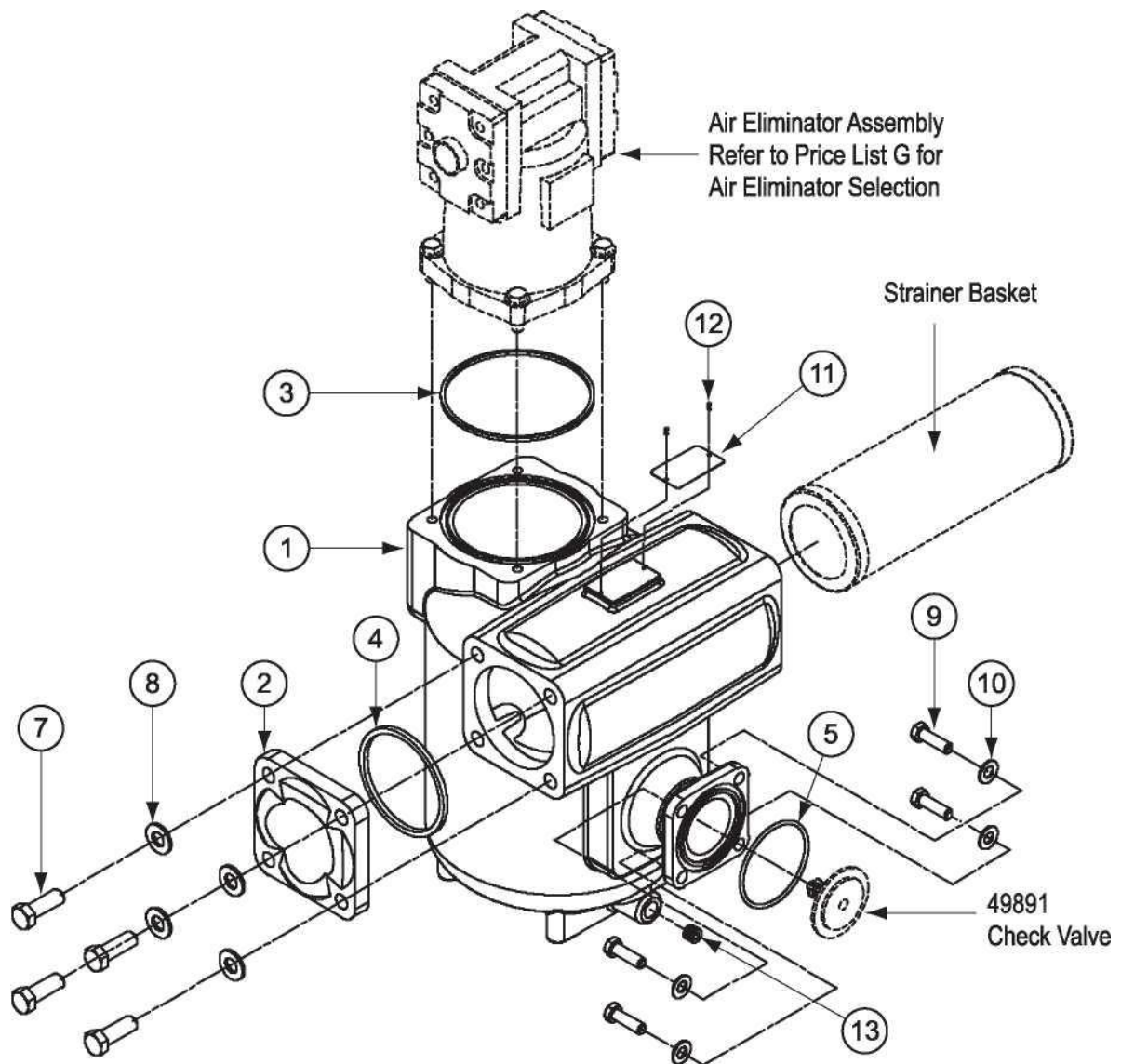

Item No.	Description	Part Number
1	Housing, Hi-Cap	N/S*
2	Strainer Cover	42987
3	O-Ring, Buna	06847
4	O-Ring, Buna	06798
5	O-Ring, Buna	06854
7	Screw, .5-13 x 1.5 (4)	06057
8	Flat Washer (4)	04685
9	Screw, .375-16 x 1.25 (4)	04444
10	Flat Washer (4)	04498
11	Name Plate	N/S
12	Screw, #2 x .19 (2)	00306S
13	Pipe Plug, .250-18 NPT	04417

*N/S: Not for Sale

3" High Capacity Strainer Dimensional View

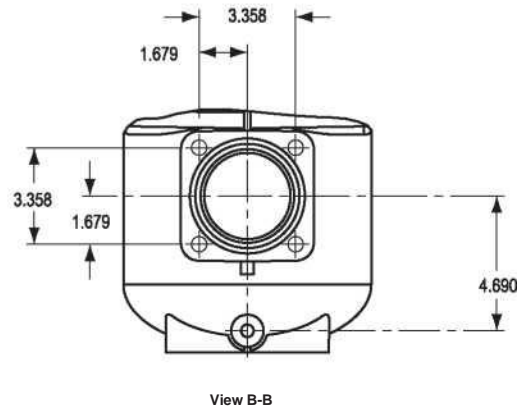
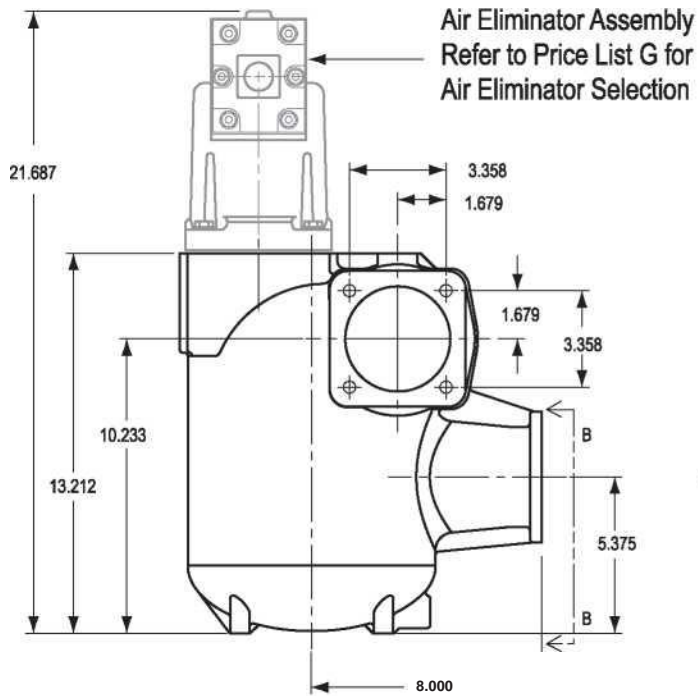
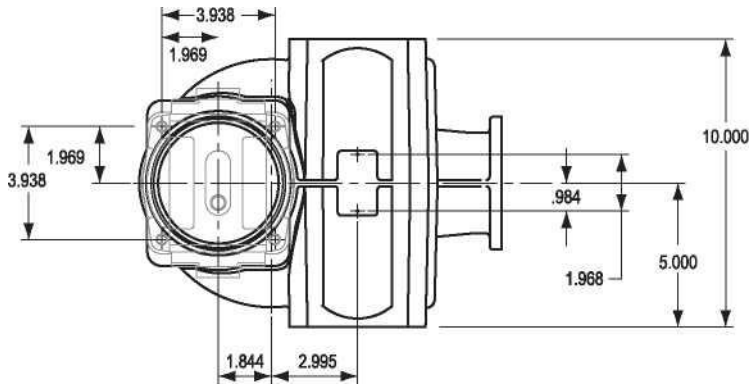

3" High Capacity Strainer Parts Breakdown

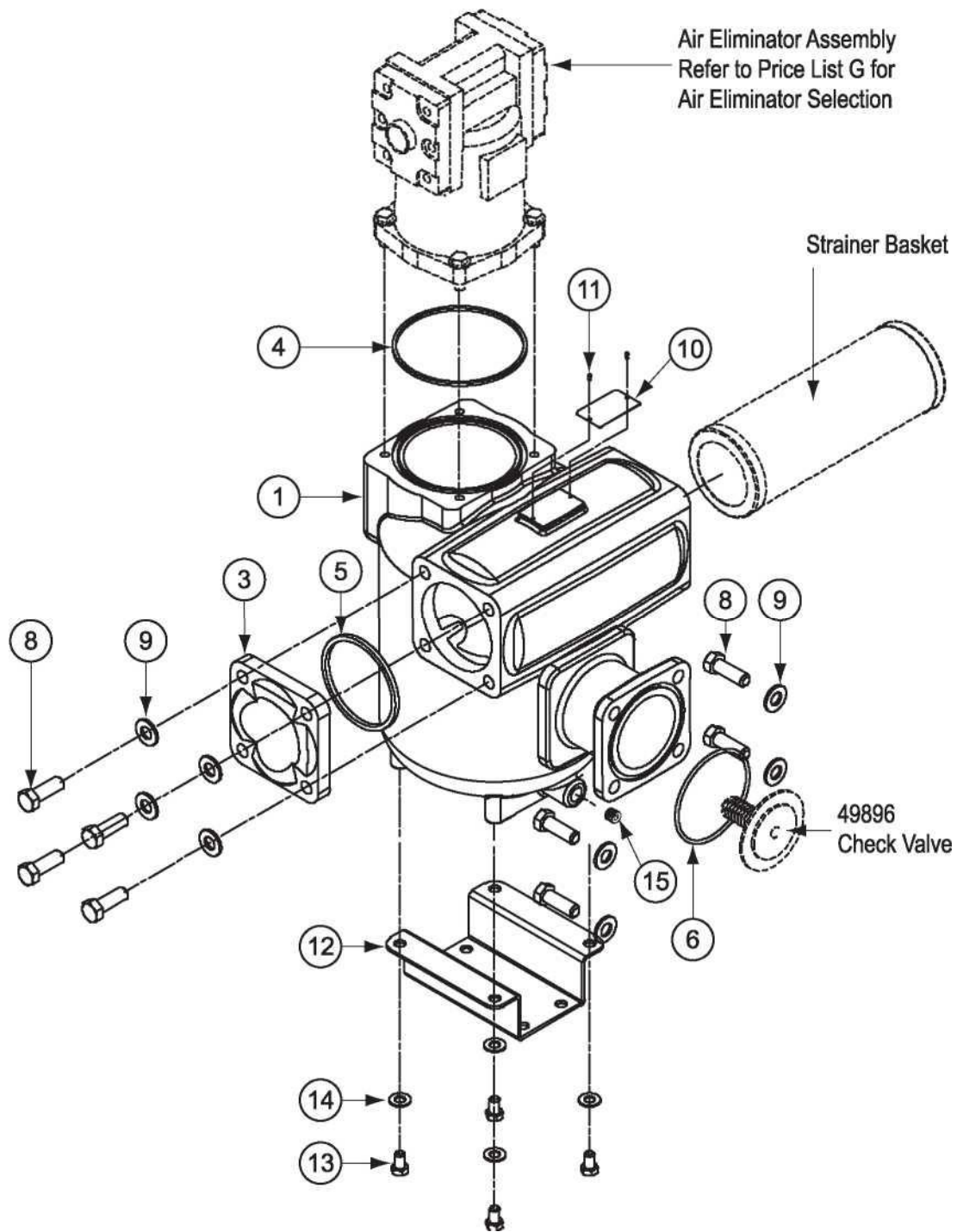

Item No.	Description	Part Number
1	Housing, Hi-Cap	N/S*
3	Strainer Cover	42987
4	O-Ring, Buna	06847
5	O-Ring, Buna	06798
6	O-Ring, Buna	04474
8	Screw, .5-13 x 1.5 (8)	06057

Item No.	Description	Part Number
9	Flat Washer (8)	04685
10	Name Plate	N/S
11	Screw, #2 x .19 (2)	00306S
12	Mounting Foot	N/S
13	Screw, .375-16 x .625 (4)	N/S
14	Flat Washer (4)	04498
15	Pipe Plug, .250-18 NPT	04417

*N/S: Not for Sale

Troubleshooting

PROBLEM 1

Meter lockup- rotors to do not turn.

PROBABLE CAUSE

Strainer basket rupture possibly due to improper maintenance of the strainer basket. If this occurred in a new system, the system may have been improperly flushed.

SOLUTION

Replace the strainer basket and follow proper strainer maintenance procedures. New systems should be flushed. In all systems, the meter chamber will require cleaning and may require replacement of parts. Refer to your meter Installation, Operation and Maintenance Manual for meter maintenance procedures or contact your full service distributor.

PROBABLE CAUSE

Debris entered the metering chamber possibly due to improper cleaning during strainer maintenance, i.e., dirt dislodged into the strainer housing when the basket was removed for cleaning.

SOLUTION

Properly clean the strainer housing as outlined in the "Maintenance" section of this manual. The meter chamber will require cleaning and may require replacement of parts. Refer to your meter Installation, Operation and Maintenance Manual for meter maintenance procedures or contact your full service distributor.

PROBABLE CAUSE

Denting or distortion of the strainer basket which opened gaps and allowed foreign particles to pass through to the meter chamber. This is usually caused by improper handling of the strainer basket during maintenance.

SOLUTION

Replace the strainer basket and follow proper strainer maintenance procedures. The meter chamber will require cleaning and may require replacement of parts. Refer to your meter Installation, Operation and Maintenance Manual for meter maintenance procedures or contact your full service distributor.

PROBLEM 2

Meter inspection due to meter inaccuracy revealed scoring of the meter chamber.

PROBABLE CAUSE

See the probable causes for Problem 1.

SOLUTION

See the solutions for Problem 1 . However, if inspection does not reveal a ruptured strainer basket and it is known that proper maintenance cleaning procedures were followed, contact your full service distributor.

Troubleshooting

PROBLEM 3

High pressure drop across the strainer or loss of flow rate.

PROBABLE CAUSE

Strainer basket screen is partially blocked by foreign material such as dried material or salted out solid particles due to drying.

SOLUTION

Properly clean the strainer housing as outlined in the "Maintenance" section. The meter chamber may require cleaning and replacement parts., Refer to your meter Installation, Operation and Maintenance Manual for meter maintenance procedures or contact your full service distributor.

PROBABLE CAUSE

Inner mesh of the strainer basket is not properly sized for the viscosity of the product.

SOLUTION

Replace the strainer basket with a basket correctly suited for the product.

PROBLEM 4

Leaking at the strainer basket cover.

PROBABLE CAUSE

The seals are allowing product to leak. This is caused by a damaged O-Ring or gasket seal, or reusing a Teflon seal after strainer maintenance.

SOLUTION

Replace the damaged seals. Replace Teflon seals if they were previously used, even if they appear to be in good condition.

PROBABLE CAUSE

Dirty areas that are preventing the seals from making complete contact.

SOLUTION

Clean the strainer housing as outlined in the Maintenance section. Remember to replace Teflon seals and not reuse them.



LIQUID CONTROLS GROUP



Алматы (7273)495-231
Ангарск (3955)60-70-56
Архангельск (8182)63-90-72
Астрахань (8512)99-46-04
Барнаул (3852)73-04-60
Белгород (4722)40-23-64
Благовещенск (4162)22-76-07
Брянск (4832)59-03-52
Владивосток (423)249-28-31
Владикавказ (8672)28-90-48
Владимир (4922)49-43-18
Волгоград (844)278-03-48
Вологда (8172)26-41-59
Воронеж (473)204-51-73
Екатеринбург (343)384-55-89
Иваново (4932)77-34-06

Ижевск (3412)26-03-58
Иркутск (395)279-98-46
Казань (843)206-01-48
Калининград (4012)72-03-81
Калуга (4842)92-23-67
Кемерово (3842)65-04-62
Киров (8332)68-02-04
Коломна (4966)23-41-49
Кострома (4942)77-07-48
Краснодар (861)203-40-90
Красноярск (391)204-63-61
Курган (3522)50-90-47
Курск (4712)77-13-04
Липецк (4742)52-20-81
Магнитогорск (3519)55-03-13

Россия +7(495)268-04-70

Москва (495)268-04-70
Мурманск (8152)59-64-93
Набережные Челны (8552)20-53-41
Нижний Новгород (831)429-08-12
Новокузнецк (3843)20-46-81
Новосибирск (383)227-86-73
Ноябрьск (3496)41-32-12
Омск (3812)21-46-40
Орел (4862)44-53-42
Оренбург (3532)37-68-04
Пенза (8412)22-31-16
Пермь (342)205-81-47
Петрозаводск (8142)55-98-37
Псков (8112)59-10-37

Казахстан +7(7172)727-132

Ростов-на-Дону (863)308-18-15
Рязань (4912)46-61-64
Самара (846)206-03-16
Санкт-Петербург (812)309-46-40
Саранск (8342)22-96-24
Саратов (845)249-38-78
Севастополь (8692)22-31-93
Симферополь (3652)67-13-56
Смоленск (4812)29-41-54
Сочи (862)225-72-31
Ставрополь (8652)20-65-13
Сургут (3462)77-98-35
Сыктывкар (8212)25-95-17
Тамбов (4752)50-40-97

Киргизия +996(312)96-26-47

Тверь (4822)63-31-35
Тольятти (8482)63-91-07
Томск (3822)98-41-53
Тула (4872)33-79-87
Тюмень (3452)66-21-18
Улан-Удэ (3012)59-97-51
Ульяновск (8422)24-23-59
Уфа (347)229-48-12
Хабаровск (4212)92-98-04
Чебоксары (8352)28-53-07
Челябинск (351)202-03-61
Череповец (8202)49-02-64
Чита (3022)38-34-83
Якутск (4112)23-90-97
Ярославль (4852)69-52-93