

Алматы (7273)495-231
Ангарск (3955)60-70-56
Архангельск (8182)63-90-72
Астрахань (8512)99-46-04
Барнаул (3852)73-04-60
Белгород (4722)40-23-64
Благовещенск (4162)22-76-07
Брянск (4832)59-03-52
Владивосток (423)249-28-31
Владикавказ (8672)28-90-48
Владимир (4922)49-43-18
Волгоград (844)278-03-48
Вологда (8172)26-41-59
Воронеж (473)204-51-73
Екатеринбург (343)384-55-89
Иваново (4932)77-34-06

Ижевск (3412)26-03-58
Иркутск (395)279-98-46
Казань (843)206-01-48
Калининград (4012)72-03-81
Калуга (4842)92-23-67
Кемерово (3842)65-04-62
Киров (8332)68-02-04
Коломна (4966)23-41-49
Кострома (4942)77-07-48
Краснодар (861)203-40-90
Красноярск (391)204-63-61
Курган (3522)50-90-47
Курск (4712)77-13-04
Липецк (4742)52-20-81
Магнитогорск (3519)55-03-13

Россия +7(495)268-04-70

Москва (495)268-04-70
Мурманск (8152)59-64-93
Набережные Челны (8552)20-53-41
Нижегород (831)429-08-12
Новокузнецк (3843)20-46-81
Новосибирск (383)227-86-73
Ноябрьск (3496)41-32-12
Омск (3812)21-46-40
Орел (4862)44-53-42
Оренбург (3532)37-68-04
Пенза (8412)22-31-16
Пермь (342)205-81-47
Петрозаводск (8142)55-98-37
Псков (8112)59-10-37

Казахстан +7(7172)727-132

Ростов-на-Дону (863)308-18-15
Рязань (4912)46-61-64
Самара (846)206-03-16
Санкт-Петербург (812)309-46-40
Саранск (8342)22-96-24
Саратов (845)249-38-78
Севастополь (8692)22-31-93
Симферополь (3652)67-13-56
Смоленск (4812)29-41-54
Сочи (862)225-72-31
Ставрополь (8652)20-65-13
Сургут (3462)77-98-35
Сыктывкар (8212)25-95-17
Тамбов (4752)50-40-97

Киргизия +996(312)96-26-47

Тверь (4822)63-31-35
Тольятти (8482)63-91-07
Томск (3822)98-41-53
Тула (4872)33-79-87
Тюмень (3452)66-21-18
Улан-Удэ (3012)59-97-51
Ульяновск (8422)24-23-59
Уфа (347)229-48-12
Хабаровск (4212)92-98-04
Чебоксары (8352)28-53-07
Челябинск (351)202-03-61
Череповец (8202)49-02-64
Чита (3022)38-34-83
Якутск (4112)23-90-97
Ярославль (4852)69-52-93

crn@nt-rt.ru || <https://lcmeter.nt-rt.ru/>



Installation & Parts Manual

K-7, K-15, & K-30

Air Actuated & Differential Check Valves



IDEX CORPORATION

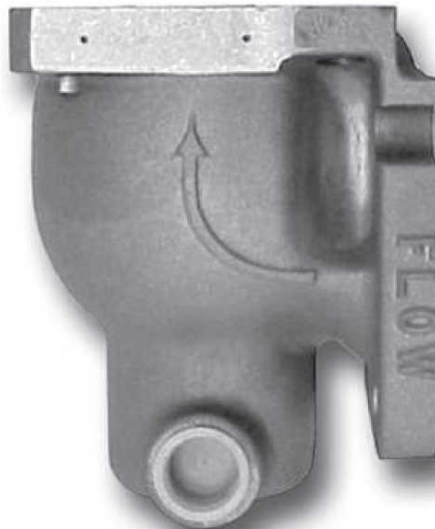

Table of Contents

Description	Page Number	Description	Page Number
General Information	2	Disassembly and Reassembly	7
Specifications	3	K-30 Valves	8
K-7 Valves	4-5	Installation	8
Installation	4	New Installations	8
New Installations	4	Retrofit Installations.....	8
Retrofit Installations.....	4	Illustrated Parts Breakdown	9-11
Disassembly and Reassembly	5	K-7 Valves	9
K-15 Valves	6-7	K-15 Valves	10
Installation	6	K-30 Valves	11
New Installations	6		
Retrofit Installations.....	6		

Publication Updates and Translations

The most current English versions of all Liquid Controls publications are available on our website. It is the responsibility of the Local Distributor to provide the most current version of LC Manuals, Instructions, and Specification Sheets in the required language of the country, or the language of the end user to which the products are shipping . If there are questions about the language of any LC Manuals, Instructions, or Specification Sheets, please contact your Local Distributor.

! WARNING

- Before using this product, read and understand the instructions.
- Save these instructions for future reference.
- All work must be performed by qualified personnel trained in the proper application, installation, and maintenance of equipment and/or systems in accordance with all applicable codes and ordinances.
- Failure to follow the instructions set forth in this publication could result in property damage, personal injury, or death from fire and/or explosion. or other hazards that may be associated with this type of equipment.

General Information

Liquid Controls Air Actuated/Differential Check Valves

are designed to prevent flow whenever air or vapor is present, thereby assuring accurate measurement.

Check Valves are normally closed, spring loaded valves installed on the meter outlet. When fluid enters the valve from the inlet side, and the pressure is greater than the back pressure combined with the force of the spring, the spring will compress, opening the valve and allowing fluid

to pass through (as shown in the figure below).

When back pressure plus spring strength is greater than the fluid pressure entering the meter, the valve will remain

closed.

These meters are used in conjunction with the air/vapor eliminator to prevent air/vapor from being metered. This is important when split compartment testing.

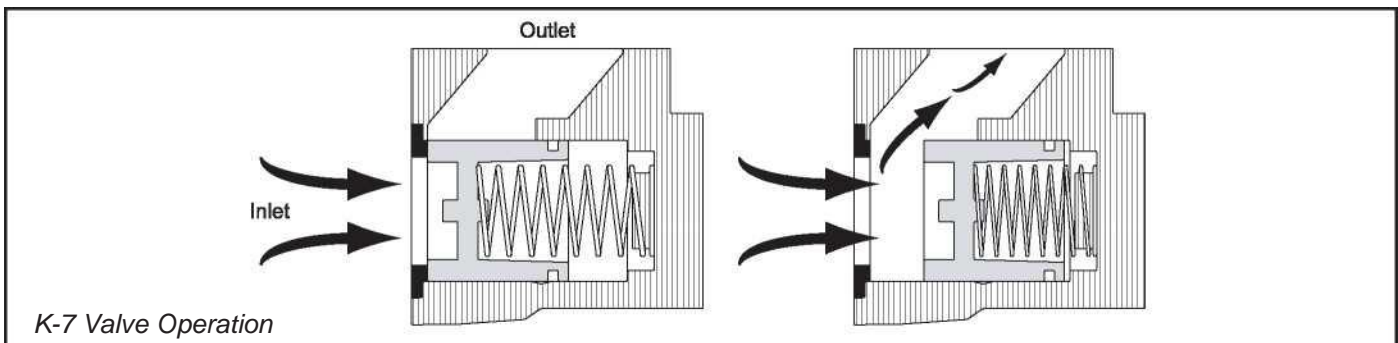

Specifications

Model/Applications

K-7 Valves:				
Used on M-5 & M-7 - 1A" & 2" Meters Maximum Flow Rate = 150 gpm (568 lpm) Working Pressure: 150 psi (10.5 bar)				
Model No.	Material	Spring	Seals	Applications
A2811	Cast Iron	Standard	Viton	Chlorinated Solvents
A2817	Aluminum	Standard	Viton	Petroleum Products
A28171	Aluminum	Medium	Viton	Petroleum Products
A28172	Aluminum	Heavy Duty	Viton	Petroleum Products
A2821	Aluminum	Standard	PTFE	Liquid Sweeteners, Methanol
A2826	Aluminum	Standard	Viton	Liquid Sweeteners
A2831	Cast Iron	Standard	PTFE	Caustics
A2851	Aluminum	Standard	EPT	NH ₃ Applications.
A2862	Stainless Steel	Standard	PTFE	Acidic PH Liquids

K-15 Valves:				
Used on M-15 & M-25 - 3" Meters Maximum Flow Rate = 300 gpm (1,136 lpm) Working Pressure = 150 psi (10.5 bar)				
Model No.	Material	Spring	Seals	Applications
A3830	Aluminum, Aluminum Guide	Standard	Viton	Aviation Fuels
A3845	Aluminum, Bronze Guide	Standard	Viton	Petroleum Products

K-30 Valve:				
Used on M-30 - 3" Meters Maximum Flow Rate = 300 gpm (1,136 lpm) Working Pressure = 150 psi (10.5 bar)				
Model No.	Material	Spring	Seals	Applications
A4845	Aluminum	Standard	Viton	Petroleum Products



K-7 Valves



K-15 & K-30 Valves

K-7 Valves

New Installations

When ordered with a new metering system, the Check Valve is supplied mounted to the metering system as shown to the right. A line must be connected to the flange on the outlet side of the 2-stage, preset valve. This connection is 2" NPT.

Finally, install a vent line from one port of the check valve to the air eliminator. Plug the other side of the check valve to the air eliminator. Plug the other side of the check valve.

Retrofit Installations

Depending on the existing configuration, adding a Check Valve may require modification of the outlet piping.

After the internal pressure is relieved from the system, the output line can be disconnected from the output side of the meter. If the system includes an electronic, 2-stage, preset valve, remove it from the meter. The check valve assembly can then be connected to the output side of the meter.

Use the four bolts and washers to fasten the valve assembly to the meter. The valve has an arrow showing the direction of flow. Ensure that the valve is properly oriented.

Tighten the bolts in a crossing pattern. Once the check valve is secure, the electronic, 2-stage, preset valve can be connected to the back check valve as shown to the right. Once this is complete, the output piping may be reconnected to the electronic, 2-stage, preset valve. The preset valve output fitting is 2" NPT.

Run a line from one port of the check valve to the air eliminator. Plug the other side of the check valve.

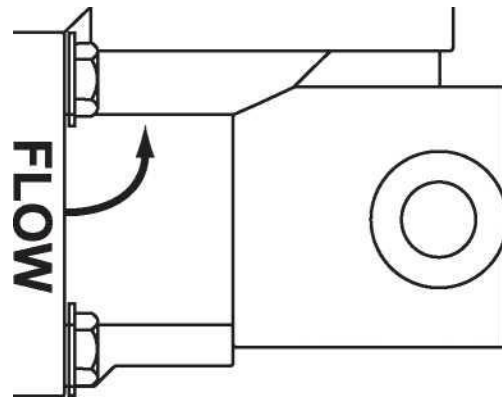
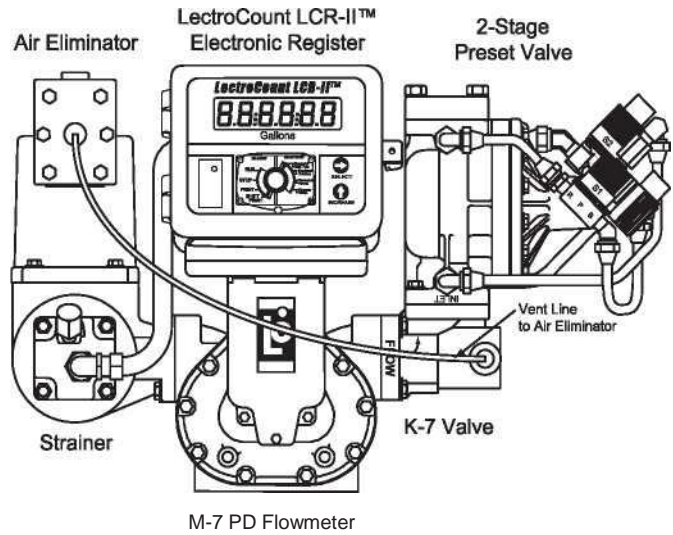

! WARNING!

Before disassembly of any meter or accessory component, **ALL INTERNAL PRESSURES MUST BE RELIEVED**. Pressure must be 0 (zero) psi. Close all liquid and vapor lines between the meter and liquid or gas pressure source (such as the supply tank, discharge lines and supply lines).

Disassembling the K-7 Valve

NOTE: Refer to the illustrated parts breakdown to the right

for Item Numbers referenced in these instructions. Item Numbers appear in circles in the drawing.

- 1 Use a fixture to press and hold the piston (Item 220) in place with the compression spring (Item 389) compressed.
- 2 Loosen the three screws (Item 615) that hold the seal ring (Item 354).
- 3 Slowly remove the fixture holding the piston (Item 220) and compression spring (Item 389) until the spring exerts NO pressure.
- 4 Remove the seal ring (Item 354), piston (Item 220) and compression spring (Item 389).
- 5 Remove the Quad Ring (Item 465) from the piston (Item 220). Replace necessary components and reassemble.

Reassembling the K-7 Valve

- 1 Place the compression spring (Item 389) over the valve stem in the valve housing (Item 110).
- 2 Place the Quad Ring (Item 465) on the piston (Item 220).
- 3 Place the piston (Item 220) over the compression spring (Item 389).
- 4 Place the seal ring (Item 354) on the piston (Item 220).
- 5 Place the piston (Item 220) and seal ring (Item 354) on top of the compression spring (Item 389) and compress using a fixture to hold the assembly in place, leaving the seal ring (Item 354) free to rotate.
- 6 Line up the holes of the seal ring assembly (Item 354) with the holes of the housing assembly (Item 110) and screw in the three screws (Item 615). Tighten the screws.
- 7 When the screws are tight, remove the fixture used to hold the piston and spring in compression.

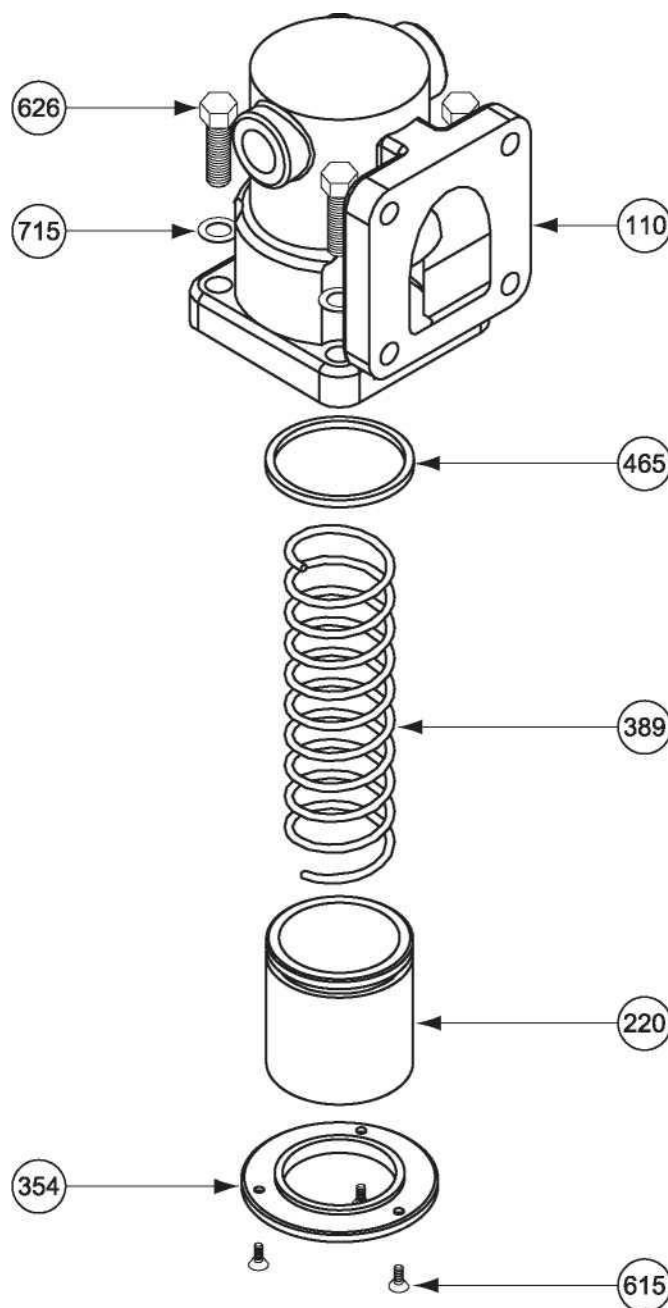

K-15 Valves

New Installations

When ordered with a new metering system, the Check Valve is supplied mounted to the metering system as shown in the example to the right. A line must be connected to the flange on the outlet side of the check valve. This flange connection is 3" NPT.

Finally, install a vent line from one port of the check valve to the air eliminator. Plug the other side of the check valve.

Retrofit Installations

Depending on the existing configuration, adding a Check Valve may require modification of the outlet piping.

After the internal pressure is relieved from the system, the output line can be disconnected from the output side of the meter. In the example to the right, the output line would be connected to the V-15 valve. The check valve assembly can then be connected to the output side of the

V-15 valve.

Use the four bolts and washers to fasten the check valve assembly to the V-15 valve. The check valve has an

arrow showing the direction of flow. Ensure that the valve is properly oriented.

Tighten the bolts in a crossing pattern. Once the check valve is secure, the output line may be reconnected to the output side of the check valve. The output fitting is 3" NPT.

A vent line must be connected from one side of the check valve to the air eliminator. Plug the other side of the

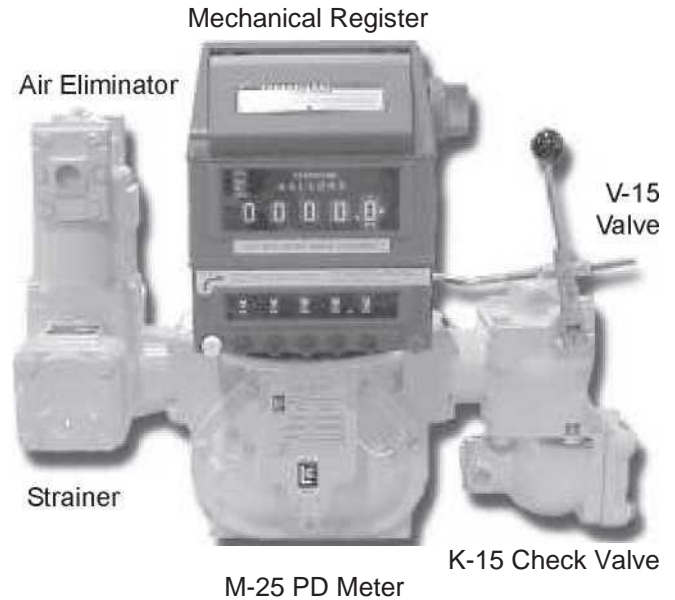

! WARNING!

Before disassembly of any meter or accessory component, **ALL INTERNAL PRESSURES MUST BE RELIEVED.** Pressure must be 0 (zero) psi. Close all liquid and vapor lines between the meter and liquid or gas pressure source (such as the supply tank, discharge lines and supply lines).

K-15 Valves

Disassembling the K-15 Valve

NOTE: Refer to the illustrated parts breakdown to the right

for Item Numbers referenced in these instructions. Item Numbers appear in circles in the drawing.

- 1 Use a fixture to press and hold the valve check guide (Item 14) in place with the compression spring (Item 15) compressed.
- 2 Remove the two screws (Item 2).
- 3 Release the pressure from the check valve guide (Item 14) until the spring (Item 15) exerts NO pressure.
- 4 Remove the check valve guide (Item 14), Quad Ring (Item 16), O-Ring (Item 9), lock ring (Item 5), compression spring (Item 15) and piston (Item 11).
- 5 Remove the retainer seal and retaining ring (Items 13 & 7), and the spring seal (Item 8).
- 6 Leave the Heli-Coil inserts in place.

Reassembling the K-15 Valve

- 1 Insert the four Heli-Coil Inserts (Item 6) into the air check housing (if they were removed).
- 2 Place the Quad Ring (Item 16) onto the large end of the piston (Item 11).
- 3 Place the check valve guide (Item 14) into the piston (Item 11).
- 4 Slide the Quad Ring (Item 16) onto the check valve guide (Item 14) and into the groove at the flanged end.
- 5 Insert the O-Ring (Item 9) with the spring facing up onto the step on the check valve guide (Item 14).
- 6 Insert the lock ring (Item 5) over the O-Ring (Item 9).
- 7 Place the check valve guide (Item 14) into the piston (Item 11).
- 8 Place the seal (Item 8) into the retainer seal (Item 13) from the end with the large chamfer and the spring (Item 15) in the seal (Item 8).
- 9 Insert the retaining ring (Item 7) into the groove of the retainer seal (Item 13) and place them into the air check housing (Item 12) with the chamfered end down. Carefully press in while visually inspecting alignment. Once alignment is adjusted, press in until seated.
- 10 Insert the compression spring (Item 15) into the bottom of the air check housing (Item 12).

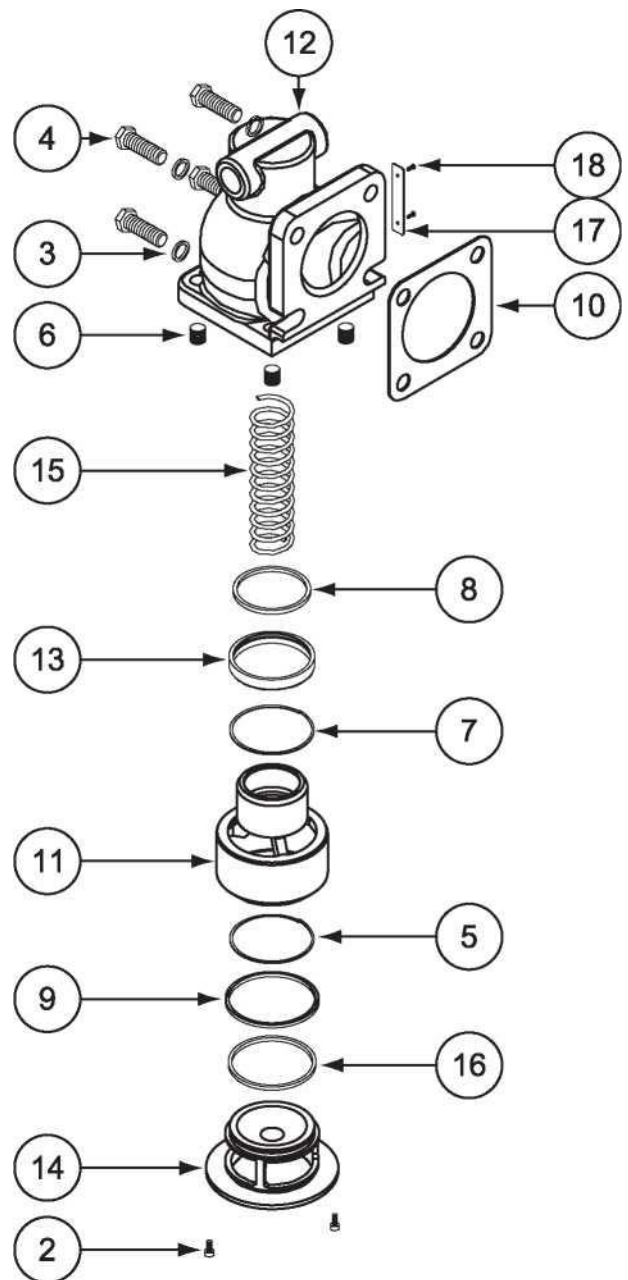

11 Place the piston (Item 11) over the compression spring (Item 15).

12 Carefully align the piston (Item 11) with the retainer seal (Item 13) and press down until the flange of the check valve guide (Item 14) is flush with the housing. This will require the use of a fixture to overcome the pressure of the spring (Item 15).

13 While holding the check valve guide in place, insert the two screws (Item 2) and tighten.

14 Remove the assembly from the fixture.

K-30 Valves

The K-30 check valve is used on M-30 3" meters. The K-30 check valve is a combination of the K-15 check valve Model A3845 and a pipe nipple assembly. The nipple assembly includes two flanges. One flange is 6" square with a 3" NPT thread, the other is 4.75" square with a 3" NPT thread. The pipe nipple is 3" in diameter and 4" in length.

The pipe nipple assembly is included in order to mount the check valve to the meter as the meter connection is larger than the check valve connection.

New Installations

When ordered with a new metering system, the K-30 Check Valve is supplied mounted to the metering system.

A line must be connected to the flange on the outlet side of the check valve. This flange connection is 3" NPT.

Finally, install a vent line from one port of the check valve to the air eliminator. Plug the other side of the check valve.

Retrofit Installations

Depending on the existing configuration, adding a Check Valve may require modification of the outlet piping.

After the internal pressure is relieved from the system, the output line can be disconnected from the output side of the meter. In the example to the right, the output line would be connected to the M-30 PD Meter. The check valve assembly can then be connected to the output side of the meter using the nipple assembly.

Use the four bolts and washers to fasten the nipple assembly to the M-30 PD Meter. Tighten the bolts in a crossing pattern.

Use the four bolts and washers to fasten the check valve to the other end of the nipple assembly. The check valve has an arrow showing the direction of flow. Ensure that the valve is properly oriented.

Tighten the bolts in a crossing pattern. Once the check valve is secure, the output line may be reconnected to the output side of the check valve. The output fitting is 3" NPT.

A vent line must be connected from one side of the check valve to one side of the air eliminator. Plug the other side of the check valve.

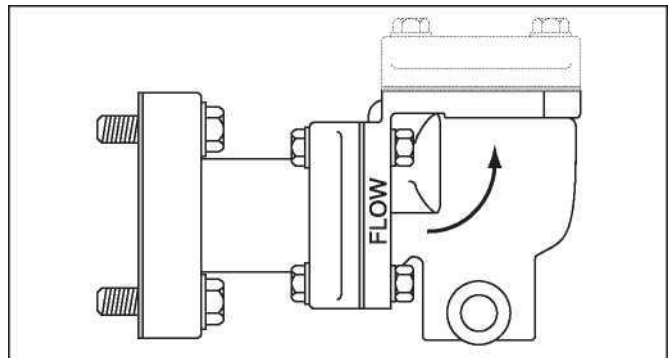
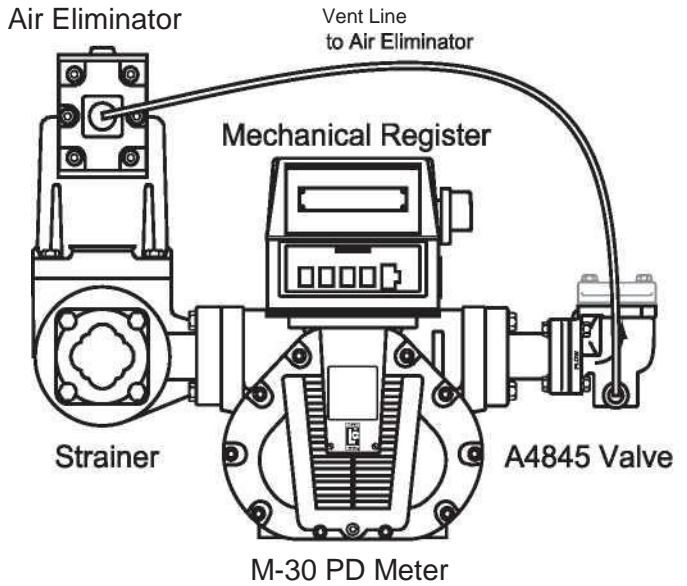

Illustrated Parts Breakdown

Model A2817: K-7 Valve

Used with M-5 & M-7, 1" & 2" meters.

Item No.	Description	Part N
110	Air Check Housing	49624
220	Piston	44676
354	Seal Ring	44669
389	Compression Spring (A2817)	41190
	Compression Spring (A28171)	45597
	Compression Spring (A28172)	45598
430	Flange Gasket	40430
465	Quad Ring	07253
475	Name Plate	N/S*
615	Screw, #6-32-3A (3)	07364
626	Screw, .375-16 x 1.25 (4)	06991
715	Flat Washer (4)	04607

Model A2851: K-7 Valve for NH₃

Used with M-5 & M-7, 1" & 2" meters.

Item No.	Description	Part N
110	Air Check Housing	49624
220	Piston	44676
354	Seal Ring Assembly	47648
389	Compression Spring	42954
465	Quad Ring	07928
475	Name Plate	N/S*
615	Screw, #6-32-3A (3)	07364
626	Screw, .375-16 (4)	06991
715	Flat Washer (4)	04607

NOTE: Item 572 listed below is a retaining ring used with

Models A2821, A2831, and A2862. It is used to secure the PTFE Seal (Item 465) on the Piston (Item 220).

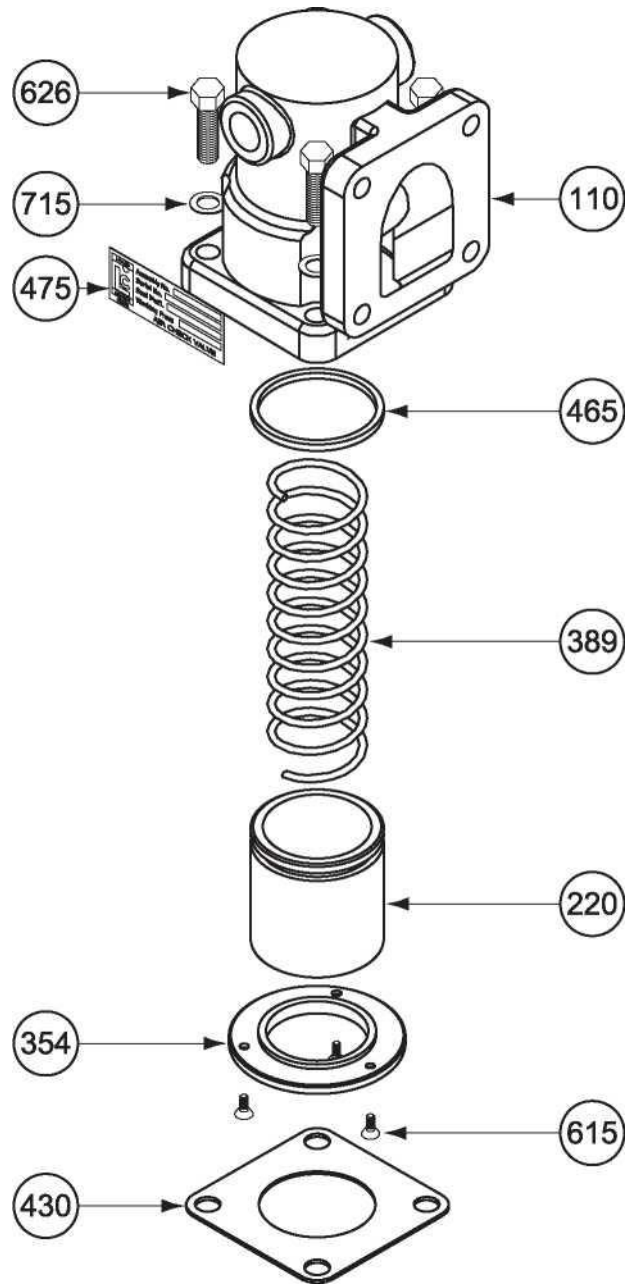

K-7 Valve Part Numbers

Model No:	A2811	A2817	A28171	A28172	A2821	A2826	A2831	A2851	A2862
Item No:	Part No:								
110	44672	49624	49624	49624	49624	49624	44672	49624	N/S
220	44674	44676	44676	44676	44677	44676	N/S	44676	45330
354	N/S*	44669	44669	44669	44669	44669	N/S	47648	N/S
389	42954	41190	45597	45598	42954	42954	42954	42954	42954
430	40430	40430	40430	40430	45818	40430	40430	N/A	45818
465	07253	07253	07253	07253	07832	07253	07832	07928	07832
572	N/A**	N/A	N/A	N/A	06044	N/A	06044	N/A	06044
615	07364	07364	07364	07364	07364	07364	07364	07364	07364
626	07319	06991	06991	06991	06991	06991	07319	06991	07497
715	04607	04607	04607	04607	04607	04607	04607	04607	06166

*N/S = Not for Sale **N/A = Not Applicable

Illustrated Parts Breakdown

Model A3830: K-15 Valve

Used with M-15 & M-25, 3" meters.

Item No.	Description	Part
		N
110	Air Check Housing	44118
133	Cup & Piston	41702
138	Guide	49924
350	Lock Ring	07207
354	Seal Retainer	44128
382	Compression Spring	44062
420	Flange Gasket	40871
452	Seal	07392
455	U-Cup	09014
465	Quad Ring	09158
521	Heli-Coil Insert, .5-13 x .5 (4)	N/S*
540	Plate	N/S
572	Retaining Ring	07391
615	Screw, #10-14 x .375 (2)	06819
626	Screw, .5-13 x 1.5 (4)	06057
738	Flat Washer (4)	04685

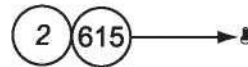
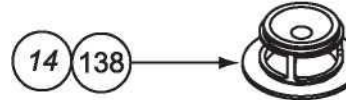
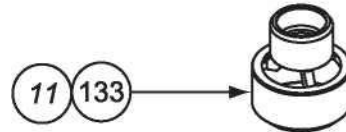
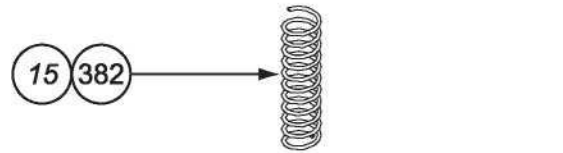
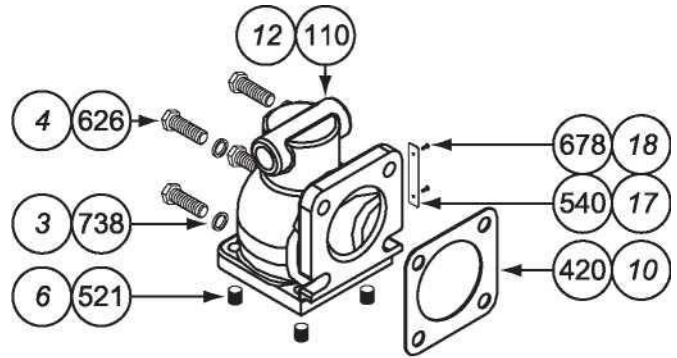

Model A3845: K-15 Valve

Used with M-15 & M-25, 3" meters. (Item No. Italic)

Item No.	Description	Part No.
2	Screw, #10-14 x .375 (2)	06819
3	Flat Washer (4)	04685
4	Screw, .5-13 x 1.5 (4)	06057
5	Lock Ring	07207
6	Heli-Coil Insert, .5-13 x .5 (4)	N/S
7	Retaining Ring	07391
8	Seal	07392
9	U-Cup	09014
10	Flange Gasket	40871
11	Cup & Piston	41702
12	Air Check Housing	44118
13	Seal Retainer	44128
14	Guide	46036
15	Compression Spring	46047
16	Quad Ring	09158
17	Plate	N/S
18	Screw	N/S

*N/S = Not for Sale

Illustrated Parts Breakdown

Model A4845: K-30 Valve

Used with M-30, 3" meters.

Item No.	Description	Part N
1	K-15 Air Check Valve Assy (See Page 9 for A3845 Parts.)	A3845
2	Flange, 3"	N/S*
3	Pipe Nipple	07150
5	Flange, 3" NPT	N/S
6	Screw, .5-13 x 2.75 (4)	06052
7	Hex Nut, .5-13 (4)	06707
8	Flange Gasket	40871
9	Flange Gasket	40704
11	Screw, .625-11 x 2.5 (4)	06466
12	Flat Washer (6)	04685
13	Flat Washer (4)	04764
14	Lock Washer (2)	06070

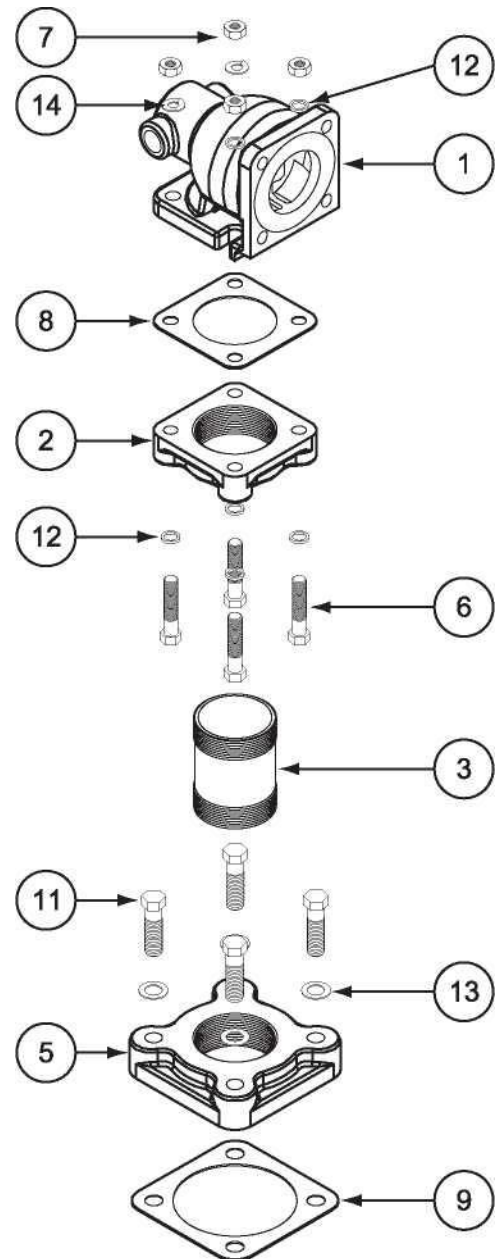

*N/S = Not for Sale



LIQUID CONTROLS GROUP



Алматы (7273)495-231
Ангарск (3955)60-70-56
Архангельск (8182)63-90-72
Астрахань (8512)99-46-04
Барнаул (3852)73-04-60
Белгород (4722)40-23-64
Благовещенск (4162)22-76-07
Брянск (4832)59-03-52
Владивосток (423)249-28-31
Владикавказ (8672)28-90-48
Владимир (4922)49-43-18
Волгоград (844)278-03-48
Вологда (8172)26-41-59
Воронеж (473)204-51-73
Екатеринбург (343)384-55-89
Иваново (4932)77-34-06

Ижевск (3412)26-03-58
Иркутск (395)279-98-46
Казань (843)206-01-48
Калининград (4012)72-03-81
Калуга (4842)92-23-67
Кемерово (3842)65-04-62
Киров (8332)68-02-04
Коломна (4966)23-41-49
Кострома (4942)77-07-48
Краснодар (861)203-40-90
Красноярск (391)204-63-61
Курган (3522)50-90-47
Курск (4712)77-13-04
Липецк (4742)52-20-81
Магнитогорск (3519)55-03-13

Россия +7(495)268-04-70

Москва (495)268-04-70
Мурманск (8152)59-64-93
Набережные Челны (8552)20-53-41
Нижегород (831)429-08-12
Новокузнецк (3843)20-46-81
Новосибирск (383)227-86-73
Ноябрьск (3496)41-32-12
Омск (3812)21-46-40
Орел (4862)44-53-42
Оренбург (3532)37-68-04
Пенза (8412)22-31-16
Пермь (342)205-81-47
Петрозаводск (8142)55-98-37
Псков (8112)59-10-37

Казахстан +7(7172)727-132

Ростов-на-Дону (863)308-18-15
Рязань (4912)46-61-64
Самара (846)206-03-16
Санкт-Петербург (812)309-46-40
Саранск (8342)22-96-24
Саратов (845)249-38-78
Севастополь (8692)22-31-93
Симферополь (3652)67-13-56
Смоленск (4812)29-41-54
Сочи (862)225-72-31
Ставрополь (8652)20-65-13
Сургут (3462)77-98-35
Сыктывкар (8212)25-95-17
Тамбов (4752)50-40-97

Киргизия +996(312)96-26-47

Тверь (4822)63-31-35
Тольятти (8482)63-91-07
Томск (3822)98-41-53
Тула (4872)33-79-87
Тюмень (3452)66-21-18
Улан-Удэ (3012)59-97-51
Ульяновск (8422)24-23-59
Уфа (347)229-48-12
Хабаровск (4212)92-98-04
Чебоксары (8352)28-53-07
Челябинск (351)202-03-61
Череповец (8202)49-02-64
Чита (3022)38-34-83
Якутск (4112)23-90-97
Ярославль (4852)69-52-93