

Алматы (7273)495-231
Ангарск (3955)60-70-56
Архангельск (8182)63-90-72
Астрахань (8512)99-46-04
Барнаул (3852)73-04-60
Белгород (4722)40-23-64
Благовещенск (4162)22-76-07
Брянск (4832)59-03-52
Владивосток (423)249-28-31
Владикавказ (8672)28-90-48
Владимир (4922)49-43-18
Волгоград (844)278-03-48
Вологда (8172)26-41-59
Воронеж (473)204-51-73
Екатеринбург (343)384-55-89
Иваново (4932)77-34-06

Ижевск (3412)26-03-58
Иркутск (395)279-98-46
Казань (843)206-01-48
Калининград (4012)72-03-81
Калуга (4842)92-23-67
Кемерово (3842)65-04-62
Киров (8332)68-02-04
Коломна (4966)23-41-49
Кострома (4942)77-07-48
Краснодар (861)203-40-90
Красноярск (391)204-63-61
Курган (3522)50-90-47
Курск (4712)77-13-04
Липецк (4742)52-20-81
Магнитогорск (3519)55-03-13

Россия +7(495)268-04-70

Москва (495)268-04-70
Мурманск (8152)59-64-93
Набережные Челны (8552)20-53-41
Нижний Новгород (831)429-08-12
Новокузнецк (3843)20-46-81
Новосибирск (383)227-86-73
Ноябрьск (3496)41-32-12
Омск (3812)21-46-40
Орел (4862)44-53-42
Оренбург (3532)37-68-04
Пенза (8412)22-31-16
Пермь (342)205-81-47
Петрозаводск (8142)55-98-37
Псков (8112)59-10-37

Казахстан +7(7172)727-132

Ростов-на-Дону (863)308-18-15
Рязань (4912)46-61-64
Самара (846)206-03-16
Санкт-Петербург (812)309-46-40
Саранск (8342)22-96-24
Саратов (845)249-38-78
Севастополь (8692)22-31-93
Симферополь (3652)67-13-56
Смоленск (4812)29-41-54
Сочи (862)225-72-31
Ставрополь (8652)20-65-13
Сургут (3462)77-98-35
Сыктывкар (8212)25-95-17
Тамбов (4752)50-40-97

Киргизия +996(312)96-26-47

Тверь (4822)63-31-35
Тольятти (8482)63-91-07
Томск (3822)98-41-53
Тула (4872)33-79-87
Тюмень (3452)66-21-18
Улан-Удэ (3012)59-97-51
Ульяновск (8422)24-23-59
Уфа (347)229-48-12
Хабаровск (4212)92-98-04
Чебоксары (8352)28-53-07
Челябинск (351)202-03-61
Череповец (8202)49-02-64
Чита (3022)38-34-83
Якутск (4112)23-90-97
Ярославль (4852)69-52-93

crn@nt-rt.ru || <https://lcmeter.nt-rt.ru/>



Mechanical Temperature Volume Compensators

Models D5120, D5121, D5122

Installation, Operation, and Parts



LIQUID CONTROLS™

An IDEX Energy & Fuels Business

PUBLICATION UPDATES AND TRANSLATIONS

The most current English versions of all Liquid Controls publications are available on our web site. It is the responsibility of the local distributor to provide the most current version of LC manuals, instructions, and specification sheets in the required language of the country, or the language of the end user to which the products are shipping. If there are questions about the language of any LC manuals, instructions, or specification sheets, please contact your local distributor.

The documentation is only complete when used in combination with the relevant documentation for the signal converter.

All rights reserved. It is prohibited to reproduce this documentation, or any part thereof, without the prior written authorization of Liquid Controls, LLC.

Content is subject to change without notice.

11/2016 Mechanical Temperature Volume Compensators Models D5120, D5121, & D5122

Copyright 2016 by Liquid Controls, LLC.

TABLE OF CONTENTS

INTRODUCTION

Introduction3
How the TVC Works3

INSTALLATION

Installation4
Field Adjustment5
Coefficients of Expansion.....6
Exploded View.....7

WARNING

Be Prepared

Before using this product, read and understand the instructions.

- All work must be performed by qualified personnel trained in the proper application, installation, and maintenance of equipment and/or systems in accordance with all applicable codes and ordinances.
- When handling electronic components and boards, always use proper Electrostatic Discharge (ESD) equipment and follow the proper procedures
- Make sure that all necessary safety precautions have been taken.
- Provide for proper ventilation, temperature control, fire prevention, evacuation, and fire management.
- Provide easy access to the appropriate fire extinguishers for your product.
- Consult with your local fire department, state, and local codes to ensure adequate preparation.
- Read this manual as well as all the literature provided in your owner's packet.
- Save these instructions for future reference.
- Failure to follow the instructions set forth in this publication could result in property damage, personal injury, or death from fire and/or explosion, or other hazards that may be associated with this type of equipment.



INTRODUCTION

Introduction

Mechanical Temperature Volume Compensators (TVC) are installed on liquid meters as part of the register stack. TVCs automatically adjust for product volume changes due to temperature changes. It is characteristic of liquid products to increase in volume when the temperature rises and to decrease in volume when the temperature lowers. For example, a temperature change of 20 °F for LPG results in a 3.4% change in volume.

The extent to which a liquid increases in volume per one degree Fahrenheit or Centigrade is known as its coefficient of expansion. For example, the coefficient of expansion of gasoline is approximately 0.0006 per one degree Fahrenheit (depending on the additive content). The coefficient of expansion of liquid propane gas (LPG) is approximately 0.0017 per one degree Fahrenheit.

The Mechanical Temperature Volume Compensator is designed to:

1. Permit the maximum accurate calibration of the meter and therefore the maximum accuracy in delivery.
2. Reduce the incidences of overfilling large storage tanks for deliveries in hot weather.
3. Prevent accidental overcharging or undercharging for delivered product. Because volume increases or decreases with temperature while price per unit volume is a fixed amount (typically set at 60 °F (15 °C)), the total price for the same amount of fuel can fluctuate according to the temperature. Not all Weights & Measures allow TVC on gasoline or fuel oil.
4. Provide maximum precision for the input feed of liquids in industrial batching processes.

Three models of Temperature Volume Compensators are available:

- D5120 Fixed Gravity (for LPG)
- D5121 Fixed Gravity (for gasoline/solvents)
- D5122 Fixed Gravity (for distillates)

How the Temperature Volume Compensator (TVC) Works

The Fixed Gravity Temperature Volume Compensators are designed for the single product use of liquid propane gas, distillates, gasolines/solvents, or other light hydrocarbons. The TVC compensates for changes in product volume based on temperature through the interaction of three subsystems: a thermal sensing device, a lever arm assembly, and a speed change mechanism.

The fluid in the temperature sensing bulb expands or contracts with changes in product temperature. Any expansion or contraction of the sensing fluid causes the product bellows in the TVC to expand or contract accordingly. The lever arm assembly transmits the bellows motion to the speed change mechanism. The speed change mechanism adjusts the drive ratio between the meter and the mechanical register to match.

When the temperature is 60 °F (15 °C), a 1:1 output ratio is supplied to the register. When temperature rises, the TVC compensates for the increase in volume supplying the register with a ratio less than 1:1. If the metered liquid temperature falls below 60 °F (15 °C), the TVC will supply a ratio greater than 1:1.

Features

- Heavy duty, heat treated, positive ratchet drive assures zero slippage and the long life of the speed change mechanism.
- Operating temperature range from -30 to 120 °F (-35 to 48.8 °C). Consult factory for high temperatures.
- The TVC is factory set for LPG, distillates, or gasolines/solvents to a liquid base temperature of 60 °F (15 °C).

INSTALLATION

The TVC is shipped with a bellows assembly installed. This system is calibrated so the TVC and the sensing bellows are a matched set. Should the bellows become damaged or fail, the TVC assembly must be removed and sent back to the factory or an authorized service center to have a replacement bellows installed and calibrated to the TVC.

To Install A TVC To An Existing Meter

If adapting to a meter not previously supplied with a TVC, a thermowell and a gear plate change may be required.

1. Remove the four bolts holding the register to the meter. Remove the register from the meter. Be careful not to damage the register or TVC drive shafts.
2. Line up the TVC's input driver with the slot in the meter adjuster, and lower the TVC onto the meter. Attach the TVC to the meter with the four bolts provided.
3. Line up the register's input driver with the slot in the TVC output driver, and lower the register onto the TVC. Attach the register to the TVC using the four bolts provided.

Handle the Bellows with Care

When handling the temperature sensing bellows assembly, be careful not to form sharp bends in the capillary tube.

4. Slide the thermowell cap over the temperature sensing bellows. Remove the plastic bag from the sensing bellows to expose the thermally conductive grease. Insert the sensing bellows into the thermowell.
5. Install the two slotted steel washers and the two slit, rubber washers on the capillary tube. Push the washer into the thermowell.
6. Thread the thermowell cap into the thermowell until it is hand tight. Pack the thermowell cap with caulking putty (3M 8575 or equivalent).
7. Perform the meter proving procedures as outlined in Field Adjustment section of this manual.

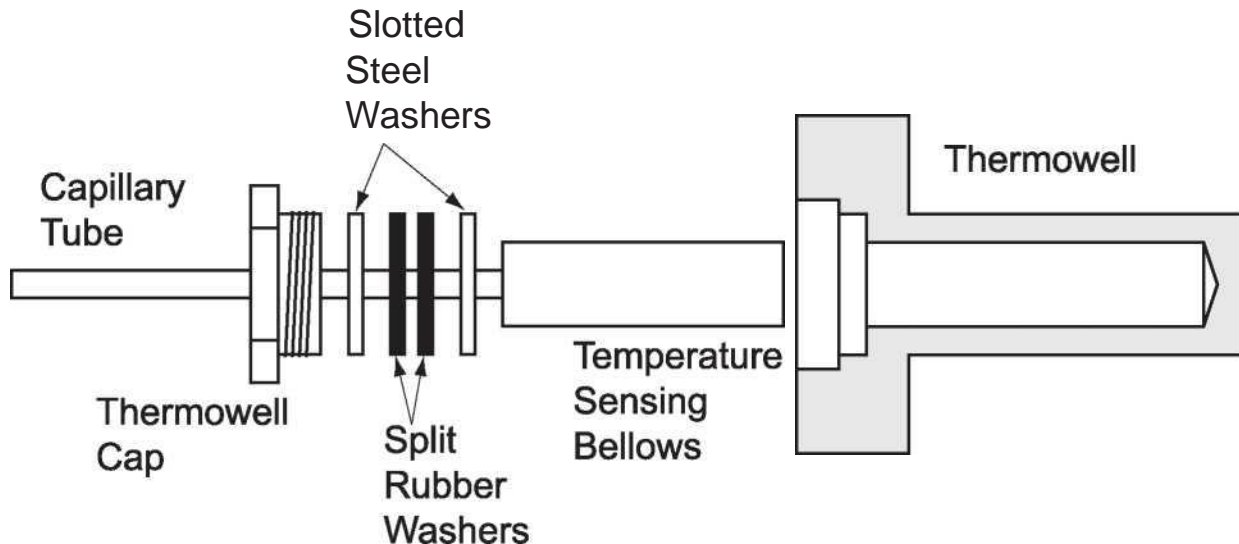
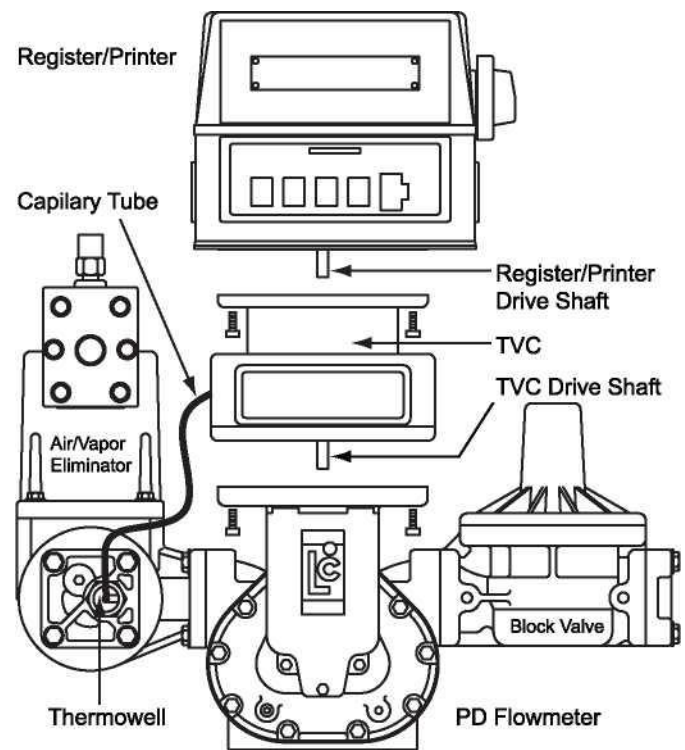

FIELD ADJUSTMENT

Field Adjustment

Before shipment, every TVC is calibrated at the coefficient of expansion and base temperature specified by the customer; however, after the meter is calibrated, the TVC may require further adjustment.

To make adjustments to the TVC in the field:

1. Operate the system and observe whether the register is running smoothly (without hesitation and in a normal manner). If the register is running smoothly, proceed to Step 2. If not, determine the cause of the problem and make corrective action. Refer to the register's manual for troubleshooting suggestions.
2. Deactivate the TVC by removing the four cover screws and moving the lockout pin from Position A to Position B. This locks the TVC input-to-output ratio at 1:1.

Deactivate the TVC before proving the meter.

3. With the TVC deactivated, prove the meter according to the specified procedures. If prover runs indicate that the meter itself is not accurate, consult the meter manual for meter adjustments.
4. With the meter proved, reactivate the TVC by returning the lockout pin Position A.
5. Before making a prover run with the TVC activated, be sure to check the Temperature Sensing Bulb and Capillary Tube have no leaks. Sharp bends in the tube can create leaks. If damage is indicated, replace the TVC. Replacement of the temperature sensing elements require shop recalibration of the TVC.
6. With the TVC in the activated position, make several prover runs. The % error need not be within acceptable tolerance, but the difference between maximum and minimum results should be in tolerance. If the results do not repeat with tolerance, replace the TVC. If the runs repeat, but are not within compensated meter tolerances, adjust as follows:

a. Compute the required adjustment per the formula:

- b. Adjust the "CALIBRATION ADJUSTMENT" screw to eliminate the error. For the D5120 each graduation on the adjustment screw represents a 0.10% change in volume. For the D5121 and D5122 3 graduations on the adjustment screw represents a 0.10% change in volume. Turning the screw clockwise increases the volume delivered; counterclockwise decreases the volume delivered. If adjustments exceed one full revolution in either direction, consult the factory.

$$\% \text{ Error} = \frac{(\text{Prover Quantity} - \text{Meter Measurement})}{\text{Prover Quantity}} \times 100$$

- c. After the adjustment has been made, replace the cover.

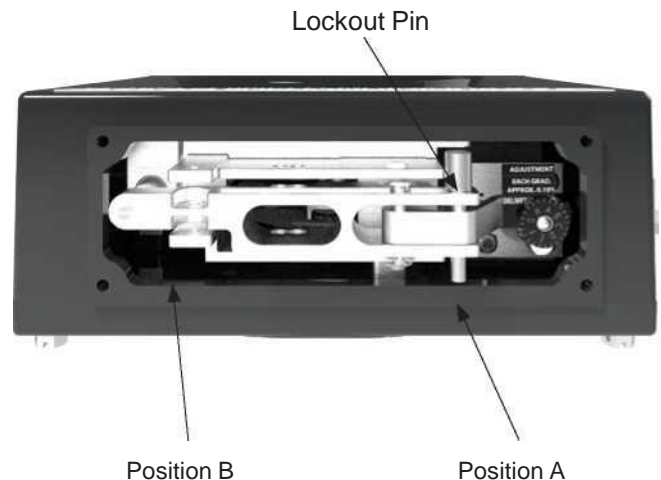
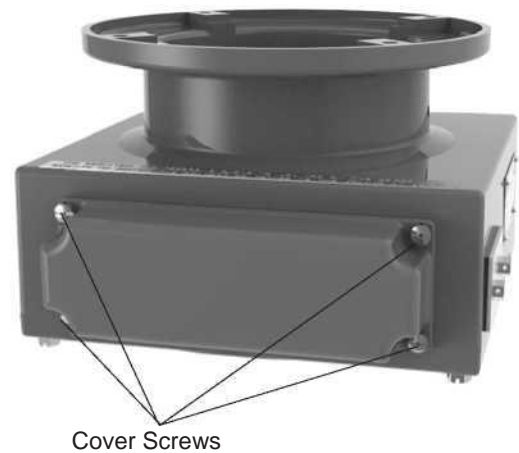

Calibration Adjustment Screw

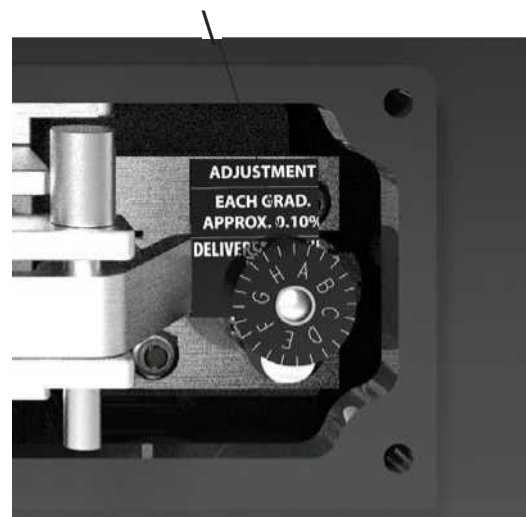

COEFFICIENTS OF EXPANSION

Model Number		Coefficient of Expansion	
		per Degree Fahrenheit	per Degree Celsius
D5121	Alcohol	.0006	.0011
D5122	Aviation Fuel	.0005	.0009
D5121	Benzene	.0006	.0011
D5122	Bunker C	.0005	.0009
D5122	Carbontetrachloride	.0006	.0011
D5122	Crude Oil	.0005	.0009
D5122	Diesel Fuel	.0005	.0009
D5121	Diethyl Ketone	.0006	.0011
D5121	Ethanol	.0006	.0011
D5121	Ethyl Mercaptan	.0006	.0011
D5122	Fuel Oil #2, #6	.0005	.0009
D5121	Gasoline	.0006	.0011
D5121	Heptane	.0006	.0011
D5121	Iso-Butyl Alcohol	.0006	.0011
D5122	Isopropanol	.0005	.0009
D5122	JP-4 (Jet Fuel)	.0005	.0009
D5122	Kerosene	.0005	.0009
D5120	LPG	.0017	.0031
D5121	Methanol	.0006	.0011
D5121	Methyl Alcohol	.0006	.0011
D5122	Mineral Spirits	.0005	.0009
D5122	Oil & Fatty Acids	.0005	.0009
D5122	Styrene	.0005	.0009
D5121	Toluene	.0006	.0011
D5121	Unleaded Gasoline	.0006	.0011
D5122	Vegetable Oil	.0005	.0009
D5122	Vinegar	.0005	.0009
D5121	Xylene	.0006	.0011

Calculating Volume Change

To compute the change in volume for a temperature change for a given liquid, use the formula:

$$(At)(\text{Coefficient of Expansion})(100) = \% \text{ change in volume}$$

For example:

$$\text{Coefficient of Expansion of Gasoline} = 0.0006 \text{ per } ^\circ \text{ F}$$

$$\text{Temperature change (At)} = 10^\circ \text{ F}$$

$$(10^\circ \text{ F})(.0006/^\circ \text{ F})(100) = 0.6\% \text{ change in volume}$$

EXPLODED VIEW

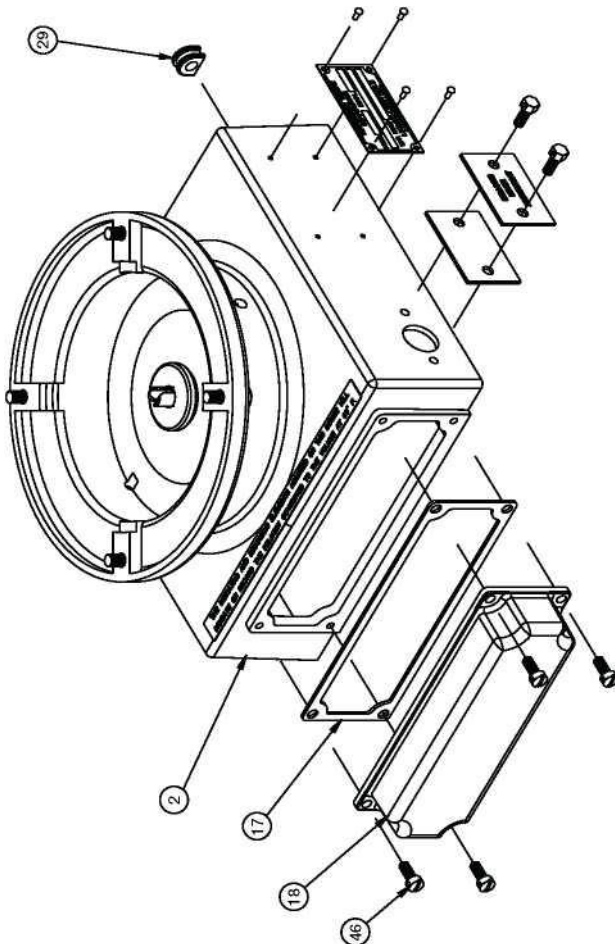
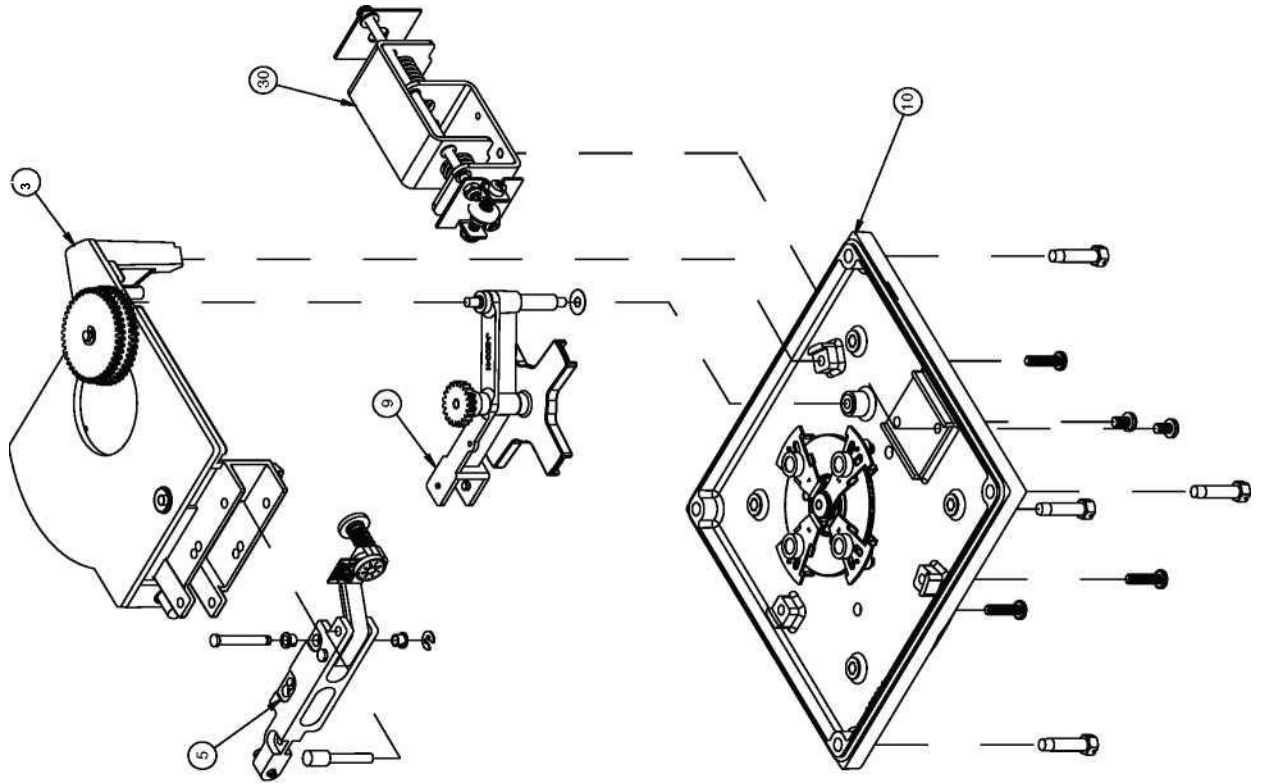

Replacing the Bellows

If the bellows are damaged, they must be installed and calibrated by a professional technician. The TVC must be removed from the flowmeter and the register and returned to an authorized Liquid Controls distributor.



LIQUID CONTROLS GROUP



Алматы (7273)495-231
Ангарск (3955)60-70-56
Архангельск (8182)63-90-72
Барнаул (3852)73-04-60
Белгород (4722)40-23-64
Благовещенск (4162)22-76-07
Брянск (4832)59-03-52
Владивосток (423)249-28-31
Владикавказ (8672)28-90-48
Владимир (4922)49-43-18
Волгоград (844)278-03-48
Вологда (8172)26-41-59
Воронеж (473)204-51-73
Екатеринбург (343)384-55-89
Иваново (4932)77-34-06

Ижевск (3412)26-03-58
Иркутск (395)279-98-46
Казань (843)206-01-48
Калининград (4012)72-03-81
Калуга (4842)92-23-67
Кемерово (3842)65-04-62
Киров (8332)68-02-04
Коломна (4966)23-41-49
Кострома (4942)77-07-48
Краснодар (861)203-40-90
Красноярск (391)204-63-61
Курган (3522)50-90-47
Курск (4712)77-13-04
Липецк (4742)52-20-81
Магнитогорск (3519)55-03-13

Россия +7(495)268-04-70

Москва (495)268-04-70
Мурманск (8152)59-64-93
Набережные Челны (8552)20-53-41
Нижегород (831)429-08-12
Новокузнецк (3843)20-46-81
Новосибирск (383)227-86-73
Ноябрьск (3496)41-32-12
Омск (3812)21-46-40
Орел (4862)44-53-42
Оренбург (3532)37-68-04
Пенза (8412)22-31-16
Пермь (342)205-81-47
Петрозаводск (8142)55-98-37
Псков (8112)59-10-37

Казахстан +7(7172)727-132

Ростов-на-Дону (863)308-18-15
Рязань (4912)46-61-64
Самара (846)206-03-16
Санкт-Петербург (812)309-46-40
Саранск (8342)22-96-24
Саратов (845)249-38-78
Севастополь (8692)22-31-93
Симферополь (3652)67-13-56
Смоленск (4812)29-41-54
Сочи (862)225-72-31
Ставрополь (8652)20-65-13
Сургут (3462)77-98-35
Сыктывкар (8212)25-95-17
Тамбов (4752)50-40-97

Киргизия +996(312)96-26-47

Тверь (4822)63-31-35
Тольятти (8482)63-91-07
Томск (3822)98-41-53
Тула (4872)33-79-87
Тюмень (3452)66-21-18
Улан-Удэ (3012)59-97-51
Ульяновск (8422)24-23-59
Уфа (347)229-48-12
Хабаровск (4212)92-98-04
Чебоксары (8352)28-53-07
Челябинск (351)202-03-61
Череповец (8202)49-02-64
Чита (3022)38-34-83
Якутск (4112)23-90-97
Ярославль (4852)69-52-93