

Алматы (7273)495-231
Ангарск (3955)60-70-56
Архангельск (8182)63-90-72
Астрахань (8512)99-46-04
Барнаул (3852)73-04-60
Белгород (4722)40-23-64
Благовещенск (4162)22-76-07
Брянск (4832)59-03-52
Владивосток (423)249-28-31
Владикавказ (8672)28-90-48
Владимир (4922)49-43-18
Волгоград (844)278-03-48
Вологда (8172)26-41-59
Воронеж (473)204-51-73
Екатеринбург (343)384-55-89
Иваново (4932)77-34-06

Ижевск (3412)26-03-58
Иркутск (395)279-98-46
Казань (843)206-01-48
Калининград (4012)72-03-81
Калуга (4842)92-23-67
Кемерово (3842)65-04-62
Киров (8332)68-02-04
Коломна (4966)23-41-49
Кострома (4942)77-07-48
Краснодар (861)203-40-90
Красноярск (391)204-63-61
Курган (3522)50-90-47
Курск (4712)77-13-04
Липецк (4742)52-20-81
Магнитогорск (3519)55-03-13

Россия +7(495)268-04-70

Москва (495)268-04-70
Мурманск (8152)59-64-93
Набережные Челны (8552)20-53-41
Нижний Новгород (831)429-08-12
Новокузнецк (3843)20-46-81
Новосибирск (383)227-86-73
Ноябрьск (3496)41-32-12
Омск (3812)21-46-40
Орел (4862)44-53-42
Оренбург (3532)37-68-04
Пенза (8412)22-31-16
Пермь (342)205-81-47
Петрозаводск (8142)55-98-37
Псков (8112)59-10-37

Казахстан +7(7172)727-132

Ростов-на-Дону (863)308-18-15
Рязань (4912)46-61-64
Самара (846)206-03-16
Санкт-Петербург (812)309-46-40
Саранск (8342)22-96-24
Саратов (845)249-38-78
Севастополь (8692)22-31-93
Симферополь (3652)67-13-56
Смоленск (4812)29-41-54
Сочи (862)225-72-31
Ставрополь (8652)20-65-13
Сургут (3462)77-98-35
Сыктывкар (8212)25-95-17
Тамбов (4752)50-40-97

Киргизия +996(312)96-26-47

Тверь (4822)63-31-35
Тольятти (8482)63-91-07
Томск (3822)98-41-53
Тула (4872)33-79-87
Тюмень (3452)66-21-18
Улан-Удэ (3012)59-97-51
Ульяновск (8422)24-23-59
Уфа (347)229-48-12
Хабаровск (4212)92-98-04
Чебоксары (8352)28-53-07
Челябинск (351)202-03-61
Череповец (8202)49-02-64
Чита (3022)38-34-83
Якутск (4112)23-90-97
Ярославль (4852)69-52-93

crn@nt-rt.ru || <https://lcmeter.nt-rt.ru/>



CONTROLS
®

Optical Vapor Eliminator (US Patent #70000628)

Installation and Parts



TABLE OF CONTENTS

INTRODUCTION

Safety Procedures.....	3
Specifications.....	4
General Information.....	4
How Optical Vapor Eliminators Work.....	5

INSTALLATION

Dimensional Drawing.....	7
New Installations.....	8
Retrofit Installations.....	8
Wiring.....	10

MAINTENANCE

S3 Solenoid Disassembly.....	12
S3 Solenoid Reassembly.....	13
Optical Sensor Replacement.....	14
Troubleshooting.....	14

BILL OF MATERIALS

Exploded Views.....	15
---------------------	----

NOTICE

This manual provides warnings and procedures that are intended to inform the owner and/or operator of the hazards present when using the Liquid Controls Meter on LP-Gas and other products. The reading of these warnings and the avoidance of such hazards is strictly in the hands of the owner-operators of the equipment. Neglect of that responsibility is not within the control of the manufacturer of the meter.

Be Prepared

- WARNING

- Before using this product, read and understand the instructions.
- All work must be performed by qualified personnel trained in the proper application, installation, and maintenance of equipment and/or systems in accordance with all applicable codes and ordinances.
- When handling electronic components and boards, always use proper Electrostatic Discharge (ESD) equipment and follow the proper procedures
- Make sure that all necessary safety precautions have been taken.
- Provide for proper ventilation, temperature control, fire prevention, evacuation, and fire management.
- Provide easy access to the appropriate fire extinguishers for your product.
- Consult with your local fire department, state, and local codes to ensure adequate preparation.
- Read this manual as well as all the literature provided in your owner's packet.
- Save these instructions for future reference.
- Failure to follow the instructions set forth in this publication could result in property damage, personal injury, or death from fire and/or explosion, or other hazards that may be associated with this type of equipment.

Publication Updates and Translations

The most current English versions of all Liquid Controls publications are available on our web site. It is the responsibility of the local distributor to provide the most current version of LC manuals, instructions, and specification sheets in the required language of the country, or the language of the end user to which the products are shipping. If there are questions about the language of any LC manuals, instructions, or specification sheets, please contact your local distributor.

Safely Evacuate Piping System

A WARNING

Before disassembly of any meter or accessory component:

- **All internal pressures must be relieved and all liquid drained from the system in accordance with all applicable procedures.,**
- **Pressure must be 0 (zero) psi.**
- **Close all liquid and vapor lines between the meter and liquid source.**

Failure to follow this warning could result in property damage, personal injury, or death from fire and/or explosion, or other hazards that may be associated with this type of equipment.

In the Event of a Gas Fire



IN THE EVENT OF LARGE FIRES OR FIRES THAT ARE SPREADING

- Evacuate the building and notify your local fire department.
- Stop the leakage only if you can safely reach the equipment.

IN THE EVENT OF SMALL, CONTAINED FIRES THAT YOU CAN SAFELY CONTROL

- Stop the leakage if you can safely reach the equipment.
- Use the appropriate extinguisher: Class B fire extinguisher, water, fog, etc., depending on the materials.
- If in doubt, call your local fire department.

In the Event of a Gas Leak



IN THE EVENT OF A LARGE GAS LEAK

- Evacuate the area and notify the fire department.

IN THE EVENT OF A SMALL, CONTAINED GAS LEAK

- Stop the leak and prevent accidental ignition.
 - Prevent the entrance of gas into other portions of the buildings. Some gases, such as LPG, seek lower levels, while other gases seek higher levels.
 - Evacuate all people from the danger zone.
 - See that the gas is dispersed before resuming business and operating motors.
- If in doubt, notify your local fire department.

SPECIFICATIONS

Optical Vapor Eliminators (A8302)

Materials of Construction

Body: Anodized Aluminum

Solenoid: Brass

Pressure Rating

Maximum non-shock working pressure

• 350 PSI (24.1 BAR)

Temperature Rating

-40° to 160°F (-40° to 71 °C)

Solenoid (S3)

Voltage: +12 (± 2) VDC

+24 (± 4) VDC *available upon request*

Current: 1 Amp maximum

General Information

Liquid Controls Optical Vapor Eliminator (A8302) is designed for use with LectroCount® electronic registers and require the use of a solenoid-operated valve. It is constructed to be used with Liquid Controls MA5 and MA7 meters measuring liquid propane gas. Because it is designed with the same mounting dimensions as Liquid Controls mechanical vapor eliminators, the optical vapor eliminator requires minimal plumbing changes in order to retrofit to existing meter installations of the same application. Electronic registers require CPU board part number 81920 for LCR and LCR-II; CPU board part number 81924 for LC³.

NOTICE

A8302 LPG metering systems use materials specifically intended for their application to ensure high performance, longevity and above all safety. ***Under no circumstances should a system designed for LPG be used to deliver another product*** without first replacing the necessary metallurgical and seal materials specified for the application. Conversion kits are available from Liquid Controls.

INTRODUCTION

How the Optical Vapor Eliminator Works

The Liquid Controls Optical Vapor Eliminator removes vapor from the metering system. Removing the vapor from the metering system ensures that only liquid can pass through the meter for measurement.

An optical sensor, installed in the wall of the vapor eliminator housing, activates and deactivates a solenoid valve (S3) located at the top of the vapor eliminator.

When the liquid level is below the optical sensor (and a delivery is initiated) the solenoid valve opens to vent vapor to a supply or storage tank (Figure 1). At the same time, the electronically actuated control valve, located at the meter outlet, closes to stop the flow of product.

As vapor is exhausted and liquid rises over the optical sensor level, the optical vapor eliminator solenoid valve (S3) closes the vent while the electronically actuated control valve opens so that a delivery may begin or continue (Figure 2).

As long as a delivery is active and the liquid level remains at or above the optical sensor, the optical vapor eliminator solenoid valve (S3) remains closed and the electronically actuated control valve remains open. If the liquid level drops below the optical sensor, the optical vapor eliminator solenoid valve (S3) opens to vent the vapor, and the outlet control valve closes blocking product flow.

When the delivery is complete, both the outlet control valve and the optical vapor eliminator solenoid valve close until activated for a new delivery.

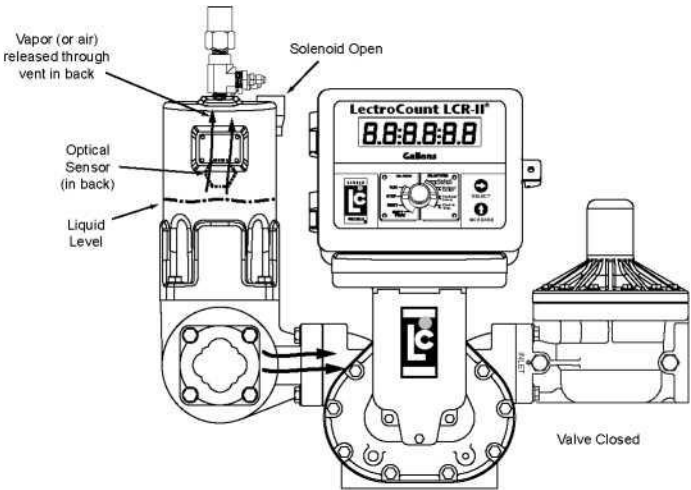

Figure 1: Liquid Level below Optical Sensor

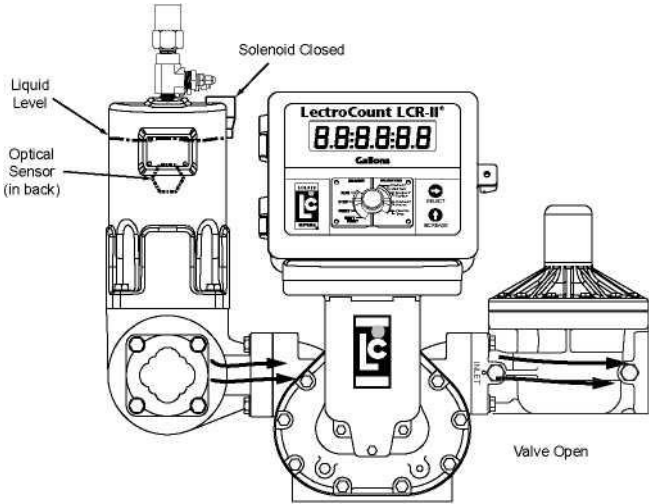

Figure 2: Liquid Level at or above Optical Sensor

INTRODUCTION

How the Optical Vapor Eliminator Works

The figures to the right show a cutaway view of the vent port through the solenoid valve.

When the liquid level is below the sensor, the S3 solenoid valve opens and allows vapor through to the vent port (Figure 4). When the liquid level is at or above the optical sensor, the S3 solenoid valve closes the vent path (Figure 5).

The diagram in Figure 6 shows the LectroCount® register logic for a preset delivery. In order to function properly, the optical vapor eliminator must be used in conjunction with a solenoid actuated control valve at the meter outlet.

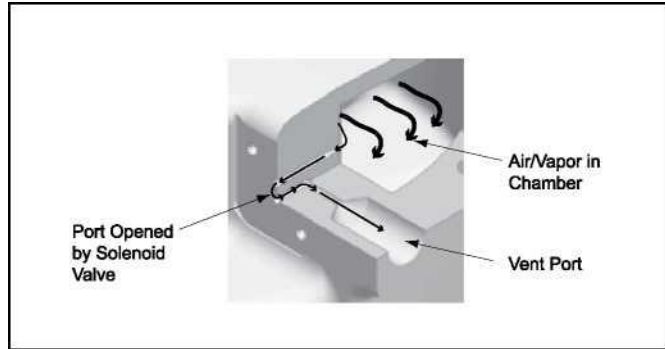

Figure 4: Solenoid and Port Open

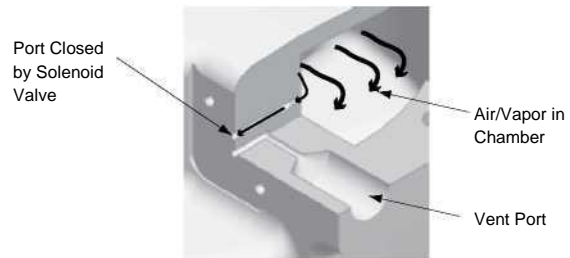

Figure 5: Solenoid and Port Closed

Optical Vapor Eliminator	Initiate		
	Deliver	Open (ON)	ry
	Solenoid 3	1	11 11 End of delivery. 11 Solenoid not active (closed)
		Closed (OFF)	J J
		Fluid Level At or Above Sensor	11 End of delivery.
	Optical Sensor	1 Fluid Below (Level Rising)	11
Two-Stage Valve	1	Solenoid ON	ii 11 11
	Solenoid 1 Solenoid OFF		Solenoid OFF 11
	Solenoid 2 Solenoid OFF		Solenoid ON Solenoid OFF
Product Flow Through the Meter	Full Flow		Solenoid ZERO Shut is Self Adjusting
	No Flow		No Flow

Figure 6: Optical Vapor Eliminator Operating Sequence

INSTALLATION

TOP

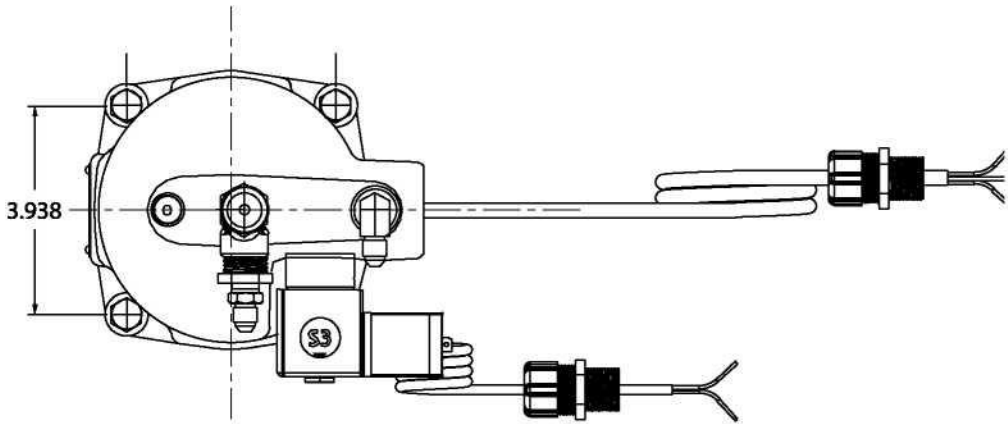

REAR

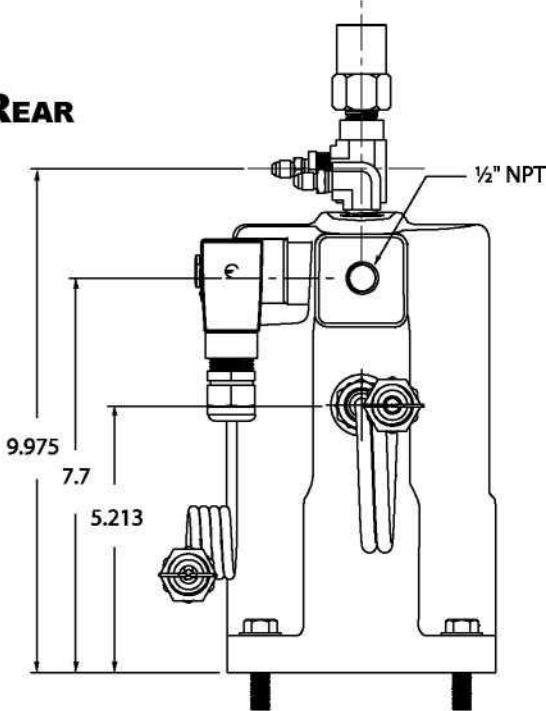

SIDE

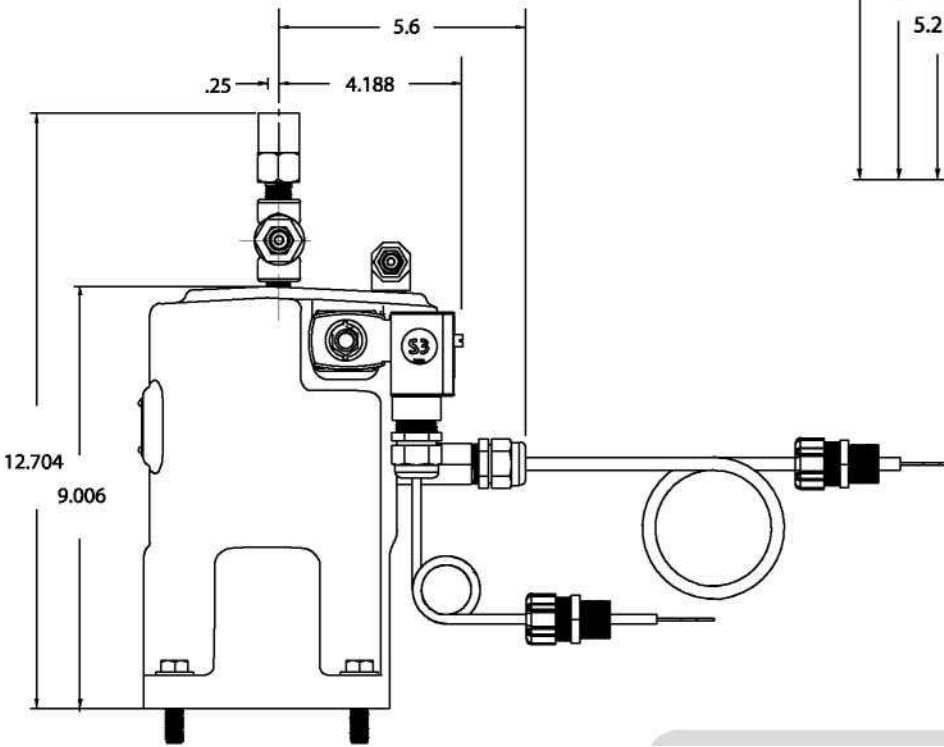

Dimensions shown are not for construction use.
Consult factory when certified engineering drawings are required.

INSTALLATION

New Installations

When ordered with a new meter, the optical vapor eliminator is supplied mounted on top of a strainer on the inlet side of the meter. An example is shown in the figure to the right.

Vent line must be connected from the output port of the optical vapor eliminator to a supply or storage tank. This connection is 1/2" NPT. The vent line must be connected to the supply or storage tank.

The optical vapor eliminator solenoid valve and optical sensor are shipped pre-wired to the LectroCount® electronic register.

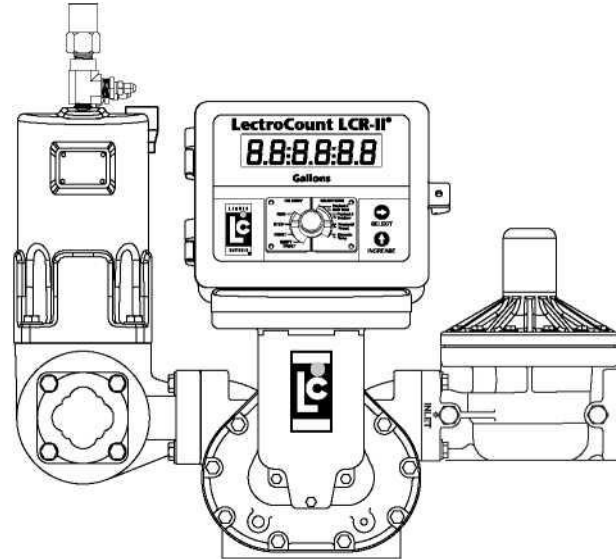

Figure 7: New Assembly

Retrofit Installations

Depending on the existing configuration, adding an optical vapor eliminator valve may require modification of the vent piping, modification or change of the outlet valve, and modification or change of the register.

The optical vapor eliminator requires the following components to operate:

- LectroCount® LCR/LCR-II electronic register with internal CPU board 81920 or 84040, LC³ with CPU board 81924, or LCR 600 with CPU board 84040
- Electronically controlled outlet valve

Refer to the manuals accompanying these components for proper installation and configuration.

J WARNING

RELIEVING INTERNAL PRESSURE

All internal pressure must be relieved to zero pressure before disassembly or inspection of the strainer, vapor eliminator any valves in the system, the packing gland, and the front or rear covers.

SERIOUS INJURY OR DEATH FROM FIRE OR EXPLOSION COULD RESULT IN PERFORMING MAINTENANCE ON AN IMPROPERLY DEPRESSURIZED AND EVACUATED SYSTEM.

Relieving Internal Pressure Procedure for LPG and NH₃ Meters

1.	Close the belly valve of the supply tank.	6.	Slowly crack the fitting on top of the differential valve to relieve product pressure in the system.
2.	Close the valve on the vapor return line.		
3.	Close the manual valve in the supply line on the inlet side of the meter. If no manual valve exists on the inlet side, consult the truck manufacturer for procedures to depressurize the system.		Product will drain from the meter system.
4.	Slowly open the valve/nozzle at the end of the supply line.	7.	As product is bleeding from the differential valve, slowly reopen and close the valve/nozzle on the discharge line. Repeat this step until the product stops draining from the differential valve and discharge line valve/nozzle.
5.	After product has bled off, close the valve/nozzle at the end of the supply line.	8.	Leave the discharge line valve/nozzle open while working on the system.

INSTALLATION

Retrofit Installations

To retrofit an optical vapor eliminator:

1. Remove Old Vapor Eliminator and Baffle Cup

After the internal pressure has been relieved from the system and the assembly drained of liquid, remove the four bolts and washers used to fasten the vapor eliminator to the top of the strainer. Inspect the O-ring and replace if necessary.

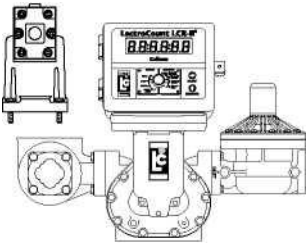

Figure 8: Remove old Vapor Eliminator

2. Mount the Optical Vapor Eliminator

Depending on strainer being used, the optical vapor eliminator may be fastened to the strainer/vapor eliminator in any of four 90° rotational increments. Select the most suitable orientation for the final installation of wiring and vent piping.

Fasten the optical vapor eliminator to the strainer using the four bolts and washers. Tighten the bolts to a torque of 27 lb-ft (37 Nm).

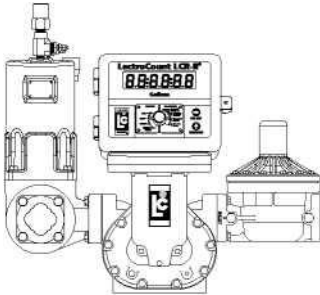

Figure 9: Orient and Fasten the Optical Vapor Eliminator

3. Connect the Control Piping/Tubing for LPG

Make plumbing connections from the 3-way solenoid valve assembly to vapor eliminator and differential valve assembly. Follow the lettered designations in Figure 10.

4. Wire the Solenoid and Sensor to the Register

Wiring instructions begin on Page 10.

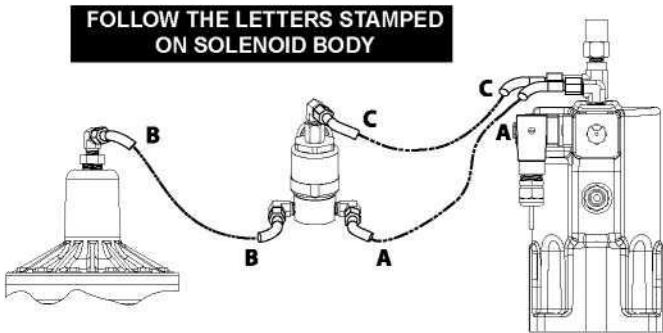

Figure 10: LPG Plumbing Connections

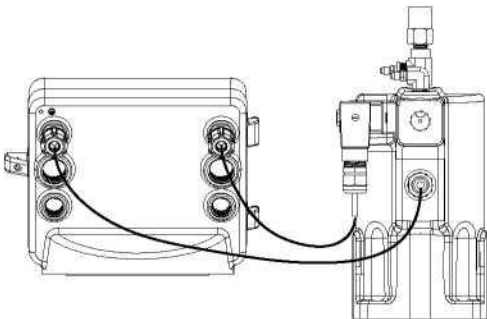

Figure 11: Optical Sensor and Solenoid Valve

INSTALLATION

Wiring

The electrical installation of the optical vapor eliminator includes connecting the S3 solenoid and the optical sensor to the LectroCount register.

The optical sensor has a 24" cable potted to the inside the optical sensor assembly at one end. The other end of the cable has a threaded cord grip that fastens into the back of the LectroCount® register.

The S3 solenoid-operated valve requires a 12 AWG, two-wire, braided cable, approximately 24 to 36" in length.

The S3 solenoid-operated valve requires a LectroCount® LCR/LCR-II electronic register with CPU board part number 81920 or 84040 (LC³ with 81924). If the LectroCount® does not contain a proper CPU board (LC³ with 81924), replacement CPU boards can be ordered.

The 81920 and 84040 CPU board has an additional terminal, J15 (J11 on the LC³ 81924 CPU board). The extra terminal vital for operating the optical vapor eliminator, and it is not present on other board models.

To wire the S3 solenoid and the optical sensor:

1. Remove Cable Plug

Loosen and remove the screw from the cover of the S3 solenoid valve cable plug. Remove the cable plug from the solenoid valve coil. Remove the cover from the cable plug housing and then remove the terminal block. Be sure to note its orientation in the housing. Leave the flat gasket in place on the coil.

2. Connect Cable to Cable Plug

Route one end of the cable through the conduit fitting and into the cable plug housing. Connect the cable wires to the terminal block. Connect the BLACK wire to Terminal 2 and the RED wire to Terminal 1. The terminals are indicated by a small "1" and "2" raised plastic.

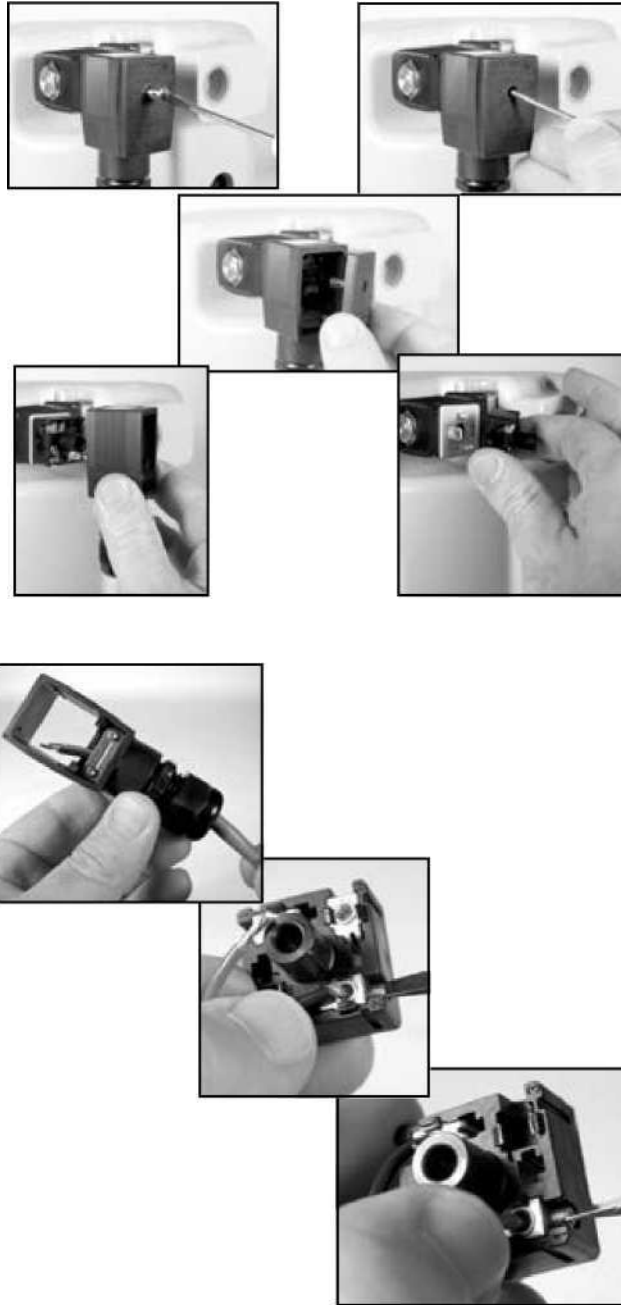

⚠ Caution

Incorrect wiring can damage the optical sensor and the LectroCount® register.



For North American Installations, the installation must be fully in accordance with the National Electrical Code (US) or the Canadian Electrical Code respectively.

INSTALLATION

Wiring

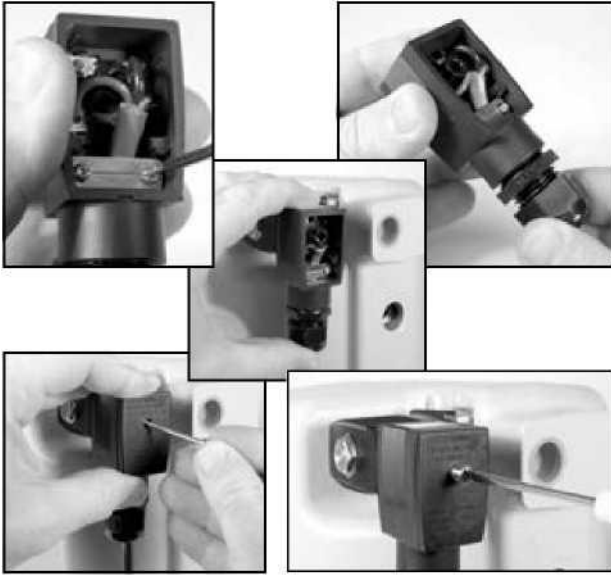

3. Reassemble Cable Plug

Reinstall the terminal block into the cable plug housing to its original orientation. Tighten the strain relief strap inside the cable plug using the two screws. Tighten the cable gland on the bottom of the cable plug so that it seals around the cable.

Reconnect the cable plug to the coil. Place the cover over the cable plug and fasten with the screw to a torque of 8.8 in-lbs (1 Nm).

4. Connect to LectroCount® Electronic Register

Route the cables from the optical sensor and solenoid valve to the back of the LectroCount® register. Connect these to two open ports on the back of the register using the appropriate connectors.

LC³ Wiring

Optical Sensor Connection

Wire Color J11 Pin Connection

Red	33
White	34
Black	35

S3 Solenoid Connection

Terminal J11 Pin Connection

1	(Red)	31
2	(Black)	32

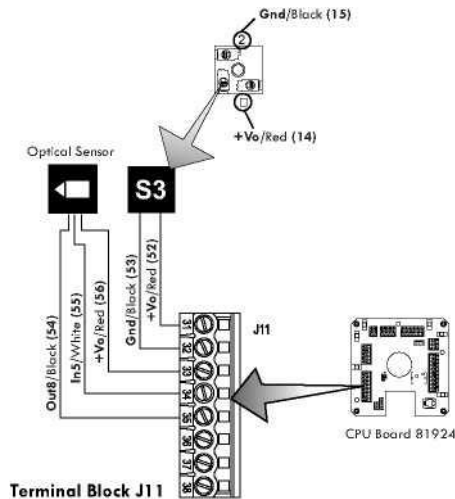

LCR Wiring

Optical Sensor Connection

Wire Color J15 Pin Connection

Red	56
White	55
Black	54

S3 Solenoid Connection

Terminal J15 Pin Connection

1	(Red)	52
2	(Black)	53

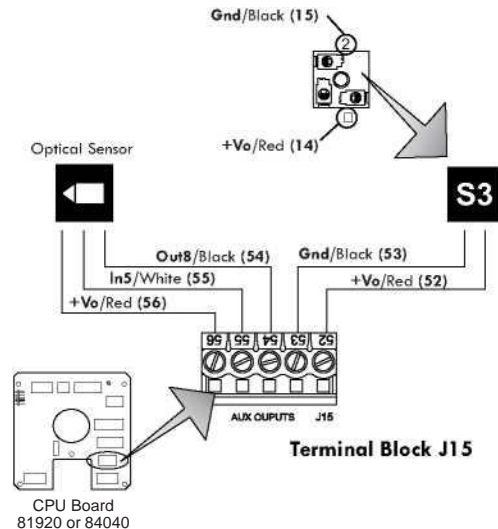

MAINTENANCE

WARNING

Before disassembly of any meter or accessory component, **ALL INTERNAL PRESSURES MUST BE RELIEVED AND ALL LIQUID DRAINED FROM THE SYSTEM IN ACCORDANCE WITH ALL APPLICABLE PROCEDURES.** Pressure must be 0 (zero) psi. Close all liquid and vapor lines between the meter and liquid source.

Failure to follow this warning could result in property damage, personal injury, or death from fire and/or explosion, type of

Disassembly

The optical vapor eliminator consists of a housing, an optical sensor, and a solenoid-operated control valve. Of these three components, only the solenoid valve is serviceable; however, if any part of the solenoid is damaged, a new solenoid assembly (PN 502011) can be ordered. The optical sensor contains no serviceable parts because the internal components are potted. If the optical sensor fails, the complete assembly must be replaced (PN 81947).

To disassemble the S3 solenoid:

1. Loosen the thin hex nut holding the solenoid in place using a 14 mm wrench. Remove the nut and coil from the armature guide post.
2. Remove the plastic bonnet from the armature guide post.
3. Using a screwdriver, loosen the upper left and lower right screws of the valve body. These two screws hold the valve body in place. The upper right and lower left screws fasten the armature guide post and valve body together. Remove the valve body from the optical vapor eliminator housing.
4. Place the valve body on a flat surface. Using a flat blade screwdriver, remove the two screws which hold the armature guide post and valve body together. Lift the armature guide post off of the valve body. There is a plunger and a spring inside the guide post. Inspect the spring for damage.

Tools required:

- Flat blade screwdriver
- 14 mm box end or open end wrench



MAINTENANCE

Disassembly (conf.)

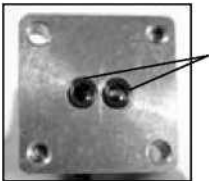
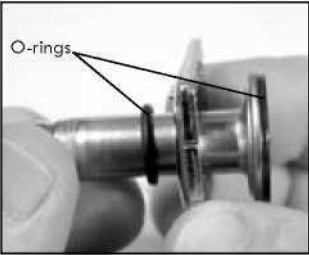

5. The armature guide post is composed of four components: two O-rings, the guide post, and the flange. Inspect these components for damage.

6. The valve body has two O-rings found on the face that butt against the housing. The two O-rings are identical. Inspect them for damage. Inspect the ports for blockage.



Reassembly

1. Place the spring inside the plunger and insert the plunger, spring end first, into the armature guide post. Place the armature guide post assembly on the valve body.

Fasten the armature guide post to the valve body. Two holes of the valve body are threaded and two are not. Screw the proper two screws into the threaded holes

Position solenoid valve body with number stamp in this location

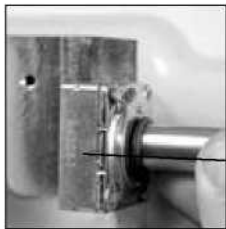
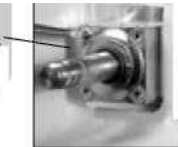

Number Stamp

2. Align the solenoid valve body so that the stamped number on the valve body faces in towards the housing assembly (shown in the pictures to the right). The valve body can physically be fastened to the housing assembly in one of two orientations. Only one orientation is correct.

With the valve body in the proper orientation, fasten it to the housing. Tighten to a torque of 15 to 18 in-lbs (1.7 to 2.0 Nm).

IMPORTANT!

If the stamped numbers face away from the housing, the optical vapor eliminator will not function properly. The port will never open.



3. Place the plastic bonnet over the valve body and snap in place.

4. Place the coil over the armature guide post and fasten with the thin hex nut. Tighten the nut with a 14mm wrench to a torque of 4.5 in-lbs (0.5 Nm).

MAINTENANCE

A WARNING

Before disassembly of any meter or accessory component, **ALL INTERNAL PRESSURES MUST BE RELIEVED AND ALL LIQUID DRAINED FROM THE SYSTEM IN ACCORDANCE WITH ALL APPLICABLE PROCEDURES.** Pressure must be 0 (zero) psi. Close all liquid and vapor lines between the meter and liquid source.

Failure to follow this warning could result in property damage, personal injury, or death from fire and/or explosion, or other hazards that may be associated with this type of equipment.

Optical Sensor

To replace the optical sensor (PN 81947):

1. Drain the system and relieve all internal pressures.
2. Use a 1" open end wrench to remove the optical sensor from the housing.
3. Replace with new optical sensor. When tightening, do not exceed a torque of 75 in-lbs (8.5 Nm).



A light coating of grease or anti-seize lubricant should be applied to the threads of the sensor prior to assembly.

Troubleshooting

Excessive liquid flowing out of vent to supply or storage tank.

SCENARIO 1: Solenoid not closing.

1. Check S3 solenoid wiring.
2. Measure resistance across S3 solenoid. It should read approximately 15 Q. If not, replace S3 solenoid.
3. Inspect S3 solenoid for blockage. *Refer to disassembly instructions.*
4. LectroCount® CPU failure. Replace CPU board.

SCENARIO 2: Optical sensor not functioning.

1. Check optical sensor wiring.
2. Measure resistance between the RED and WHITE wires. Value should be approximately 10kQ. If not, replace optical sensor.
3. LectroCount® CPU failure. Replace CPU board.

Liquid not flowing through meter during delivery.

SCENARIO 1: Liquid level not rising in optical vapor eliminator.

1. Check S3 solenoid. It may not be opening to allow air/vapor to vent.
2. Check S3 solenoid wiring.
3. Measure resistance across S3 solenoid. It should read approximately 15 Q. If not, replace S3 solenoid.
4. Inspect S3 solenoid for blockage. *Refer to disassembly instructions.*
5. LectroCount® CPU failure. Replace CPU board.

SCENARIO 2: Meter outlet valve not opening

1. Check wiring of the outlet valve S1 solenoid.
2. Measure resistance across S1 solenoid. Value should read approximately 15Q. If not, replace S1 solenoid.
3. Inspect S1 solenoid for blockage. *Refer to the manual that accompanies the valve.*
4. LectroCount® CPU failure. Replace CPU board.

BILL OF MATERIALS - EXPLODED VIEW

A8302 Optical Vapor Eliminator (LPG)

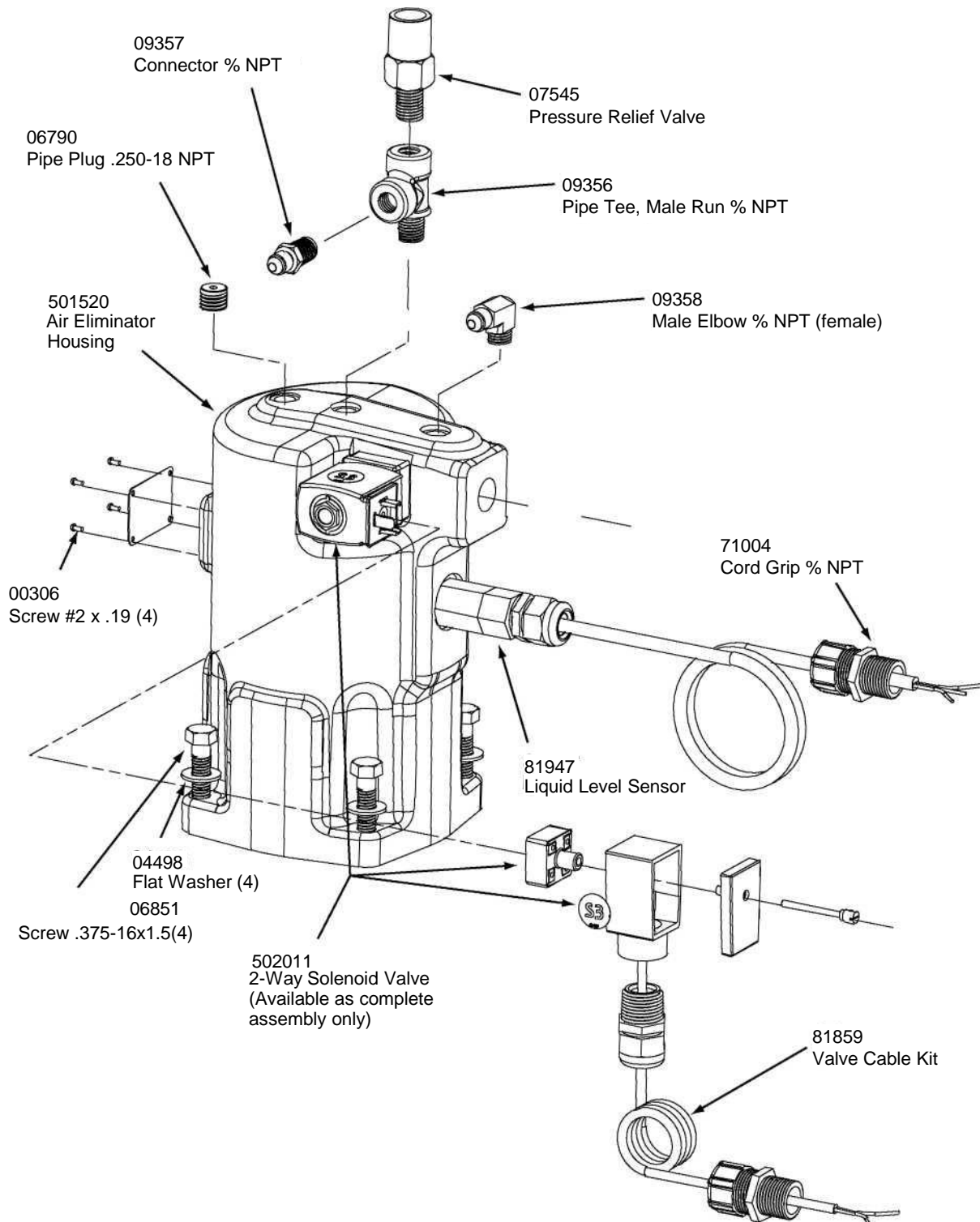

LIQUID CONTROLS

ENERGY & FUELS

* CORKEN • FAUHE HERMAN • SAMPI • SPONSLER • TOPTECH SYSTEMS

Алматы (7273)495-231
Ангарск (3955)60-70-56
Архангельск (8182)63-90-72
Астрахань (8512)99-46-04
Барнаул (3852)73-04-60
Белгород (4722)40-23-64
Благовещенск (4162)22-76-07
Брянск (4832)59-03-52
Владивосток (423)249-28-31
Владикавказ (8672)28-90-48
Владимир (4922)49-43-18
Волгоград (844)278-03-48
Вологда (8172)26-41-59
Воронеж (473)204-51-73
Екатеринбург (343)384-55-89
Иваново (4932)77-34-06

Ижевск (3412)26-03-58
Иркутск (395)279-98-46
Казань (843)206-01-48
Калининград (4012)72-03-81
Калуга (4842)92-23-67
Кемерово (3842)65-04-62
Киров (8332)68-02-04
Коломна (4966)23-41-49
Кострома (4942)77-07-48
Краснодар (861)203-40-90
Красноярск (391)204-63-61
Курган (3522)50-90-47
Курск (4712)77-13-04
Липецк (4742)52-20-81
Магнитогорск (3519)55-03-13

Россия +7(495)268-04-70

Москва (495)268-04-70
Мурманск (8152)59-64-93
Набережные Челны (8552)20-53-41
Нижний Новгород (831)429-08-12
Новокузнецк (3843)20-46-81
Новосибирск (383)227-86-73
Ноябрьск (3496)41-32-12
Омск (3812)21-46-40
Орел (4862)44-53-42
Оренбург (3532)37-68-04
Пенза (8412)22-31-16
Пермь (342)205-81-47
Петрозаводск (8142)55-98-37
Псков (8112)59-10-37

Казахстан +7(7172)727-132

Ростов-на-Дону (863)308-18-15
Рязань (4912)46-61-64
Самара (846)206-03-16
Санкт-Петербург (812)309-46-40
Саранск (8342)22-96-24
Саратов (845)249-38-78
Севастополь (8692)22-31-93
Симферополь (3652)67-13-56
Смоленск (4812)29-41-54
Сочи (862)225-72-31
Ставрополь (8652)20-65-13
Сургут (3462)77-98-35
Сыктывкар (8212)25-95-17
Тамбов (4752)50-40-97

Киргизия +996(312)96-26-47

Тверь (4822)63-31-35
Тольятти (8482)63-91-07
Томск (3822)98-41-53
Тула (4872)33-79-87
Тюмень (3452)66-21-18
Улан-Удэ (3012)59-97-51
Ульяновск (8422)24-23-59
Уфа (347)229-48-12
Хабаровск (4212)92-98-04
Чебоксары (8352)28-53-07
Челябинск (351)202-03-61
Череповец (8202)49-02-64
Чита (3022)38-34-83
Якутск (4112)23-90-97
Ярославль (4852)69-52-93