

Алматы (7273)495-231
Ангарск (3955)60-70-56
Архангельск (8182)63-90-72
Астрахань (8512)99-46-04
Барнаул (3852)73-04-60
Белгород (4722)40-23-64
Благовещенск (4162)22-76-07
Брянск (4832)59-03-52
Владивосток (423)249-28-31
Владикавказ (8672)28-90-48
Владимир (4922)49-43-18
Волгоград (844)278-03-48
Вологда (8172)26-41-59
Воронеж (473)204-51-73
Екатеринбург (343)384-55-89
Иваново (4932)77-34-06

Ижевск (3412)26-03-58
Иркутск (395)279-98-46
Казань (843)206-01-48
Калининград (4012)72-03-81
Калуга (4842)92-23-67
Кемерово (3842)65-04-62
Киров (8332)68-02-04
Коломна (4966)23-41-49
Кострома (4942)77-07-48
Краснодар (861)203-40-90
Красноярск (391)204-63-61
Курган (3522)50-90-47
Курск (4712)77-13-04
Липецк (4742)52-20-81
Магнитогорск (3519)55-03-13

Россия +7(495)268-04-70

Москва (495)268-04-70
Мурманск (8152)59-64-93
Набережные Челны (8552)20-53-41
Нижний Новгород (831)429-08-12
Новокузнецк (3843)20-46-81
Новосибирск (383)227-86-73
Ноябрьск (3496)41-32-12
Омск (3812)21-46-40
Орел (4862)44-53-42
Оренбург (3532)37-68-04
Пенза (8412)22-31-16
Пермь (342)205-81-47
Петрозаводск (8142)55-98-37
Псков (8112)59-10-37

Казахстан +7(7172)727-132

Ростов-на-Дону (863)308-18-15
Рязань (4912)46-61-64
Самара (846)206-03-16
Санкт-Петербург (812)309-46-40
Саранск (8342)22-96-24
Саратов (845)249-38-78
Севастополь (8692)22-31-93
Симферополь (3652)67-13-56
Смоленск (4812)29-41-54
Сочи (862)225-72-31
Ставрополь (8652)20-65-13
Сургут (3462)77-98-35
Сыктывкар (8212)25-95-17
Тамбов (4752)50-40-97

Киргизия +996(312)96-26-47

Тверь (4822)63-31-35
Тольятти (8482)63-91-07
Томск (3822)98-41-53
Тула (4872)33-79-87
Тюмень (3452)66-21-18
Улан-Удэ (3012)59-97-51
Ульяновск (8422)24-23-59
Уфа (347)229-48-12
Хабаровск (4212)92-98-04
Чебоксары (8352)28-53-07
Челябинск (351)202-03-61
Череповец (8202)49-02-64
Чита (3022)38-34-83
Якутск (4112)23-90-97
Ярославль (4852)69-52-93

crn@nt-rt.ru || <https://lcmeter.nt-rt.ru/>



V-7 Valves

Installation and Parts



LIQUID CONTROLS™
An IDEX Energy & Fuels Business

TABLE OF CONTENTS

Description	Page Number
General Information.....	2
Application Class Description	2
Specifications.....	3
How V-7 Valves Work	3
Accessories	4
New Installations	5
Retrofit Installations.....	5-7
Setting the Dwell	8
Setting Zero Shut-off.....	9
Disassembling	10-11
Reassembling.....	11
Illustrated Parts Breakdown	12-15



WARNING

- Before using this product, read and understand the instructions.
- Save these instructions for future reference.
- All work must be performed by qualified personnel trained in the proper application, installation, and maintenance of equipment and/or systems in accordance with all applicable codes and ordinances.
- Failure to follow the instructions set forth in this publication could result in property damage, personal injury, or death from fire and/or explosion, or other hazards that may be associated with this type of equipment.

PUBLICATION UPDATES AND TRANSLATIONS

The most current English versions of all Liquid Controls publications are available on our website. com. It is the responsibility of the Local Distributor to provide the most current version of LC Manuals, Instructions, and Specification Sheets in the required

language of the country, or the language of the end user to which the products are shipping. If there are questions about the language of any LC Manuals, Instructions, or Specification Sheets, please contact your Local Distributor.

GENERAL INFORMATION

Liquid Controls V-7 Valves are designed for a wide range of applications and flow rates and have minimum pressure loss. Careful engineering and construction ensure smooth, accurate, and controlled operation.

The V-7 Series mechanically-actuated piston valves are available in 1 1/2" and 2" sizes, and are designed for mounting on the meter outlet to provide tight shut-off with smooth and easy operation regardless of system line pressure. The valves may be manually operated or connected via a mechanical linkage to a preset counter on the meter for single-stage closure (for low flow applications) or two-stage closure with dwell period to eliminate hydraulic shock. The valves are indexible in 90° increments for up, down, or side facing outlet.

V-7 Series valves offer the important advantage of a pressure-balanced dashpot design that ensures precise valve response and soft closure at shut-off. Operation is smooth and easy regardless of the line pressure, since the vector forces are directed at right angles to the valve opening mechanism and are never in opposition to it.

Depending on the preset, the valve may be operated as either a two-stage valve with dwell period shut-off, or as a single-stage valve with abrupt shut-off. Single stage valves are recommended when the application flow rates are low.

Applications Class Description	Class Number
Refined petroleum products	1
Aviation and jet fuel	2
Variety of products including: liquid sugars, sweeteners, syrups, & vegetable oils	3
Treated waters & solvents where no red metals are allowed	4
Chlorinated solvents	7
Acidic pH liquids including: nitric, phosphoric, glacial acetic acids, citric juices, & vinegar	8
Crude Oil	14
Oil-based & Water-bases latex products, polyester, resins, herbicides, & nitrogen fertilizers	15
General Solvents, 200 proof alcohol	16
Batch process water meter service	20
Alkaline pH Liquids including: latex products, adhesives, & liquid fertilizers	27
Herbicides	30
Sodium Hydroxide solutions, high sulfur crude oil, & alkaline pH liquids	37

SPECIFICATIONS

Model	Body & Seal Material	Companion Flanges	Working Pressure	Application Class*
V-7 (A2600 Series)	Used with M-5, M-7 & M-10 Meters		150 PSI (10.3 BAR)	
A2621	Aluminum with Viton Seal	1½" & 2"	150 PSI (10.3 BAR)	1,2, 14
A2623	Aluminum with Teflon Seal	1½" & 2"	150 PSI (10.3 BAR)	1,2, 3, 4, 14, 15, 16, 30
A2631	Aluminum with Viton Seal	1½" & 2"	150 PSI (10.3 BAR)	1,3, 14, 15
A2651	Aluminum with Viton Seal	1½" & 2"	150 PSI (10.3 BAR)	3, 4, 14, 15, 16
A2652	Aluminum with Buna N Seal	1½" & 2"	150 PSI (10.3 BAR)	1,2, 16, 20
A2655 1	Aluminum with Viton & Teflon Seal	¾" & 2"	150 PSI (10.3 BAR)	1,30
A2684	Brass with Viton Seal	1½" & 2"	150 PSI (10.3 BAR)	20
A2690	Brass with Viton Seal	1" & 2"	150 PSI (10.3 BAR)	20
A2693 1	Brass with Teflon Seal	¾" & 2"	150 PSI (10.3 BAR)	20
A2670	Cast Iron with Viton Seal	1" & 2"	150 PSI (10.3 BAR)	7, 37
A2671	Cast Iron with Teflon Seal	1" & 2"	150 PSI (10.3 BAR)	7, 27
A2672	Cast Iron with Viton Seal	1" & 2"	150 PSI (10.3 BAR)	7, 27, 37
A2681	Stainless Steel with Viton Seal	1" & 2"	150 PSI (10.3 BAR)	8
A2682	Stainless Steel with Teflon Seal	1" & 2"	150 PSI (10.3 BAR)	8

HOW V-7 VALVES WORK

Inside the valve housing, a cylindrical bore connects the valve inlet and outlet. Contained within the bore is a piston assembly. Measured liquid exiting the meter outlet is blocked from entering the valve inlet by the piston and seal.

As the meter operator shifts the handle to the open position, a mechanical linkage connecting the valve to the preset counter trip ring causes a latch to engage and hold the valve open allowing liquid to flow.

In the open position, the valve handle assembly compresses the piston spring and pulls the piston shaft and the piston away from the valve inlet. As the piston is pulled away, it disconnects from the inlet seal, allowing liquid to flow.

In most metering applications, closing the valve is a two-stage process. At a predetermined dwell period, the preset counter, while counting down to "0", releases a latch mechanism, allowing the valve linkage to close to approximately 10% of full flow. This initial closing causes the piston inside the valve to slide toward the inlet, restricting product flow.

As liquid is blocked by the piston, some product passes through the dashpot washer bleed holes, creating the hydraulic balance feature of V-7 Valves that allows the valve to close slowly and smoothly. The dwell period prevents hydraulic shock while permitting the preset counter to register the remaining flow.

As the preset counter reaches "0", the preset counter trip ring disengages from the dwell position to the fully closed position. This action releases the valve handle and relaxes the piston spring, permitting the piston to contact the inlet ring seal and complete its closure,

stopping product flow. This process is illustrated in Figure 2.

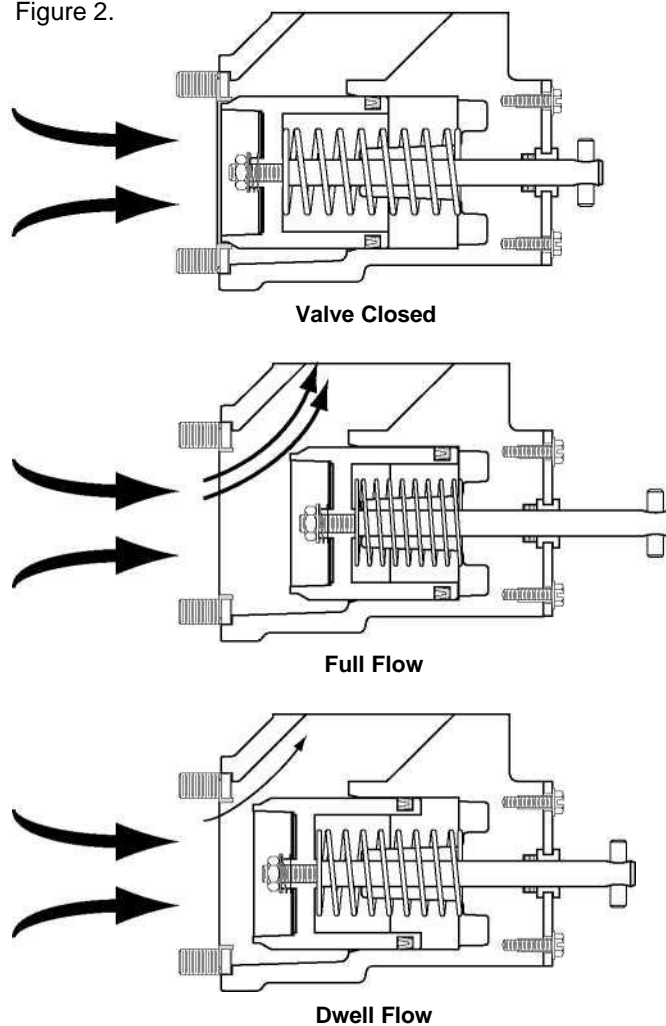

Figure 2: Valve Operation

V-7 VALVES



Figure 3a: Cast Iron or Aluminum



Figure 3b: Stainless Steel



Figure 3c: Brass

ACCESSORIES

Dashpot Washers

V-7 Valves are offered with a variety of dashpot washers. They are available in either brass or stainless steel construction material. Four different bleed orifice configurations (Figure 4) are available to ensure proper closure regardless of viscosity. For viscosities greater than 20,000 SSU, do not use a dashpot washer.

Flanges

Flanges (Figure 5) are offered in 1 1/2 and 2 inch BSPT and NPT sizes and weld types. Materials of construction are aluminum, brass, cast iron, and stainless steel. Teflon, Viton, and Buna seals and gaskets are available.

Linkage and Valve Handles

Valve handle (Figure 6) and linkage assemblies are accessories used when normal manual ON and OFF valve operation is desired. Different handle and linkage configurations can be ordered separately for field installations.

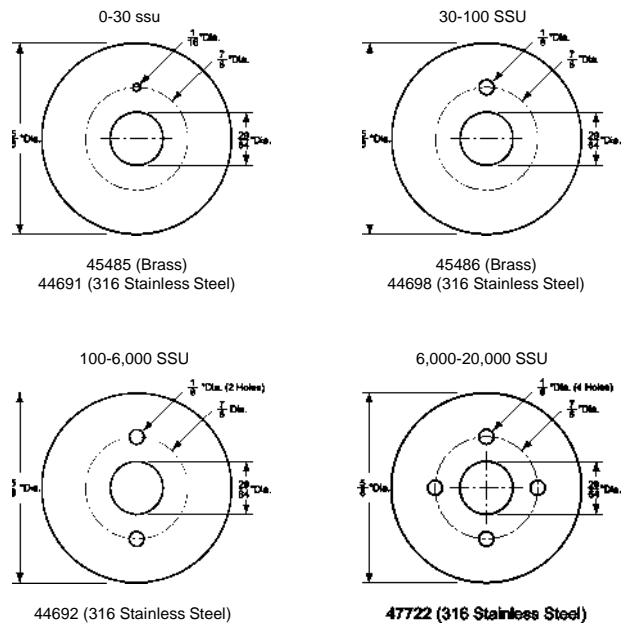

Figure 4: Dashpot Washers



Figure 5: Flanges



Figure 6: Left and Right Valve Handles

V-7 VALVES - INSTALLATION

New Installations

When ordered with a new metering system, the V-7 Series Valve is supplied mounted to the outlet side of the meter as shown to the right. A liquid line must be connected to the flange on the outlet side of the valve or to the accompanying air check valve. The flange connection on the V-7 valve is 1 1/8" or 2" BSPT or NPT or weld type.

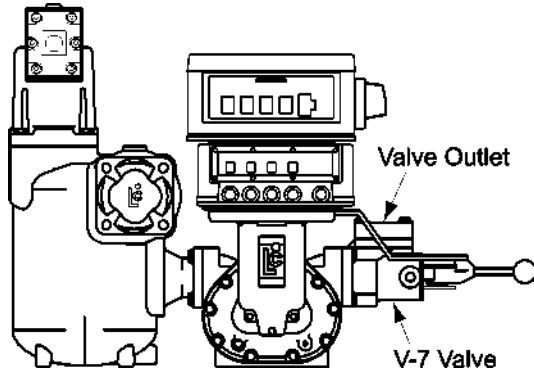

Figure 7: V-7 Valve installed

Retrofit Installations

Depending on the existing configuration, adding a V-7 Valve may require modification of the outlet piping.

After the internal pressure is relieved from the system, the outlet line can be disconnected from the meter. The new valve assembly can then be connected to the outlet side of the positive displacement meter.

Installing the Valve

V-7 valves can be mounted in four possible positions (Figures 8a-8d) depending on the required direction of the valve output. The output can be front or back, top or bottom. Standard valve position is configured with a top outlet connection for flow from left to right and a horizontal handle with an offset linkage assembly.

Positioning the Seal Ring

Each V-7 Valve is supplied with a seal ring. The inner seal lip faces the valve housing and not the meter. Place the seal on the valve and mount the valve to the meter using the four bolts provided. Thread the four bolts into the meter housing but do not tighten.



WARNING Relieve Internal Pressure

- All internal pressure must be relieved to zero pressure before disassembly or inspection of the meter or any of the meter accessories.
- Serious injury or death from fire or explosion could result from maintenance of an improperly depressurized and evacuated system.



Figure 8a:
Standard Top
Facing Outlet



Figure 8b: Rear
Facing Outlet



Figure 8c:
Bottom Facing
Outlet



Figure 8d: Front
Facing Outlet

V-7 VALVES - INSTALLATION

Retrofit Installations (continued)

Attaching the Valve Handle

There are several options for valve handles. Systems which do not use a preset use a faucet valve kit (Part Number A2755).

For systems which use a preset, curved valve handles are offered for left-to-right or right-to-left flow, or a straight handle may be used. The valve handle options are listed in the table below.

1. Line up the hole in the valve handle with the holes in the lift bracket.
2. Insert the valve handle shaft through the lift bracket and valve handle. Secure with one retaining ring on each side of the lift bracket.
3. Insert the roller chain link into the valve shaft and valve handle.
4. Slide the flat link over the ends of the roller chain link. Secure the roller chain link with the retaining clip.

The valve piston should be flush or slightly drawn into the valve to ensure proper installation. Use a screwdriver handle (Figure 10) or a wooden dowel to prop the valve handle in the open position. This action will compress the piston spring, drawing the piston into the housing and allowing the valve to mount flush to the meter. With the valve propped open, tighten the four bolts in crossing pattern.

Figure 11 shows the valve handle mounted two different ways. The valve on the left is opened by pulling on the handle, the valve to the right by pushing on the handle. Regardless of the valve or handle orientation, the link pivot stub must face up in order to properly install the linkage assembly.

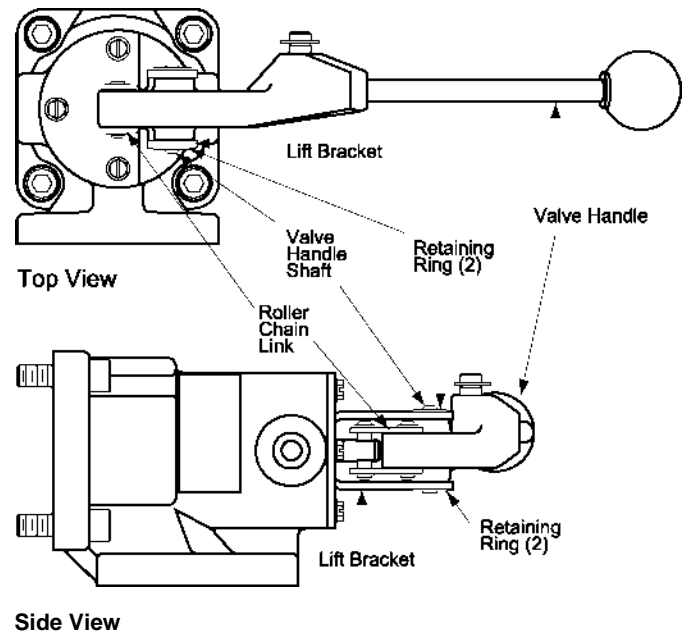

Figure 9: Valve Handle Views



Figure 11: Handle Orientations



Figure 10: Handle Propped Open

V-7 Valve Handles for Aluminum, Brass, & Cast Iron Valves

Part Number	Description
43614	Valve Handle Assembly, Curved, Right-to-Left Flow
43617	Valve Handle Assembly, Curved, Left-to-Right Flow
44685	Valve Handle Assembly, Straight

V-7 Valve Handles for Stainless Steel Valves

Part Number	Description
46335	Valve Handle Assembly, Straight
45336	Valve Handle Assembly, Curved, Right-to-Left Flow
45337	Valve Handle Assembly, Curved, Left-to-Right Flow

V-7 VALVES - INSTALLATION

Installing the Linkage Assembly

Linkage assemblies are used with presets. The linkage provides the connection between the valve handle and the preset trip ring mounted on the mechanical register. The linkage assembly is selected based on the meter/register configuration. Linkage assemblies are available in either straight or offset styles. These are listed in the table below.

1. Mount the linkage assembly to the preset ring by threading the threaded end of the ball joint into the preset ring. Attach the linkage end to the ball joint (Figure 13a).
2. Mount the other end of the linkage assembly to the valve handle. Remove the retaining ring from pivot stud on the valve handle to accomplish this.
3. Place the linkage bracket over onto the pivot stud ensuring that the flat side of the linkage bracket is facing the valve handle (Figures 13b & c). Secure using the retaining ring.

Proceed with setting the dwell.



Figure 12: Linkage Assemblies

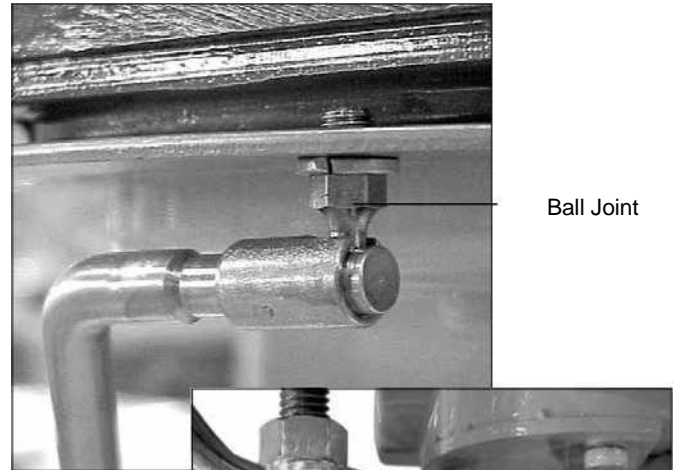

Figure 13a

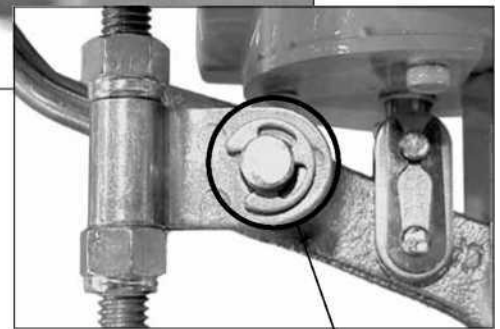

Figure 13b



Figure 13c:

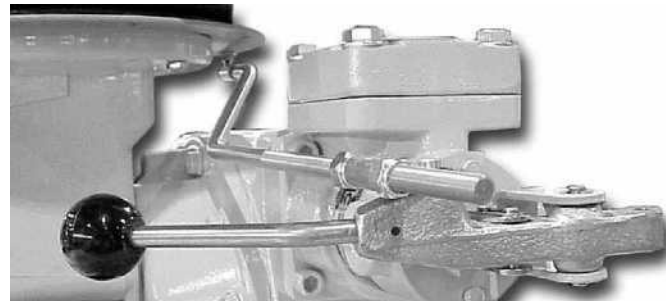

Figure 13d: Linkage Installed

Retaining Ring
& Pivot Stud

V-7 Valve Linkage Assemblies for Aluminum, Brass, & Cast Iron Valves

Part Number	Style	Description
49925	Offset	For use on M-7 meters with TVC & V-R Preset
A2712	Straight	Linkage Assembly for LC Preset
A2714	Offset	Linkage Assembly for LC Preset
A2728	Offset	Right-to-Left Flow with TVC & LC Preset
A2730	Straight	For all Meters with a Counter Extension & LC Preset

V-7 Valve Linkage Assemblies for Stainless Steel Valves

49922	Offset	Stainless Steel for use with M-5 & M-7 Meters with V-R Preset
A2725	Straight	Stainless Steel Linkage Assembly for LC Preset
A2726	Offset	Stainless Steel Linkage Assembly for LC Preset

V-7 VALVES

Setting the Dwell

Correct linkage adjustments avoid hydraulic shock.

Hydraulic shock occurs when a volume (mass) of liquid moving at a high rate through a pipeline is stopped by a valve that is suddenly closed. When the flow stops abruptly, the mass of liquid acts as a battering ram, causing a shock effect within the metering system. The meter housing and internal parts receive the full impact since the valve is located at the meter outlet. The greater the mass, length of pipeline or velocity, the greater the hydraulic shock and the greater the damage possibilities.

To prevent damage from hydraulic shock, a slow closure, two-stage valve and preset should be used with the meter. In some instances, mass, length of pipeline, or velocity are of such a magnitude that using a two-stage valve is ineffective. In this case, an impact absorbing, air cushioning device should be used as an added accessory.

The linkage between the valve and preset can be adjusted to increase or decrease product flow during the dwell period. To make adjustments shift the valve handle to the slow flow or dwell setting. (See the preset counter manual for more detail).

Turn the two 9/16 inch linkage nuts (Figure 14) located on either side of the bracket to adjust the linkage for proper dwell.

- On a right to left flow meter the nuts are moved to the right to increase dwell flow and moved to the left to decrease dwell flow.
- On a left to right flow meter the opposite is true. Moving the nuts to the right decreases dwell flow and moving nuts to the left increases dwell flow.

While adjusting the nuts, it is important to hold the linkage rod firmly so that it does not move.

Proper adjustment is obtained when the far right wheel of the preset counter (Figure 15) slows to a readable rate and the characteristic dwell hiss is heard. Dwell hiss is a low, resonating sound caused by slow moving product through the valve.

When this is accomplished, tighten the adjusting nuts ensuring that the linkage bracket is free to move, but there is little slop between the linkage bracket and the adjusting nuts.

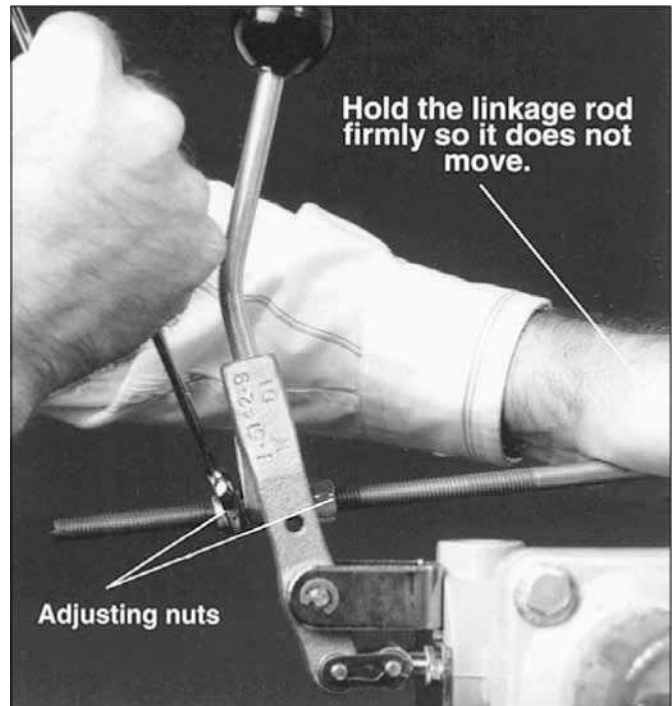

Figure 14: Linkage Adjustment

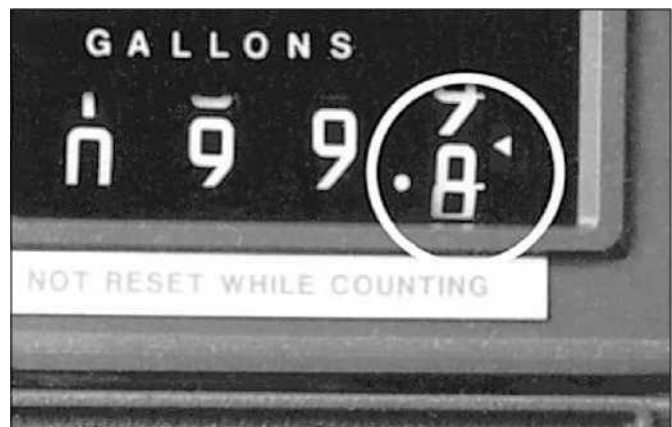

Figure 15: Preset Counter

V-7 VALVES

Adjusting Zero Shut-off (LC Preset)

Because of the interaction between the valve and the preset counter, some adjustment may be needed to the preset counter so that components work at optimum efficiency. Preset Counters assembled with meters at the factory are adjusted for proper shut-off timing. Due to meter system variations, such as flow rate and viscosity, it may be necessary to make zero shut-off adjustments.

At least two test runs should be completed before any adjustments are made. On all presets, make a test run using a value large enough to permit the meter to reach its normal flow rate. If it is determined after testing that an error in zero shut-off is indicated, correct the zero shut-off in the following manner.

1. Start by removing the eight screws that hold the bezel to the preset counter.
2. Remove the bezel (Figure 16a).
3. Press the preset button directly below the units wheel until the set screw appears in the opening.
4. Use a screwdriver to loosen the set screw on the notch ring located on the left side of the units wheel (Figure 16b). This allows for the repositioning of the notch ring and units wheel.

5a. Early Shut-off

To correct an early shut-off, hold the notch ring in place (Figure 16c) and move the numbers wheel down enough to correct the misalignment.

5b. Late Shut-off

To correct a late shut-off, hold the notch ring in place (Figure 16c) and move the numbers wheel up enough to correct the misalignment.

6. After each adjustment, carefully tighten the set screw. Take care not to strip the threads with excessive torque.
7. After running two test runs, the zero should be centered in the window. If not, reset the notch ring and repeat the procedure.
8. Ensure that the set screw is tight and remount the bezel.



Figure 16a: Bezel Removal

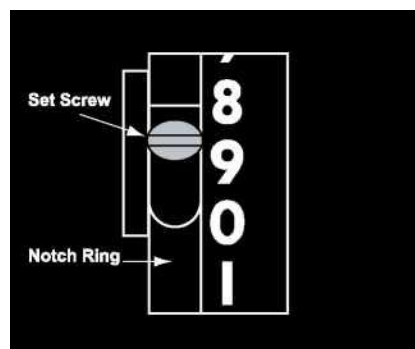

Figure 16b: Set Screw & Notch Ring

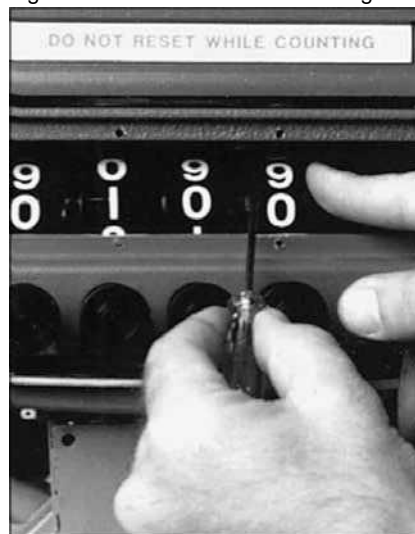

Figure 16c: Set Screw Adjustment

V-7 VALVES

Disassembling the Valve

WARNING

Relieve Internal Pressure

- All internal pressure must be relieved to zero pressure before disassembly or inspection of the meter or any of the meter accessories.
- Serious injury or death from fire or explosion could result from maintenance of an improperly depressurized and evacuated system.



To perform maintenance on a V-7 valve, or to repair a V-7 valve, it must be removed from the meter. Note the orientation of the valve so that it can be replaced in the proper orientation. Drain all the fluid from the metering system prior to valve removal.

1. Remove the four screws and washers holding the valve to the meter.
2. Remove the valve from the piping connection.

NOTE: The valve piston is under pressure exerted by the valve compression spring. Exercise caution when disassembling the valve.

3. Place the valve on a flat surface with the valve piston facing down (Figure 17a).
4. Remove the retaining clip from the connection link. A screwdriver may be needed to pry the retaining clip off (Figure 17b).
5. Press down on the valve housing so that the valve piston is forced into the valve, pushing the valve shaft and handle away from the valve housing.
6. While keeping pressure on the valve, remove the two pieces of the connection link (Figure 17c-d).
7. Slowly release the valve until the compression spring exerts no pressure. As the valve housing is lifted, the piston assembly and compression spring should easily slide out of the housing (Figure 17e). The piston and seals may now be inspected, cleaned and replaced as needed.

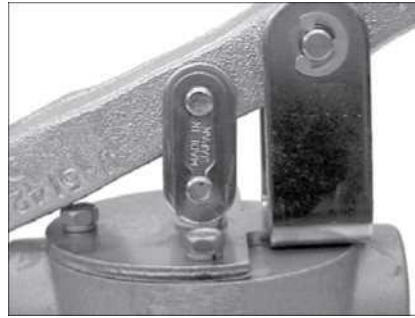

Figure 17a



Figure 17b



Figure 17c



Figure 17d



Figure 17e: Piston Assembly Removed

V-7 VALVES

Disassembling the Valve (continued)

Disassembling the Piston Assembly

8. Use a 7/16" wrench to remove the nut from the valve shaft (Figure 18a).
9. Remove the nut, washer, spring, dashpot washer, and piston from the valve shaft (Figure 18b).

Reassembling the Valve

1. Place the piston on the valve shaft
2. Place the dashpot washer, spring, and washer on the valve shaft and secure by placing the nut on the end of the valve shaft.
3. Place the compression spring into the valve housing.
4. Insert the valve shaft and piston assembly into the valve housing. The piston will rest on the compression spring.
5. Place the assembly on a flat surface with the piston facing down.
6. Press down on the valve housing, compressing the compression spring and forcing the end of the valve shaft to protrude out of the valve housing.
7. While keeping pressure on the valve assembly, insert the link connector through the valve shaft opening and the valve handle opening.
8. When the link connector is completely inserted through these two elements, place the flat end of the link connector over the two studs and secure with the retaining clip.

When reassembly of the V-7 valve is complete, it may be returned to service. Follow the installation instructions which begin on Page 5.



Figure 18a: Piston Assembly

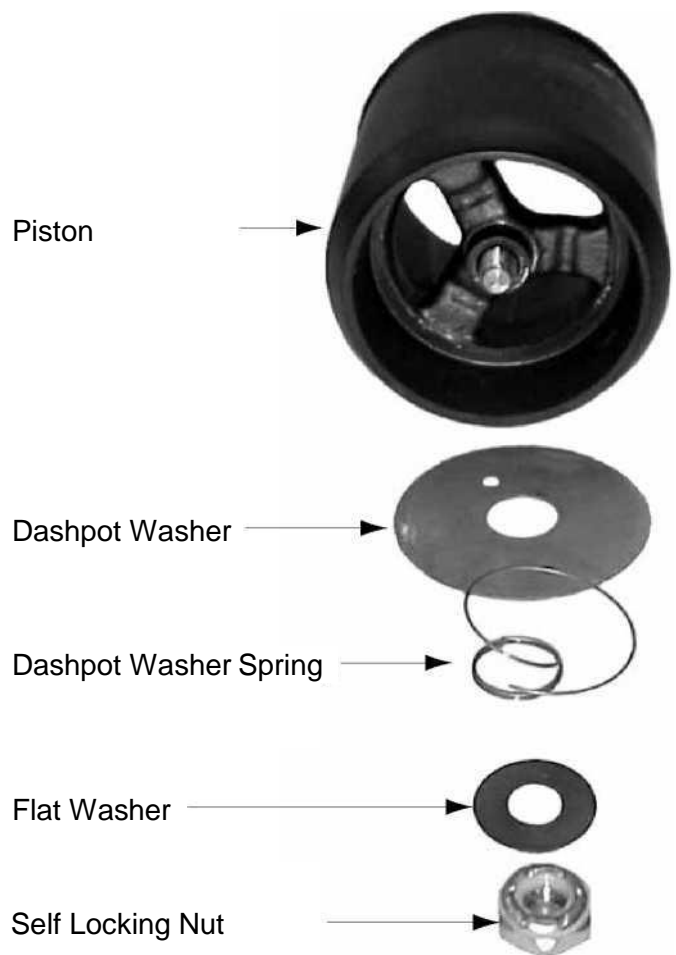
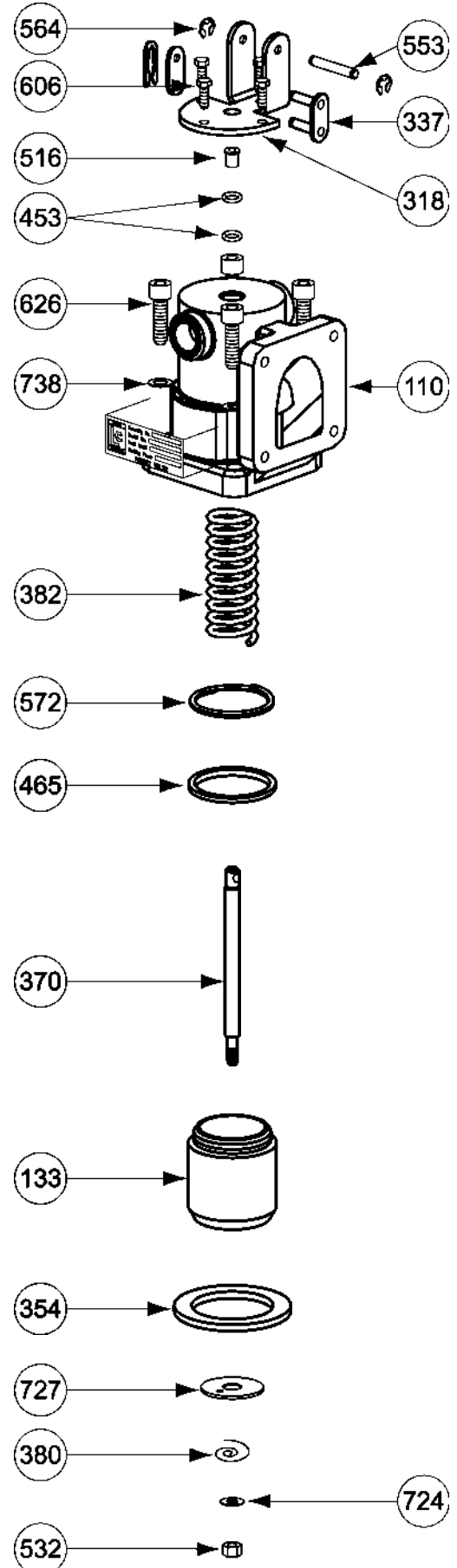

Figure 18b: Piston Assembly Disassembled

ILLUSTRATED PARTS BREAKDOWN - V-7 ALUMINUM VALVES

A2655 Shown

Item No.	Description	Part No.
110	Valve Housing	43605
133	Piston	43607
220	Piston Sub-Assembly	49808
318	Lift Bracket	43652
337	Roller Chain Link	07103
354	Lower Seal Ring	43626
370	Valve Shaft	43612
380	Dashpot Washer Spring	43620
382	Compression Spring	43678
453	O-Ring (2)	09275
465	Quad Ring, Viton	07832
516	Sleeve Bearing	07102
532	Self Locking Nut	06050
553	Valve Handle Shaft	45345
564	Retaining Ring (2)	07304
572	Retaining Ring	06044
606	Screw, #10-24 x .625 (4)	09079
626	Screw, .375-16 x 1.25 (4)	06991
724	Flat Washer	06635
727	Dashpot Washer (See Page 4)	
738	Flat Washer (4)	04607



Model No.	A2621	A2623	A2631	A2651	A2652	A2655
Item No.	Part No.					
110	43605	44695	43605	43605	43605	43605
133	44658	43607	43602	43602	43602	43607
220	N/S	49808	N/S	N/S	N/S	49808
318	43652	43652	43652	43652	43652	43652
337	07103	07103	07103	07103	07103	07103
354	43626	43674	43626	43626	43608	43626
370	43612	43612	43612	43612	43612	43612
380	43620	43620	N/A	43620	43620	43620
382	N/A	43678	43678	43678	43678	43678
388	N/A	06943	N/A	N/A	N/A	N/A
424	N/A	45818	N/A	N/A	N/A	N/A
446	N/A	44696	N/A	N/A	N/A	N/A
453	09275	N/A	09275	09275	07443	09275
465	07822	07832	07253	07253	06848	07832
516	07102	07102	07102	07102	07102	07102
532	06050	06050	06050	06050	06050	06050
553	45345	45345	45345	45345	45345	45345
564	07304	07304	07304	07304	07304	07304
572	N/A	06044	N/A	N/A	N/A	06044
606	09079	09079	09079	09079	09079	09079
626	06991	06991	06991	06991	06991	06991
724	06635	06635	N/A	06635	06635	06635
738	04607	04607	04607	04607	04607	04607
780	N/A	43672	N/A	N/A	N/A	N/A

N/A = Not for Sale

ILLUSTRATED PARTS BREAKDOWN - V-7 BRASS VALVES

A2690 Shown

Item No.	Description	Part No.
110	Valve Housing	45481
133	Piston	45483
220	Piston Sub-Assembly	N/S*
310	Valve Orifice Plate	45099
318	Lift Bracket	43652
337	Roller Chain Link	07103
354	Lower Seal Ring	43626
370	Valve Stem	45484
380	Dashpot Washer Spring	43620
382	Compression Spring	43678
453	O-Ring (2)	09275
465	Quad Ring	07253
516	Sleeve Bearing	07102
532	Stop Nut	07401
553	Valve Handle Shaft	45345
564	Retaining Ring (2)	07304
572	Retaining Ring	07925
606	Screw, #10-24 x .625 (4)	07295
626	Screw, .375-16 x 1.25 (4)	07690
738	Flat Washer (4)	06166
724	Flat Washer	06635

Model No.	A2684	A2690	A2693
Item No.	Part No.		
110	N/S*	45481	N/S
133	45483	45483	45454
220	N/S	N/S	N/S
310	45099	45099	45099
318	43652	43652	43652
337	07103	07103	07103
354	43626	43626	43674
370	45484	45484	45484
380	43620	43620	43620
382	43678	43678	43678
388	N/A	N/A	44696
424	N/A	N/A	45818
446	N/A	N/A	06943
453	09275	09275	N/A
465	07253	07253	07832
516	07102	07102	07102
532	07401	07401	07401
553	45345	45345	45345
564	07304	07304	07304
572	N/A	07925	06044
573	07925	N/A	07925
606	07295	07295	07295
626	07690	07690	07497
738	04607	06166	04607
724	06635	06635	06635

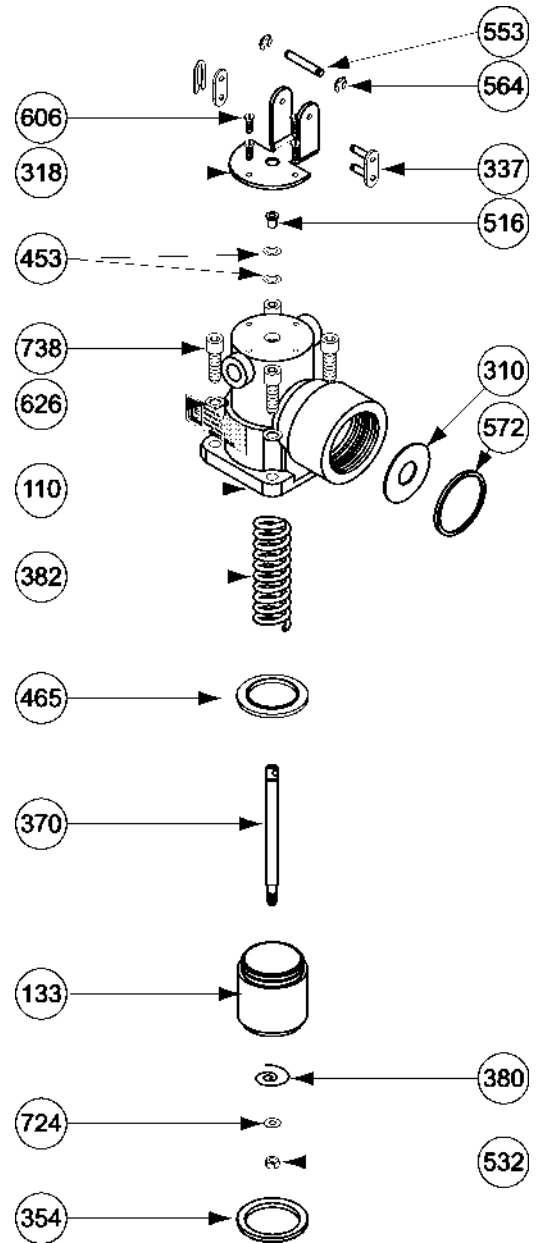

ILLUSTRATED PARTS BREAKDOWN - V-7 CAST IRON VALVES

A2672 Shown

Item No.	Description	Part No.
110	Valve Housing	44689
133	Piston	44690
220	Piston Sub-Assembly	N/S*
318	Lift Bracket	43652
337	Roller Chain Link	07103
354	Lower Seal Ring	43674
370	Valve Shaft	43612
380	Dashpot Washer Spring	43620
382	Compression Spring	43678
388	Compression Spring	44696
424	Flange Gasket	45818
446	V-Ring Seal	06943
465	Seal, Teflon	07832
512	Sleeve Bearing	07464
516	Sleeve Bearing	07102
532	Self Locking Nut	06050
553	Valve Handle Shaft	45345
564	Retaining Ring (2)	07304
572	Retaining Ring	06044
606	Screw, #10-24 x .625 (4)	07295
626	Screw, .375-16 x 1.25 (4)	07319
724	Flat Washer	06635
738	Flat Washer (4)	04607
780	Flat Washer	43672

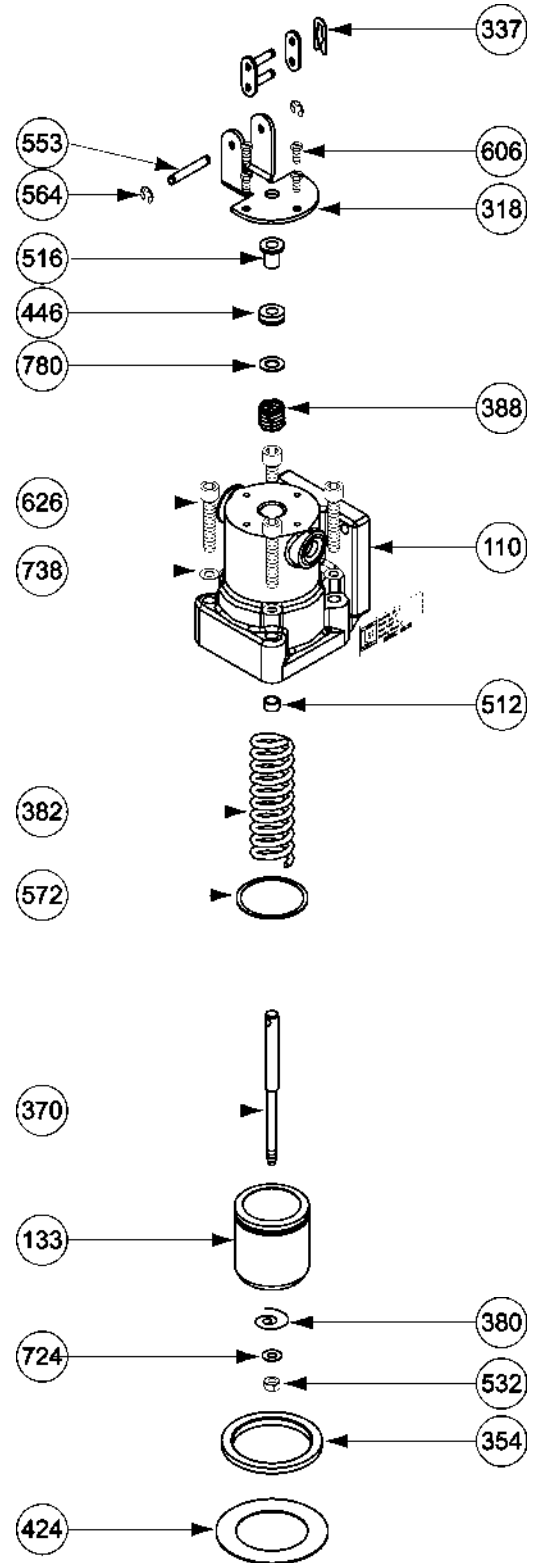

Model No.	A2670	A2671	A2672
Item No.	Part No.		
110	44682	44682	44689
133	44684	44690	44690
220	N/S	N/S	N/S
318	43652	43652	43652
337	07103	07103	07103
354	43626	43626	43674
370	43612	43612	43612
380	43620	43620	43620
382	43678	43678	43678
388	N/A	N/A	44696
424	N/A	N/A	45818
446	N/A	N/A	06943
453	09275	09275	N/A
465	07253	07832	07832
512	07464	07464	07464
516	07102	07102	07102
532	06050	06050	06050
553	45345	45345	45345
564	07304	07304	07304
572	N/A	06044	06044
606	07295	07295	07295
626	07319	07319	07319
724	06635	06635	06635
738	04607	04607	04607
780	N/A	N/A	43672

N/A = Not for Sale

ILLUSTRATED PARTS BREAKDOWN - V-7 STAINLESS STEEL VALVES

A2682 Shown

Item No.	Description	Part No.
133	Piston	48567
208	Valve Housing	N/S*
220	Piston Sub-Assembly	N/S
318	Lift Bracket	45339
337	Roller Chain Link (2)	45342
354	Lower Seal Ring	43626
370	Valve Shaft	48566
380	Dashpot Washer Spring	43620
381	Spacer (2)	45343
382	Compression Spring	43678
383	Bearing	45340
388	Bushing	48565
424	Flange Gasket	45818
446	Seal	09244
461	O-Ring, Teflon	09246
463	O-Ring, Teflon	49881
465	Seal, Teflon	07832
532	Self Locking Nut	06050
550	Valve Shaft (2)	45346
553	Valve Handle Shaft	45345
561	Retaining Ring (4)	07524
564	Retaining Ring (2)	07523
570	Retaining Ring	42606
572	Retaining Ring	06044
606	Screw, #10-24 x .625 (4)	07521
626	Screw, .375-16 x 1.25 (4)	07497
724	Flat Washer	06635
738	Flat Washer (4)	06166
781	Lock Washer (4)	07121

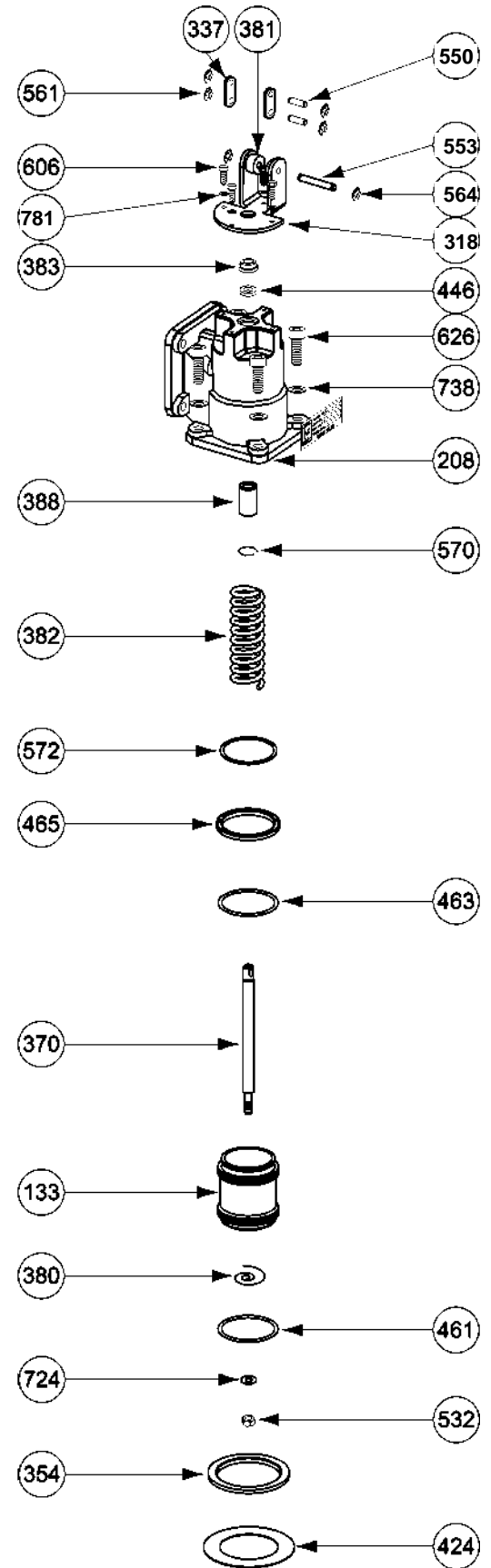

Model No.	A2681	A2682
110	N/S*	N/S
133	48567	48567
208	N/S	N/S
220	N/S	N/S
318	45339	45339
337	45342	45342
354	43626	43674
370	48566	48566
380	43620	43620
381	45343	45343
382	43678	43678
383	45340	45340
388	48565	48565
424	N/A	45818
446	09256	09244
N/A = Not for Sale		

Model No.	A2681	A2682
461	09246	09246
463	49881	49881
465	07832	07832
532	06050	06050
550	45346	45346
553	45345	45345
561	07524	07524
564	07523	07523
570	42606	42606
572	06044	06044
606	07521	07521
626	07497	07497
724	06635	06635
738	06166	06166
781	07121	07121



LIQUID CONTROLS GROUP



Алматы (7273)495-231
Ангарск (3955)60-70-56
Архангельск (8182)63-90-72
Астрахань (8512)99-46-04
Барнаул (3852)73-04-60
Белгород (4722)40-23-64
Благовещенск (4162)22-76-07
Брянск (4832)59-03-52
Владивосток (423)249-28-31
Владикавказ (8672)28-90-48
Владимир (4922)49-43-18
Волгоград (844)278-03-48
Вологда (8172)26-41-59
Воронеж (473)204-51-73
Екатеринбург (343)384-55-89
Иваново (4932)77-34-06

Ижевск (3412)26-03-58
Иркутск (395)279-98-46
Казань (843)206-01-48
Калининград (4012)72-03-81
Калуга (4842)92-23-67
Кемерово (3842)65-04-62
Киров (8332)68-02-04
Коломна (4966)23-41-49
Кострома (4942)77-07-48
Краснодар (861)203-40-90
Красноярск (391)204-63-61
Курган (3522)50-90-47
Курск (4712)77-13-04
Липецк (4742)52-20-81
Магнитогорск (3519)55-03-13

Россия +7(495)268-04-70

Москва (495)268-04-70
Мурманск (8152)59-64-93
Набережные Челны (8552)20-53-41
Нижегород (831)429-08-12
Новокузнецк (3843)20-46-81
Новосибирск (383)227-86-73
Ноябрьск (3496)41-32-12
Омск (3812)21-46-40
Орел (4862)44-53-42
Оренбург (3532)37-68-04
Пенза (8412)22-31-16
Пермь (342)205-81-47
Петрозаводск (8142)55-98-37
Псков (8112)59-10-37

Казахстан +7(7172)727-132

Ростов-на-Дону (863)308-18-15
Рязань (4912)46-61-64
Самара (846)206-03-16
Санкт-Петербург (812)309-46-40
Саранск (8342)22-96-24
Саратов (845)249-38-78
Севастополь (8692)22-31-93
Симферополь (3652)67-13-56
Смоленск (4812)29-41-54
Сочи (862)225-72-31
Ставрополь (8652)20-65-13
Сургут (3462)77-98-35
Сыктывкар (8212)25-95-17
Тамбов (4752)50-40-97

Киргизия +996(312)96-26-47

Тверь (4822)63-31-35
Тольятти (8482)63-91-07
Томск (3822)98-41-53
Тула (4872)33-79-87
Тюмень (3452)66-21-18
Улан-Удэ (3012)59-97-51
Ульяновск (8422)24-23-59
Уфа (347)229-48-12
Хабаровск (4212)92-98-04
Чебоксары (8352)28-53-07
Челябинск (351)202-03-61
Череповец (8202)49-02-64
Чита (3022)38-34-83
Якутск (4112)23-90-97
Ярославль (4852)69-52-93